

# CR, CRI, CRN

Vertical, multistage centrifugal pumps  
50 Hz



be  
think  
innovate

**GRUNDFOS** 

<b>1. Introduction</b>	<b>4</b>
Performance range	5
Applications	7
Product range	8
Pump	10
Motor	10
Terminal box positions	11
Ambient temperature	11
Viscosity	11
<b>2. Construction</b>	<b>12</b>
CR 1s, 1, 3, 5, 10, 15 and 20	12
CRI 1s, 1, 3, 5, 10, 15 and 20	13
CRN 1s, 1, 3, 5, 10, 15 and 20	14
CR 32, 45 and 64	15
CRN 32, 45 and 64	16
CR 95, 125, 155, 185, 215	17
CRN 95, 125, 155, 185, 215	18
Type key	19
<b>3. Operating conditions</b>	<b>20</b>
Maximum operating pressure and liquid temperature	20
Maximum inlet pressure	22
<b>4. Selection</b>	<b>23</b>
Selection of pumps	23
How to read the curve charts	27
Guidelines to performance curves	27
<b>5. Performance curves and technical data</b>	<b>28</b>
CR 1s	28
CRI, CRN 1s	30
CR 1	32
CRI, CRN 1	34
CR 3	36
CRI, CRN 3	38
CR 5	40
CRI, CRN 5	42
CR 10	44
CRI, CRN 10	46
CR 15	48
CRI, CRN 15	50
CR 20	52
CRI, CRN 20	54
CR 32	56
CRN 32	58
CR 45	60
CRN 45	62
CR 64	64
CRN 64	66
CR 95	68
CRN 95	70
CR 125	72
CRN 125	74
CR 155	76
CRN 155	78
CR 185	80
CRN 185	82
CR 215	84
CRN 215	86
<b>6. Motor data</b>	<b>88</b>
Standard motors for CR, CRI, CRN, 50 Hz	88

<b>7. List of pumped liquids</b>	<b>89</b>
<b>8. Accessories</b>	<b>91</b>
Pipe connection .....	91
LiqTec .....	100
Sensors .....	101
<b>9. Variants</b>	<b>102</b>
<b>10. Grundfos Product Center</b>	<b>103</b>

## 1. Introduction

This data booklet deals with Grundfos CR, CRI and CRN pumps.



Fig. 1 CR, CRI and CRN 1s-64

GR5381



Fig. 2 CR, CRN 95-215

TM06 9062 1617

CR, CRI and CRN pumps are vertical multistage, centrifugal pumps. The in-line design of the pumps enables installation in a horizontal one-pipe system where the inlet and outlet ports are in the same horizontal level and have the same pipe dimensions. This design provides a more compact pump design. CR pumps are available in various sizes and various numbers of stages to deliver the flow rate and pressure required.

CR pumps are designed for a variety of applications ranging from the pumping of potable water to the pumping of chemicals. The pumps are therefore suitable for a wide diversity of pumping systems where the performance and material of the pump meet specific demands.

A CR pump consists of two main components: the motor and the pump unit.

The motor is a Grundfos or Siemens motor designed to EN standards.

The pump unit consists of optimised hydraulics, various types of connections, a sleeve, a pump head and various other parts. See section 2. *Construction*.

CR pumps are available in various material versions according to the pumped liquid.

### Typical applications

CR, CRI and CRN pumps are designed to cover a wide variety of applications such as the following:

- water supply
- cooling
- heating
- pressure boosting
- water treatment
- liquid transfer of cold or hot clean liquids.

For more details, see *Applications* on page 7.

### Pumped liquids

CR, CRI and CRN pumps are suitable for pumping liquids which are thin, clean, non-flammable, non-combustible or non-explosive liquids, not containing solid particles or fibres.

When pumping liquids with a density and/or viscosity higher than that of water, use motors with correspondingly higher outputs, if required.

Whether a pump is suitable for a particular liquid depends on a number of factors of which the most important are chloride content, pH value, temperature, content of chemicals and oils. Please consult Grundfos for information about which pump types are suitable for a specific liquid.

See also 7. *List of pumped liquids*.

### CR and CRI

CR and CRI pumps are suitable for non-corrosive liquids.

Use CR or CRI pumps for liquid transfer, circulation and pressure boosting of cold or hot clean water.

### CRN

CRN pumps are suitable for industrial liquids.

Use CRN pumps in systems where all parts in contact with the liquid must be made of high-grade stainless steel.

### CRT

For saline or chloride-containing liquids such as sea water or for oxidising agents such as hypochlorites, we offer CRT pumps made of titanium.

- See the separate data booklet on CRT, CRTE available on Grundfos Product Center (<http://product-selection.grundfos.com/>).

Performance range

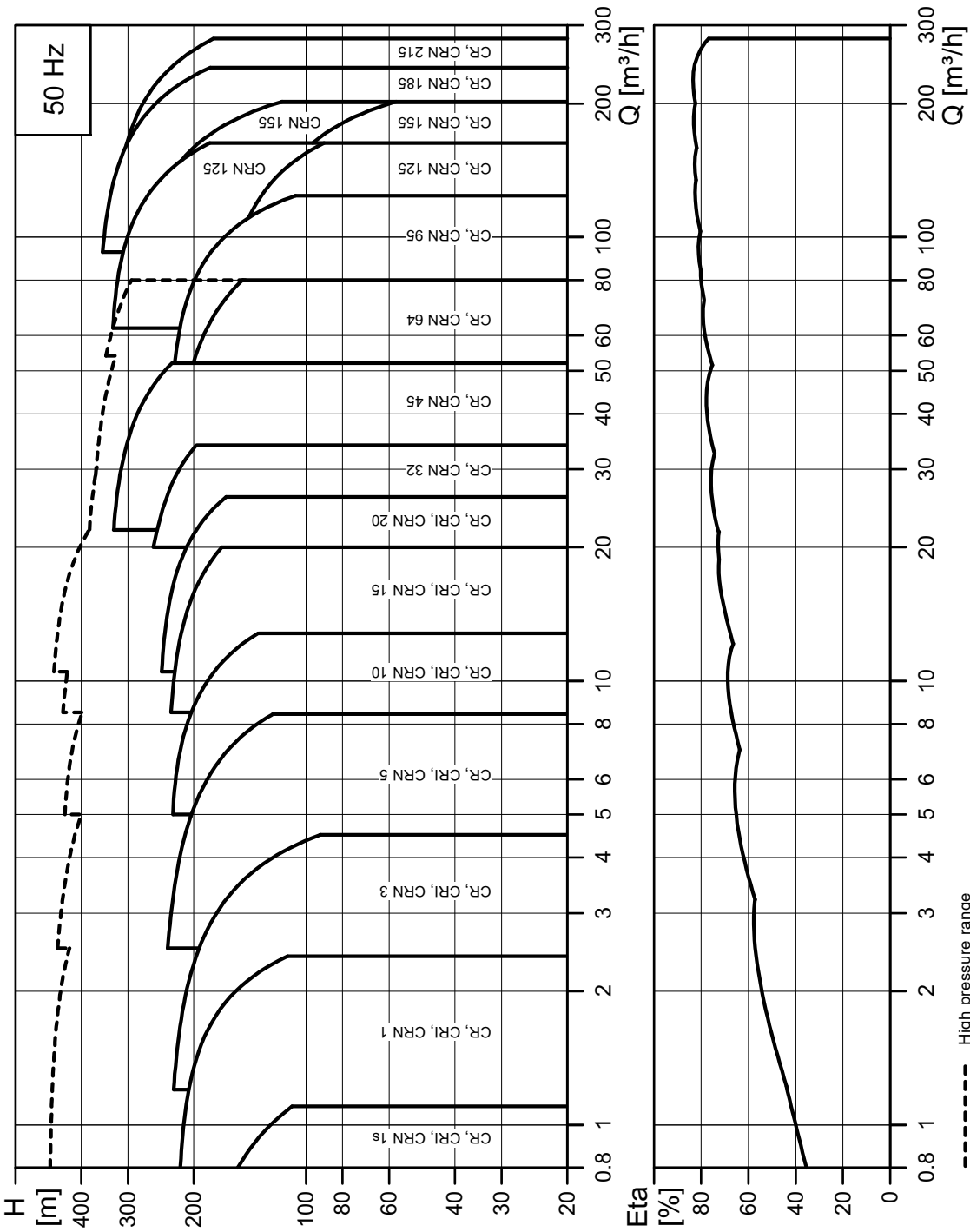

Fig. 3 Performance range, CR, CRN

TM02 1192 0721

## EuP compliant

The CR, CRI and CRN pumps are energy-optimised and comply with the EuP Directive (Commission Regulation (EC) No 547/2012) which has been effective since 1 January 2013. As from this date, all pumps will be classified and graduated in a new energy minimum efficiency index (MEI).

## Minimum efficiency index

Minimum efficiency index (MEI) means the dimensionless scale unit for hydraulic pump efficiency at best efficiency point (BEP), part load (PL) and overload (OL). The Commission Regulation (EU) sets efficiency requirements to  $MEI \geq 0.10$  as from 1 January 2013 and  $MEI \geq 0.40$  as from 1 January 2015. An indicative benchmark for best-performing water pump available on the market as from 1 January 2013 is determined in the Regulation.

- The benchmark for most efficient water pumps is  $MEI \geq 0.70$ .
- The efficiency of a pump with a trimmed impeller is usually lower than that of a pump with the full impeller diameter. The trimming of the impeller will adapt the pump to a fixed duty point, leading to reduced energy consumption. The minimum efficiency index (MEI) is based on the full impeller diameter.
- The operation of this water pump with variable duty points may be more efficient and economic when controlled, for example, by the use of a variable-speed drive that matches the pump duty to the system.
- Information on benchmark efficiency is available at <http://europump.eu/efficiencycharts>.

## Minimum efficiency index (MEI)

Pump type	MEI
CR 1s-3	0.54
CR 1-3	$\geq 0.70$
CR 3-3	$\geq 0.70$
CR 5-3	0.57
CR 10-3	$\geq 0.70$
CR 15-3	$\geq 0.70$
CR 20-3	$\geq 0.70$
CR 32-3	$\geq 0.70$
CR 45-3	$\geq 0.70$
CR 64-3	$\geq 0.70$
CR 95-3	$\geq 0.70$
CR 125-3	$\geq 0.70$
CR 155-3	$\geq 0.70$
CR 185-3	$\geq 0.70$
CR 215-3	$\geq 0.70$

## Applications

Application	CR, CRI	CRN
<b>Water supply</b>		
Filtration and transfer at waterworks	•	○
Distribution from waterworks	•	○
Pressure boosting in mains	•	○
Pressure boosting in, for example, high-rise buildings, hotels	•	○
Pressure boosting for industrial water supply	•	○
<b>Industry</b>		
<b>Pressure boosting</b>		
Process-water systems	•	•
Washing and cleaning systems	•	•
Vehicle-washing tunnels	•	○
Firefighting systems	•	-
<b>Liquid transfer</b>		
Cooling and air-conditioning systems (refrigerants)	•	○
Boiler feed and condensate systems	•	○
Machine tools (cooling lubricants)	•	•
Aquafarming	•	○
<b>Special transfer duties</b>		
Oils and alcohols	•	•
Acids and alkalis	-	•
Glycol and coolants	•	-
<b>Water treatment</b>		
Ultra-filtration systems	-	•
Reverse osmosis systems	-	•
Softening, ionising, demineralising systems	-	•
Distillation systems	-	•
Separators	•	•
Swimming baths	-	•
<b>Irrigation</b>		
Field irrigation (flooding)	•	○
Sprinkler irrigation	•	○
Drip-feed irrigation	•	○

- Recommended version.
- Alternative version.

Note that for applications involving CIP (clean-in-place) and CR, CRN 95-255 pumps with motors above 55 kW, you must use a bearing flange and a base without thrust handling device.

## Product range

Range	CR 1s	CR 1	CR 3	CR 5	CR 10	CR 15	CR 20
Rated flow rate [m <sup>3</sup> /h]	0.8	1	3	5	10	15	20
Liquid temperature [°C]	-20 to +120						
Liquid temperature [°C], on request	-40 to +180						
Maximum pump efficiency [%]	35	48	58	66	70	72	72
<b>CR pumps</b>							
Flow rate [m <sup>3</sup> /h]	0.3 - 1.1	0.7 - 2.4	1.2 - 4.5	2.5 - 8.5	5-13	9-24	11-29
Maximum pressure [bar]	21	22	24	24	22	23	25
High pressure [bar], on request (CRN)	-	47	41	47	44	47	48
Motor power [kW]	0.37 - 1.1	0.37 - 2.2	0.37 - 3	0.37 - 5.5	0.37 - 7.5	1.1 - 15	1.1 - 18.5
<b>Version</b>							
CR: Cast iron and stainless steel EN 10088 1.4301 ≈ AISI 304	•	•	•	•	•	•	•
CRI: Stainless steel EN 10088 1.4301 ≈ AISI 304	•	•	•	•	•	•	•
CRN: Stainless steel EN 10088 1.4401 ≈ AISI 316	•	•	•	•	•	•	•
CRT: Titanium	See the CRT, CRTE data booklet available on Grundfos Product Center > <a href="http://product-selection.grundfos.com/">http://product-selection.grundfos.com/</a> .						
<b>CR pipe connection</b>							
Oval flange (BSP)	Rp 1	Rp 1	Rp 1	Rp 1 1/4	Rp 1 1/4	Rp 2	Rp 2
Oval flange (BSP), on request	Rp 1 1/4	Rp 1 1/4	Rp 1 1/4	Rp 1	Rp 1 1/4 Rp 2	Rp 2 1/2	Rp 2 1/2
Flange	DN 25/ DN 32	DN 25/ DN 32	DN 25/ DN 32	DN 25/ DN 32	DN 40	DN 50	DN 50
Flange, on request	-	-	-	-	DN 50	-	-
<b>CRI pipe connection</b>							
Oval flange (BSP)	Rp 1	Rp 1	Rp 1 1/4	Rp 1 1/4	Rp 1 1/2	Rp 2	Rp 2
Oval flange (BSP), on request	Rp 1 1/4	Rp 1 1/4	Rp 1	Rp 1	Rp 2	-	-
Flange	DN 25/ DN 32	DN 25/ DN 32	DN 25/ DN 32	DN 25/ DN 32	DN 40	DN 50	DN 50
Flange, on request	-	-	-	-	DN 50	-	-
PJE coupling (Victaulic type)	R 1 1/4 DN 32	R 1 1/4 DN 32	R 1 1/4 DN 32	R 1 1/4 DN 32	R 2 DN 50	R 2 DN 50	R 2 DN 50
Clamp coupling (L-coupling)	∅48.3	∅48.3	∅48.3	∅48.3	∅60.3	∅60.3	∅60.3
Union (+GF+)	G 2	G 2	G 2	G 2	G 2 3/4	G 2 3/4	G 2 3/4
<b>CRN pipe connection</b>							
Oval flange (BSP)	Rp 1	Rp 1	Rp 1 1/4	Rp 1 1/4	Rp 1 1/2	Rp 2	Rp 2
Oval flange (BSP), on request	Rp 1 1/4	Rp 1 1/4	Rp 1	Rp 1	Rp 2	-	-
Flange	DN 25/ DN 32	DN 25/ DN 32	DN 25/ DN 32	DN 25/ DN 32	DN 40	DN 50	DN 50
Flange, on request	-	-	-	-	DN 50	-	-
PJE coupling (Victaulic type)	R 1 1/4 DN 32	R 1 1/4 DN 32	R 1 1/4 DN 32	R 1 1/4 DN 32	R 2 DN 50	R 2 DN 50	R 2 DN 50
Clamp coupling (L-coupling)	∅42.2	∅42.2	∅42.2	∅42.2	∅60.3	∅60.3	∅60.3
Union (+GF+)	G 2	G 2	G 2	G 2	G 2 3/4	G 2 3/4	G 2 3/4

- Standard.
- Available.

Range	CR 32	CR 45	CR 64	CR 95	CR 125	CR 155	CR 185	CR 215
Rated flow rate [m <sup>3</sup> /h]	32	45	64	95	125	155	185	215
Liquid temperature [°C]	-30 to +120			-20 to +120				
Liquid temperature [°C], on request	-40 to +180						-40	
Maximum pump efficiency [%]	78	79	80	81	82	82	82	84
<b>CR pumps</b>								
Flow rate [m <sup>3</sup> /h]	15-40	22-58	30-85	45-120	60-160	75-200	92-240	108-280
Maximum pressure [bar]	28	33	22	23	32 <sup>1)</sup>	27 <sup>1)</sup>	35	34
High pressure [bar], on request (CRN)	50	49	41	-	-	-	-	-
Motor power [kW]	1.5 - 30	3-45	4-45	5.5 - 55	11-110	11-110	18.5-200	22-200
<b>Version</b>								
CR: Cast iron and stainless steel EN 10088 1.4301 ≈ AISI 304	•	•	•	•	•	•	•	•
CRI: Stainless steel EN 10088 1.4301 ≈ AISI 304	-	-	-	-	-	-	-	-
CRN: Stainless steel EN 10088 1.4401 ≈ AISI 316	•	•	•	•	•	•	•	•
CRT: Titanium	See the CRT, CRTE data booklet available on Grundfos Product Center > <a href="http://product-selection.grundfos.com/">http://product-selection.grundfos.com/</a> .							
<b>CR pipe connection</b>								
Oval flange (BSP)	-	-	-	-	-	-	-	-
Oval flange (BSP), on request	-	-	-	-	-	-	-	-
Flange	DN 65	DN 80	DN 100	DN 100	DN 150	DN 150	DN 200	DN 200
Flange, on request	DN 80	DN 100	DN 125	-	-	-	-	-
<b>CRN pipe connection</b>								
Oval flange (BSP)	-	-	-	-	-	-	-	-
Oval flange (BSP), on request	-	-	-	-	-	-	-	-
Flange	DN 65	DN 80	DN 100	DN 100	DN 150	DN 150	DN 200	DN 200
Flange, on request	DN 80	DN 100	DN 125	-	-	-	-	-
PJE coupling (Victaulic type)	3"	4"	4"	4"	6"	6"	8"	8"
Clamp coupling (L-coupling)	88.9	114.3	114.3	114.3	168.3	168.3	219.1	219.1
Union (+GF+)	-	-	-	-	-	-	-	-

- Standard.
- Available.

<sup>1)</sup> CR pumps: Maximum operating pressure is 25 bar.

## Pump

The CR pumps are non-self-priming, vertical multistage centrifugal pumps.

The pumps are available with a Grundfos or Siemens standard motor.

The pump consists of a base and a pump head. The chamber stack and the sleeve are secured between the base and the pump head by means of staybolts. The base has inlet and outlet ports on the same level (in line). All pumps are fitted with a maintenance-free mechanical shaft seal of the cartridge type.

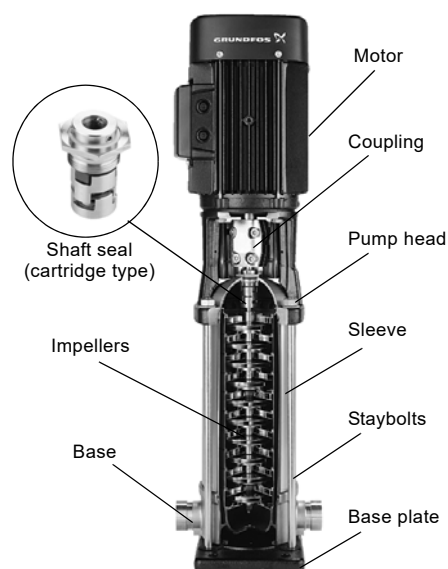

Fig. 4 CR pump

GR5357 - GR3395

## Motor

### Grundfos MG standard and Siemens motors

CR, CRI and CRN pumps are fitted with totally enclosed, fan-cooled, 2-pole standard motors with principal dimensions to EN standards.

Electrical tolerances according to EN 60034.

CR, CRI, CRN pumps are fitted with three-phase MG motors as standard up to 22 kW and Siemens motors from 30 to 200 kW.

CR, CRI, CRN pumps from 0.37 to 2.2 kW are also available with single-phase motors (1 x 220-230/240 V). See Grundfos Product Center (<http://product-selection.grundfos.com/>).

## Grundfos E-motors

We also offer frequency-controlled CRE, CRIE and CRNE pumps which are the ideal choice for a number of applications characterised by a demand for variable flow rate at constant pressure. These pumps are suited for water supply systems and pressure boosting as well as for industrial applications. Depending on the application, the pumps offer energy savings, increased comfort and improved processing.

See the CRE, CRIE and CRNE data booklet available on Grundfos Product Center (<http://product-selection.grundfos.com/>).

### Electrical data

MG motor CR, CRI, CRN	
Mounting designation	Up to 4 kW: V18 From 5.5 kW: V1
Insulation class	F
Efficiency class	IE3
Enclosure class	IP55 <sup>1)</sup>
Supply voltage	P2: 0.37 - 1.5 kW: 3 x 220-240/380-415 V
Tolerance: - 10 %/+ 10 %	P2: 2.2 - 5.5 kW: 3 x 380-415 V
	P2: 7.5 - 22 kW: 3 x 380-415/660-690 V
	P2: 30 - 200 kW: 3 x 380-420/660-725 V
Supply frequency	50 Hz

<sup>1)</sup> IP44 and IP54 are available on request.

### Optional motors

The Grundfos standard range of motors covers a wide variety of application demands. However, for special applications or operating conditions, custom-built motor solutions can be provided.

For special applications or operating conditions, we offer custom-built motors such as the following:

- ATEX-approved motors
- MG motors with anti-condensation heating unit
- motors with thermal protection.

### Motor protection

#### MG and Siemens motors

Single-phase Grundfos motors have a built-in thermal overload switch (TP 211 according to IEC 34-11).

Three-phase motors must be connected to a motor-protective circuit breaker according to local regulations.

Three-phase Grundfos motors as from 3 kW have a built-in thermistor (PTC) according to DIN 44082 (TP 211 according to IEC 34-11).

## Terminal box positions

As standard, the terminal box is fitted on the inlet side of the pump.

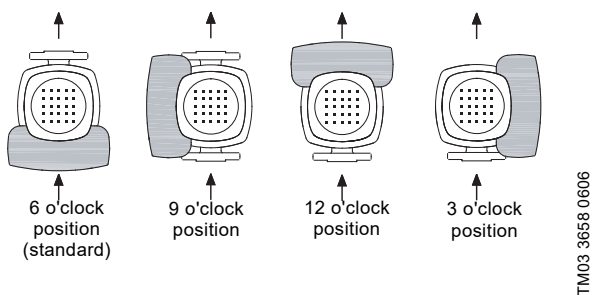

Fig. 5 Terminal box positions

TM03 3658 0606

## Viscosity

Pumping liquids with densities or kinematic viscosities higher than those of water will cause a considerable pressure drop, a drop in the hydraulic performance and a rise in the power consumption.

In such situations, the pump must be fitted with a larger motor. If in doubt, contact Grundfos.

## Ambient temperature

Motor power [kW]	Motor make	Motor efficiency class	Maximum ambient temperature [°C]	Maximum altitude above sea level [m]
0.37 - 0.55	MG	-	40	1000
0.75 - 22	MG	IE3	60	3500
30-200	Siemens	IE3	55	2750

If the ambient temperature exceeds the above maximum temperatures or the pump is installed at an altitude exceeding the above altitude values, the motor must not be fully loaded due to the risk of overheating. Overheating may result from excessive ambient temperatures or the low density and consequently low cooling effect of the air.

In such cases, it may be necessary to use a motor with a higher rated output.

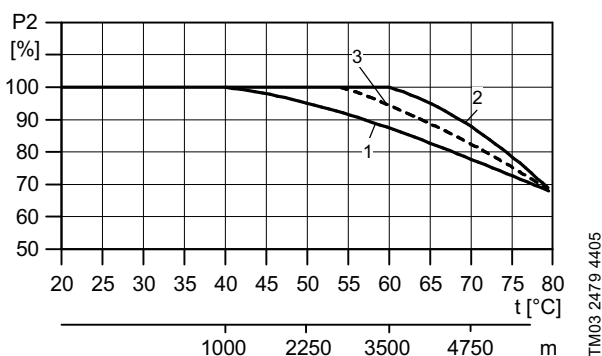

Fig. 6 Motor output in relation to temperature/altitude

TM03 2479 4405

Pos.	Motor power [kW]	Motor make
1	0.37 and 0.55	MG
2	0.75 - 22	MG
3	30-200	Siemens

## 2. Construction

### CR 1s, 1, 3, 5, 10, 15 and 20



TM02 1198 0601 - GR7377 - GR7379

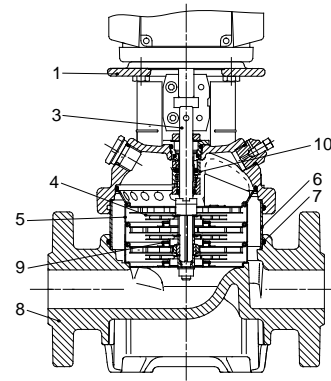

TM02 1194 1403

#### Materials, CR

Pos.	Designation	Materials	DIN/EN	≈ AISI/ASTM
1	Pump head	Grey cast iron	EN 1561 EN-GJL-200	ASTM 25B
3	Shaft	Stainless steel	EN 10088 1.4401 <sup>1)</sup> EN 10088 1.4057 <sup>2)</sup>	AISI 316 <sup>1)</sup> AISI 431 <sup>2)</sup>
4	Impeller	Stainless steel	EN 10088 1.4301	AISI 304
5	Chamber	Stainless steel	EN 10088 1.4301	AISI 304
6	Sleeve	Stainless steel	EN 10088 1.4301	AISI 304
7	O-ring for sleeve	EPDM or FKM	-	-
8	Base	Grey cast iron	EN 1561 EN-GJL-250	ASTM 25B
9	Neck ring	PTFE	-	-
10	Shaft seal (seal faces)	Silicon carbide/Silicon carbide	-	-
	Staybolts	Bright steel	EN 10277-2 1.0533	-

<sup>1)</sup> CR 1s, 1, 3, 5.

<sup>2)</sup> CR 10, 15, 20.

## CRI 1s, 1, 3, 5, 10, 15 and 20



TM02 1808 2001 - GR7375

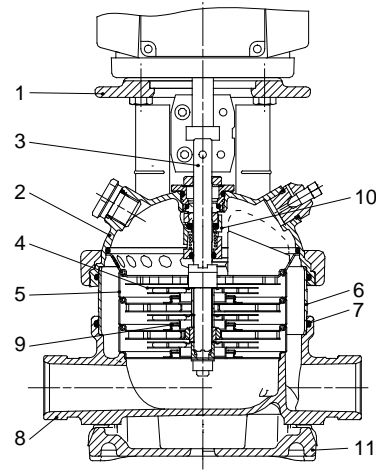

TM02 1195 1403

## Materials, CRI

Pos.	Designation	Materials	DIN/EN	≈ AISI/ASTM
1	Motor stool	Grey cast iron <sup>1)</sup>	EN 1563 EN-GJS-450-10	ASTM A536 65-45-12
2	Pump head	Stainless steel	EN 10283 1.4408	CF 8M equal to AISI 316
3	Shaft	Stainless steel	EN 10088 1.4401 <sup>2)</sup> EN 10088 1.4057 <sup>3)</sup>	AISI 316 <sup>2)</sup> AISI 431 <sup>3)</sup>
4	Impeller	Stainless steel	EN 10088 1.4301	AISI 304
5	Chamber	Stainless steel	EN 10088 1.4301	AISI 304
6	Sleeve	Stainless steel	EN 10088 1.4301	AISI 304
7	O-ring for sleeve	EPDM or FKM	-	-
8	Base	Stainless steel	EN 10283 1.4408	CF 8M equal to AISI 316
9	Neck ring	PTFE	-	-
10	Shaft seal (seal faces)	Silicon carbide/Silicon carbide	-	-
11	Base plate	Grey cast iron <sup>1)</sup>	EN 1561 EN-GJL-200 <sup>3)</sup> + 4) EN 1563 EN-GJS-500-7 <sup>5)</sup>	ASTM 25B <sup>3)</sup> + 4) ASTM A536 65-45-12 <sup>5)</sup>
	Staybolts	Bright steel	EN 10277-2 1.0533	-

<sup>1)</sup> Stainless steel available on request.

<sup>2)</sup> CRI, 1s, 1, 3, 5.

<sup>3)</sup> CRI, 10, 15, 20.

<sup>4)</sup> CRI 1s, 1, 3, 5 with FGJ flange connection.

<sup>5)</sup> CRI 1s, 1, 3, 5 with clamp connections (such as PJE, CA).

## CRN 1s, 1, 3, 5, 10, 15 and 20



TM02 1808 2001 - GR7373

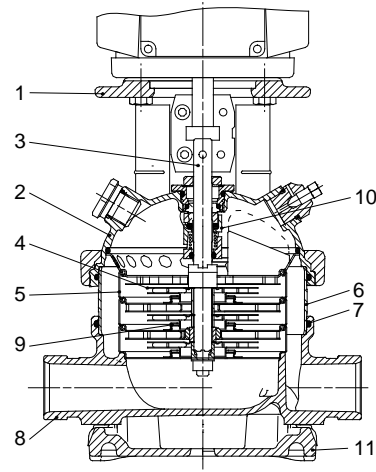

TM02 1195 1403

## Materials, CRN

Pos.	Designation	Materials	DIN/EN	≈ AISI/ASTM
1	Motor stool	Grey cast iron <sup>1)</sup>	EN 1563 EN-GJS-450-10	ASTM A536 65-45-12
2	Pump head	Stainless steel	EN 10283 1.4408	CF 8M equal to AISI 316
3	Shaft	Stainless steel	EN 10088 1.4401 <sup>2)</sup> EN 10088 1.4460 <sup>3)</sup>	AISI 316 <sup>2)</sup> AISI 329 <sup>3)</sup>
4	Impeller	Stainless steel	EN 10088 1.4401	AISI 316
5	Chamber	Stainless steel	EN 10088 1.4401	AISI 316
6	Sleeve	Stainless steel	EN 10088 1.4401	AISI 316
7	O-ring for sleeve	EPDM or FKM	-	-
8	Base	Stainless steel	EN 10283 1.4408	CF 8M equal to AISI 316
9	Neck ring	PTFE	-	-
10	Shaft seal (seal faces)	Silicon carbide/Silicon carbide	-	-
11	Base plate	Grey cast iron <sup>1)</sup>	EN 1561 EN-GJL-200 <sup>3)</sup> + 4) EN 1563 EN-GJS-500-7 <sup>5)</sup>	ASTM 25B <sup>3)</sup> + 4) ASTM A536 65-45-12 <sup>5)</sup>
	Staybolts	Stainless steel	EN 10088 1.4401 <sup>2)</sup> EN 10088 1.4057 <sup>3)</sup>	AISI 316 <sup>2)</sup> AISI 431 <sup>3)</sup>

1) Stainless steel available on request.

2) CRN 1s, 1, 3, 5.

3) CRN 10, 15, 20.

4) CRN 1s, 1, 3, 5 with FGJ flange connection.

5) CRN 1s, 1, 3, 5 with clamp connections (such as PJE, CA).

## CR 32, 45 and 64



TM01 2150 1298

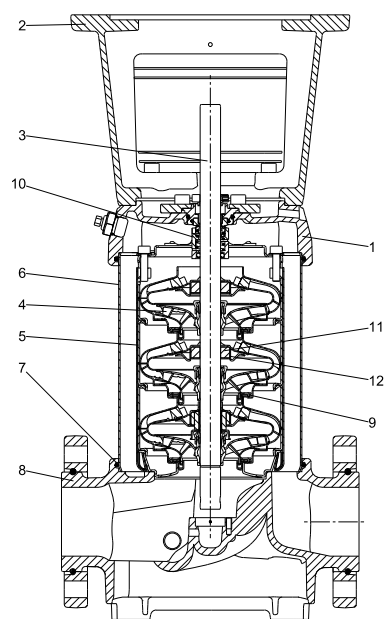

TM06 0711 0814

## Materials, CR

Pos.	Designation	Materials	DIN/EN	≈ AISI/ASTM
1	Pump head	Ductile cast iron	EN 1563 EN-GJS-500-7	ASTM A536 65-45-12
2	Motor stool	Grey cast iron	EN 1561 EN-GJL-200	ASTM 25B
3	Shaft	Stainless steel	EN 10088 1.4057	AISI 431
4	Impeller	Stainless steel	EN 10088 1.4301	AISI 304
5	Chamber	Stainless steel	EN 10088 1.4301	AISI 304
6	Sleeve	Stainless steel	EN 10088 1.4301	AISI 304
7	O-ring for sleeve	EPDM or FKM	-	-
8	Base	Ductile cast iron	EN 1563 EN-GJS-500-7	ASTM A536 65-45-12
9	Neck ring	Carbon-graphite-filled PTFE	-	-
10	Shaft seal (seal faces)	Silicon carbide/Silicon carbide	-	-
11	Bearing ring	Silicon carbide/Silicon carbide	-	-
12	Support bearing	Carbon-graphite-filled PTFE	-	-
13	Base plate	Ductile cast iron	EN 1563 EN-GJS-500-7	ASTM A536 65-45-12
	Staybolts	Bright steel	EN 10277-2 1.0533	-

## CRN 32, 45 and 64



TM06 9503 2417

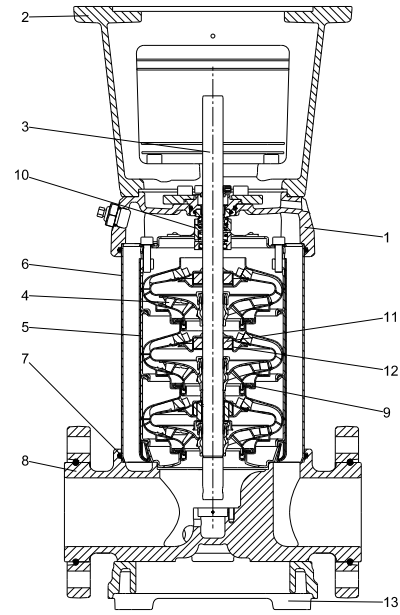

TM06 0712 0814

## Materials, CRN

Pos.	Designation	Materials	DIN/EN	≈ AISI/ASTM
1	Pump head	Stainless steel	EN 10283 1.4408	CF 8M equal to AISI 316
2	Motor stool	Grey cast iron <sup>1)</sup>	EN 1561 EN-GJL-200	ASTM 25B
3	Shaft	Stainless steel	EN 10088 1.4462	-
4	Impeller	Stainless steel	EN 10088 1.4401	AISI 316
5	Chamber	Stainless steel	EN 10088 1.4401	AISI 316
6	Sleeve	Stainless steel	EN 10088 1.4401	AISI 316
7	O-ring for sleeve	EPDM or FKM	-	-
8	Base	Stainless steel	EN 10283 1.4408	CF 8M equal to AISI 316
9	Neck ring	Carbon-graphite-filled PTFE	-	-
10	Shaft seal (seal faces)	Silicon carbide/Silicon carbide	-	-
11	Bearing ring	Silicon carbide/Silicon carbide	-	-
12	Support bearing	Carbon-graphite-filled PTFE	-	-
13	Base plate	Ductile cast iron <sup>1)</sup>	EN 1563 EN-GJS-500-7	ASTM A536 65-45-12
	Staybolts	Stainless steel	EN 10088 1.4057	AISI 431

<sup>1)</sup> Stainless steel available on request.

## CR 95, 125, 155, 185, 215



DIN flange

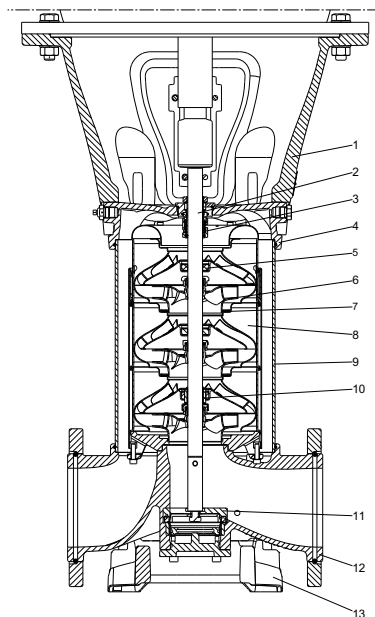

TM06 9206 1917

TM06 5161 1917

## Materials, CR

Pos.	Designation	Materials	DIN/EN	≈ AISI/ASTM
1	Motor stool	Ductile cast iron	EN 1563 EN-GJS-500-7	ASTM A536-84 65-45-12
2	Shaft	Stainless steel	EN 10088 1.4057 <sup>1)</sup> EN 10088 1.4462 <sup>2)</sup>	AISI 431 <sup>1)</sup> AISI 318 LN <sup>2)</sup>
3	Shaft seal (seal faces)	Silicon carbide/Silicon carbide	-	-
4	Pump head	Ductile cast iron	EN 1563 EN-GJS-500-7	ASTM A536-84 65-45-12
5	Support bearing (bush)	Carbon-graphite-filled PTFE	-	-
6	Impeller	Stainless steel	EN 10088 1.4301 EN 10088 1.4401 <sup>3)</sup>	AISI 304 AISI 316 <sup>3)</sup>
7	Neck ring	PEEK	-	-
8	Chamber	Stainless steel	EN 10088 1.4301 EN 10088 1.4401 <sup>3)</sup>	AISI 304 AISI 316 <sup>3)</sup>
9	Sleeve	Stainless steel	EN 10088 1.4301 <sup>1)</sup> EN 10088 1.4404 <sup>2)</sup>	AISI 304 <sup>1)</sup> AISI 316 L <sup>2)</sup>
10	Bearing ring	Tungsten carbide/Tungsten carbide	-	-
11	Thrust handling device <sup>4)</sup>	Stainless steel	EN 10088 1.4401 EN 10283 1.4408	AISI 316 CF 8M equal to AISI 316
		Silicon carbide/Tungsten carbide	-	-
12	Base	Ductile cast iron	EN 1563 EN-GJS-500-7	ASTM A536-84 65-45-12
13	Base plate	Ductile cast iron	EN 1563 EN-GJS-500-7	ASTM A536-84 65-45-12
	Staybolts	Stainless steel	EN 10088 1.4057	AISI 431

1) CR 95.

2) CR 125, 155, 185, 215.

3) CR 185, 215.

4) Only fitted on pumps with 75 kW motors or larger.

## CRN 95, 125, 155, 185, 215



Collar flange

DIN flange

Victaulic type (PJE)

TM06 9203 1917 - TM06 9208 1917 - TM06 9210 1917

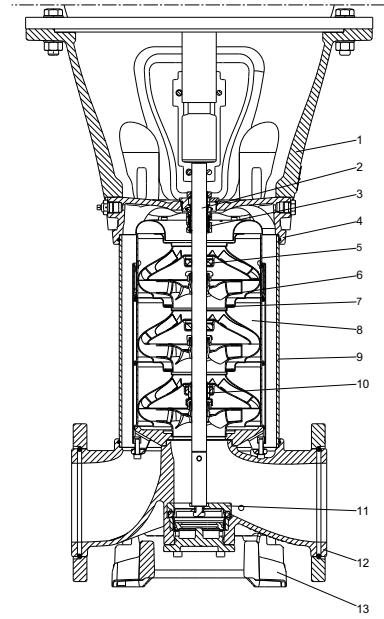

TM06 5161 1917

## Materials, CRN

Pos.	Designation	Materials	DIN/EN	≈ AISI/ASTM
1	Motor stool	Ductile cast iron	EN 1563 EN-GJS-500-7	ASTM A536-84 65-45-12
2	Shaft	Stainless steel	EN 10088 1.4462	318 LN
3	Shaft seal (seal faces)	Silicon carbide/Silicon carbide	-	-
4	Pump head	Stainless steel	EN 10283 1.4408	CF 8M
5	Support bearing (bush)	Carbon-graphite-filled PTFE	-	-
6	Impeller	Stainless steel	EN 10088 1.4401	AISI 316
7	Neck ring	PEEK	-	-
8	Chamber	Stainless steel	EN 10088 1.4401	AISI 316
9	Sleeve	Stainless steel	EN 10088 1.4404	AISI 316 L
10	Bearing ring	Tungsten carbide/Tungsten carbide	-	-
11	Thrust handling device <sup>1)</sup>	Stainless steel	EN 10088 1.4401	AISI 316
		Silicon carbide/Tungsten carbide	EN 10283 1.4408	CF 8M equal to AISI 316
12	Base	Stainless steel	EN 10283 1.4408	CF 8M
13	Base plate	Ductile cast iron	EN 1563 EN-GJS-500-7	ASTM A536-84 65-45-12
		Staybolts	Stainless steel	EN 10088 1.4057

<sup>1)</sup> Only fitted on pumps with 75 kW motors or larger.

## Type key

Example	CR	E	32	s	-4	-2	-A	-F	-A	-E	-HQQE
Type range: CR, CRI, CRN, CRT											
Pump with integrated frequency converter											
Flow rate [m <sup>3</sup> /h]											
Undersize impeller (all impellers) CR 1s, CRI 1s, CRN 1s											
Number of impellers											
Number of reduced-diameter impellers CR, CRE, CRN, CRNE 32, 45, 64											
Code for pump version											
Code for pipe connection											
Code for materials											
Code for rubber parts											
Code for shaft seal											

### Key to codes

Code	Description
<b>Pump version</b>	
A	Basic version
B	Oversize motor
C	CR compact
D	Pump with pressure intensifier*
E	Pump with certificate
F	Pump for high temperatures (with air-cooled top)
G	E-pump without operating panel
H	Horizontal version
I	Different pressure rating
J	E-pump with a different maximum speed
K	Pump with low NPSH
L	Pump including Grundfos CUE and certificate
M	Magnetic drive
N	With sensor
O	Cleaned and dried
P	Undersize motor
Q	High-pressure pump with high-speed MGE motor*
R	Belt-driven pump
S	High-pressure pump
T	Thrust handling device*
U	ATEX approved pump
V	Cascade function
W	Deep-well pump with ejector*
X	Special version
Y	Electropolished
Z	Pumps with bearing flange
<b>Pipe connection</b>	
A	Oval flange
B	NPT thread
CA	FlexiClamp
CX	TriClamp*
F	DIN flange
FC	DIN 11853-2 flange (collar flange)
FE	EN 1092-1, type E
G	ANSI flange
J	JIS flange
N	Changed diameter of ports
P	PJE coupling (Victaulic type)
X	Special version

Code	Description
<b>Materials</b>	
A	Basic version
C	Carbon free pump
D	Carbon-graphite filled PTFE (bearings)/tungsten carbide
E	Pickled and passivated (Only Japan)
H	Flanges and base plate EN 1.4408
K	Bronze (bearings)/tungsten carbide
L	Motor stool, base plate and flanges EN 1.4408
M	Motor stool, base plate, coupling and flanges EN 1.4408 and coupling guards in cobber. Bolts, nuts and spacing pipes EN 1.4401 or higher grade
N	Flanges EN 1.4408
P	PEEK neck ring
Q	Silicon carbide/silicon carbide bearing in pump and Silicon carbide/silicon carbide seal faces in thrust handling device
R	Silicon carbide/silicon carbide bearing
S	PTFE neck rings
T	Base plate EN 1.4408
U	Silicon carbide/silicon carbide bearing in pump and Silicon carbide/tungsten carbide seal faces in thrust handling device
W	Tungsten carbide/tungsten carbide
X	Special version
<b>Code for rubber parts in pump</b>	
E	EPDM
F	FXM (Fluoraz <sup>®</sup> )
K	FFKM (Kalrez <sup>®</sup> )
N	CR (Neoprene)
V	FKM (Viton <sup>®</sup> )
<b>Shaft seal type designation</b>	
A	O-ring seal with fixed driver*
H	Balanced cartridge seal with O-ring
O	Double seal, back-to-back*
P	Double seal, tandem*
X	Special version*
<b>Seal face material</b>	
B	Carbon, synthetic resin-impregnated
U	Cemented tungsten carbide
Q	Silicon carbide
X	Other ceramics*
<b>Secondary seal material (rubber parts)</b>	
E	EPDM
F	FXM (Fluoraz <sup>®</sup> )
K	FFKM (Kalrez <sup>®</sup> )
V	FKM (Viton <sup>®</sup> )

\* Option. See the CR "Custom-built pumps" data booklet available on Grundfos Product Center. See QR code or link below.



<http://net.grundfos.com/qr/i/96486346>

Example	-H	-Q	-Q	-E
Shaft seal type designation				
Material of rotating seal face				
Material of stationary seal face				
Material of secondary seal (rubber parts)				

### 3. Operating conditions

#### Maximum operating pressure and liquid temperature

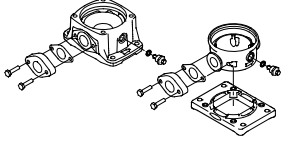
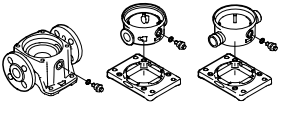
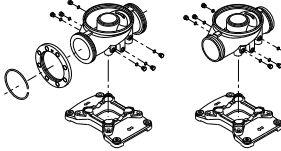
Pump type	Oval flange		PJE, clamp, union, DIN		DIN, PJE			
	Maximum permissible operating pressure [bar]	Liquid temperature [°C]	Maximum permissible operating pressure [bar]	Liquid temperature [°C]	Maximum permissible operating pressure [bar]	Liquid temperature [°C]		
	 TM02 1379 1101		 TM02 1383 1101		 TM06 9402 2417			
CR, CRI, CRN 1s	16	-20 to +120	25	-20 to +120	-	-		
CR, CRI, CRN 1	16		25		-	-		
CR, CRI, CRN 3	16		25		-	-		
CR, CRI, CRN 5	16		25		-	-		
CR, CRI 10-1 → 10-16	16		16		-	-		
CR, CRI 10-17 → 10-22	-		-		25	-	-	
CRN 10	-		-		25	-	-	
CR, CRI 15-1 → 15-7	10		-20 to +120		-	-	-	-
CR, CRI 15-1 → 15-10	-		-		16	-	-	-
CR, CRI 15-12 → 15-17	-		-		25	-20 to +120	-	-
CRN 15	-	-	25	-	-	-		
CR, CRI 20-1 → 20-7	10	-20 to +120	-	-	-	-		
CR, CRI 20-1 → 20-10	-	-	16	-	-	-		
CR, CRI 20-12 → 20-17	-	-	25	-20 to +120	-	-		
CRN 20	-	-	25	-	-	-		
CR, CRN 32-1-1 → 32-7	-	-	16	-30 to +120	-	-		
CR, CRN 32-8-2 → 32-14	-	-	30		-	-		
CR, CRN 45-1-1 → 45-5	-	-	16		-	-		
CR, CRN 45-6-2 → 45-11	-	-	30		-	-		
CR, CRN 45-12-2 → 45-13-2	-	-	33		-	-		
CR, CRN 64-1-1 → 64-5	-	-	16		-	-		
CR, CRN 64-6-2 → 64-8-1	-	-	30		-	-		
CR, CRN 95-1-1 → 95-5	-	-	-		-	16	-20 to +120*	
CR, CRN 95-6 → 95-8-2	-	-	-		-	25		
CR, CRN 125-1 → 125-4	-	-	-		-	16		
CR, CRN 125-5	-	-	-	-	25			
CRN 125-6 → 125-7	-	-	-	-	25			
CRN 125-8 → 125-10	-	-	-	-	40			
CR, CRN 155-1-1 → 155-4-1	-	-	-	-	16			
CRN 155-5-2 → 155-6	-	-	-	-	25			
CRN 155-7 → 155-8-2	-	-	-	-	40			
CR, CRN 185-1 → 185-3	-	-	-	-	16			
CR, CRN 185-4-3 → 185-5	-	-	-	-	25			
CR, CRN 185-6-3 → 185-8	-	-	-	-	40			
CR, CRN 215-1-1 → 215-3	-	-	-	-	16			
CR, CRN 215-4-2 → 215-5	-	-	-	-	25			
CR, CRN 215-6-3 → 215-7-2	-	-	-	-	40			

For pump sizes 32, 45, 64, the maximum pressure for PJE (Victaulic type) is 50 bar and only available in the CRN version.

\* For operating pressures above 30 bar, the temperature limits are -20 to +80 °C.

### Operating range of the shaft seal

All pumps will be delivered with an HQQE/V cartridge shaft seal as standard.

The operating range of the shaft seal depends on operating pressure, pump type, type of shaft seal and liquid temperature. The range shown in figs 7 and 8 applies to clean water and water with anti-freeze liquids. For selection of the right shaft seal, see section 7. *List of pumped liquids*, page 89. If the operating range is exceeded, the life of the shaft seal may be reduced.

Note that if you pump demineralised water with a conductivity below 2 µS/cm with a pump equipped with a silicon carbide/silicon carbide shaft seal, there is an increased risk of electrochemical corrosion. We recommend that you use a silicon carbide/carbon or silicon carbide/tungsten carbide shaft seal instead.

#### Optional shaft seals

See section 9. *Variants*, page 102 for optional shaft seal solutions.

### CR, CRI, CRN 1s-215

#### Ø12, Ø16 and Ø22 shaft seals (0.37-55 kW)

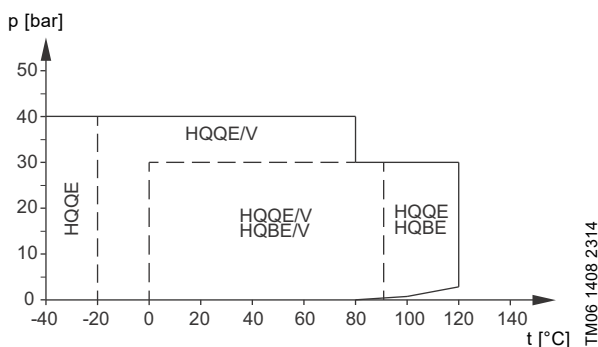

Fig. 7 Operating range of standard shaft seals for CR, CRI, CRN 1-215

Standard shaft seal	Motor size [kW]	Description	Liquid temperature [°C]
HQQE	0.37 - 55	O-ring (cartridge) (balanced seal), Silicon carbide/Silicon carbide, EPDM	-40 to +120
HQQV		O-ring (cartridge) (balanced seal), Silicon carbide/Silicon carbide, FKM	-20 to +90
HQBE		O-ring (cartridge) (balanced seal), Silicon carbide/carbon, EPDM	0 to 120
HQBV		O-ring (cartridge) (balanced seal), Silicon carbide/carbon, FKM	0 to 90

### Ø28 and Ø36 shaft seals (75-200 kW)

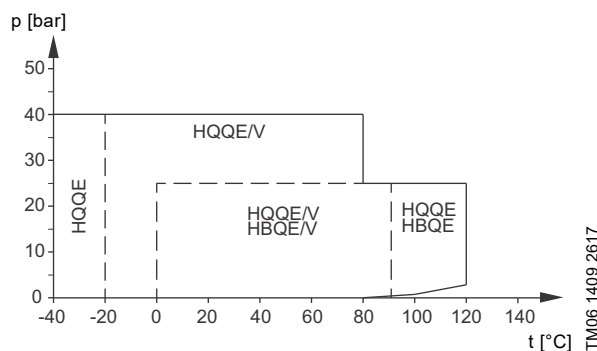

Fig. 8 Operating range of standard shaft seals for CR, CRN 125-215

Standard shaft seal	Motor size [kW]	Description	Liquid temperature [°C]
HQQE	75-200	O-ring (cartridge) (balanced seal), Silicon carbide/Silicon carbide, EPDM	-40 to +120
HQQV		O-ring (cartridge) (balanced seal), Silicon carbide/Silicon carbide, FKM	-20 to +90
HQBE		O-ring (cartridge) (balanced seal), Silicon carbide/carbon, EPDM	0 to 120
HQBV		O-ring (cartridge) (balanced seal), Silicon carbide/carbon, FKM	0 to 90

## Maximum inlet pressure

The following table shows the maximum permissible inlet pressure. However, the outlet pressure, which is the actual inlet pressure plus the pressure delivered by the pump must always be lower than the maximum permissible operating pressure.

If the maximum permissible operating pressure is exceeded, the conical bearing in the motor may be damaged and the life of the shaft seal, reduced.

Pump type and stages	Maximum inlet pressure [bar]
<b>CR, CRI, CRN 1s</b>	
1s-2 → 1s-36	10
<b>CR, CRI, CRN 1</b>	
1-2 → 1-36	10
<b>CR, CRI, CRN 3</b>	
3-2 → 3-29	10
3-31 → 3-36	15
<b>CR, CRI, CRN 5</b>	
5-2 → 5-16	10
5-18 → 5-36	15
<b>CR, CRI, CRN 10</b>	
10-1 → 10-6	8
10-7 → 10-22	10
<b>CR, CRI, CRN 15</b>	
15-1 → 15-3	8
15-4 → 15-17	10
<b>CR, CRI, CRN 20</b>	
20-1 → 20-17	10
<b>CR, CRN 32</b>	
32-1-1 → 32-4	4
32-5-2 → 32-10	10
32-11-2 → 32-14	15
<b>CR, CRN 45</b>	
45-1-1 → 45-2	4
45-3-2 → 45-5	10
45-6-2 → 45-13-2	15
<b>CR, CRN 64</b>	
64-1-1 → 64-2-2	4
64-2-1 → 64-4-2	10
64-4-1 → 64-8-1	15
<b>CR, CRN 95</b>	
95-1-1 → 95-1	4
95-2-2 → 95-3-2	10
95-3 → 95-6	15
95-7 → 95-8-2	20
<b>CR, CRN 125</b>	
125-1 → 125-2-1	10
125-2 → 125-4	15
125-5 → 125-10	20
<b>CR, CRN 155</b>	
155-1-1 → 155-1	10
155-2-2 → 155-3	15
155-4-1 → 155-8-2	20
<b>CR, CRN 185</b>	
185-1-1	10
185-1 → 185-2	15
185-3-3 → 185-8	20
<b>CR, CRN 215</b>	
215-1-1 → 215-2-2	15
215-2-1 → 215-7-2	20

## Examples of operating and inlet pressures

The values for operating and inlet pressures must not be considered individually and must comply with the below statement.

The outlet pressure must be equal to or lower than the maximum operating pressure.

See the following definitions and examples.

### Definitions

Pressure type	Definition
Maximum operating pressure	The maximum pressure is stated on the nameplate.
Pump differential pressure	The difference between the outlet pressure and inlet pressure.
Inlet pressure	The pressure measured at the pump inlet.
Outlet pressure	The inlet pressure added to the pump differential pressure.

### Example 1

Pump, see page 40:	CR 5-16 A-A-A
Max. operating pressure:	16 bar
Max. inlet pressure:	10 bar
Pump differential pressure:	10.6 bar*
	* Flow = 0 m <sup>3</sup> /h

This pump is not allowed to start at an inlet pressure of 10 bar, but at an inlet pressure of 16.0 - 10.6 = 5.4 bar.

### Example 2

Pump, see page 44:	CR 10-2 A-A-A
Max. operating pressure:	16 bar
Max. inlet pressure:	8 bar
Pump differential pressure:	2 bar*
	* Flow = 0 m <sup>3</sup> /h

This pump is allowed to start at an inlet pressure of 8 bar, as the outlet pressure is lower than the maximum operating pressure. This results in an operating pressure of 8 + 2 = 10 bar.

If the inlet or operating pressure exceeds the pressure permitted, see section 9. *Variants*, page 102.

## 4. Selection

### Selection of pumps

Base the selection of pumps on these parameters:

- Duty point of the pump. See page 23.
- Sizing data such as pressure loss as a result of height differences, friction in the pipes, pump efficiency. See page 23.
- Pump materials. See page 24.
- Pump connections. See page 24.
- Shaft seal. See page 24.

#### Duty point of the pump

From a duty point, you can select a pump on the basis of the curve charts in section 5. *Performance curves and technical data*, page 28.

Ideally, the duty point should match the best efficiency on the pump curve. See the example in Fig. 10.

#### Sizing data

When sizing a pump, take these parameters into account:

- Required flow rate and pressure at the draw-off point.
- Pressure loss as a result of height differences ( $H_{geo}$ ).
- Friction loss in the pipes ( $H_f$ ).  
It may be necessary to account for pressure loss in connection with long pipes, bends, valves or similar.
- Best efficiency at the estimated duty point.
- NPSH value.

For calculation of the NPSH value, see *Minimum inlet pressure, NPSH*, page 25.

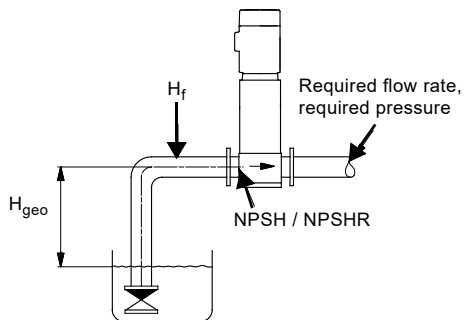

Fig. 9 Sizing data

#### Pump efficiency

Before determining the best efficiency point, identify the operation pattern of the pump. If the pump is expected to always operate at the same duty point, select a pump which is operating at a duty point corresponding to the best efficiency of the pump.

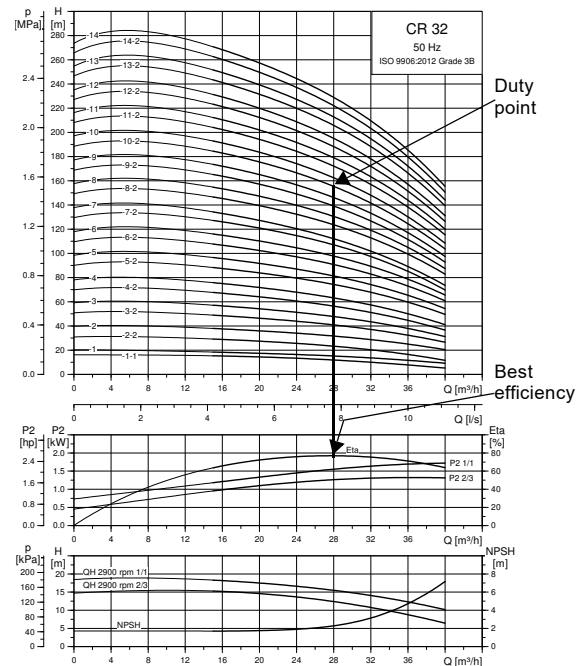

Fig. 10 Example of a CR pump's duty point

As the pump is sized on the basis of the highest possible flow rate, it is important to always have the duty point to the right of the best efficiency point on the efficiency curve (eta). This must be considered in order to keep the efficiency high when the flow rate drops.

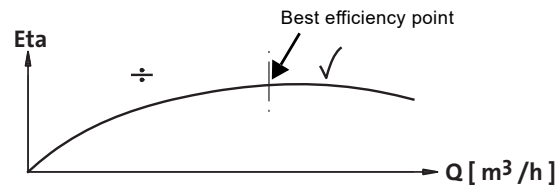

Fig. 11 Best efficiency

#### Grundfos Product Center

We recommend that you size your pump in Grundfos Product Center, which is a selection program offered by Grundfos. For further information, see [Grundfos Product Center](#).

Grundfos Product Center features a user-friendly and easy-to-use virtual guide which leads you through the selection of the pump for the application in question.

TM02 6711 1403

TM02 7302 0918

TM00 9190 1303

### Pump material

Select the material variant on the basis of the liquid to be pumped.

The product range covers the following basic types.

- CR, CRI  
Use CR, CRI pumps for clean, non-aggressive liquids, such as potable water and oils.
- CRN  
Use CRN pumps for industrial liquids and acids.  
See section 7. *List of pumped liquids*, page 89, or contact Grundfos.

For saline or chloride-containing liquids, such as sea water, CRT pumps of titanium are available.

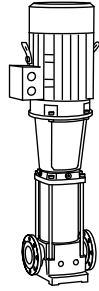

Fig. 12 CR pump

### Pump connections

Selection of a pump connection depends on the rated pressure and the pipes. To meet any requirement, the CR, CRI and CRN pumps offer a wide range of flexible connections, such as:

- oval flange (BSP)
- DIN flange
- PJE coupling (Victaulic type)
- clamp coupling
- union (+GF+)
- other connections on request.

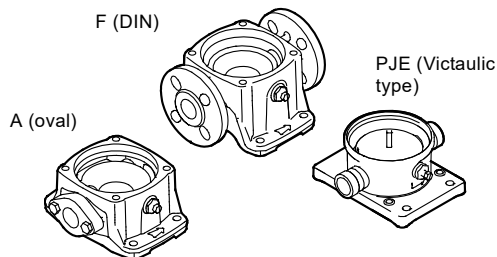

Fig. 13 Pump connections

TM01 2100 1198

TM02 1201 0601

### Shaft seal



GR7386

Fig. 14 Shaft seal (cartridge type)

As standard, the CR range is fitted with a Grundfos shaft seal (cartridge type), which is suitable for the most common applications.

The following key parameters must be taken into account when selecting the shaft seal:

- type of pumped liquid
- liquid temperature
- maximum pressure.

We offer a wide range of shaft seal variants to meet specific demands. See section 7. *List of pumped liquids*.

### Servicing shaft seals

Replacement shaft seals are available as complete service kits\*.

Shaft seals fitted on CR, CRN 125-215 pumps with  $\varnothing 28$  mm or  $\varnothing 36$  mm shaft ends are serviceable. This means that the wear parts in these shaft seals are available as service kits\* and can be replaced without having to renew the complete shaft seal.

\* All service kits include detailed instructions on how to carry out the replacement.

**Thrust handling device**

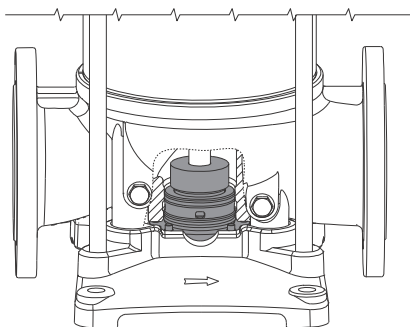

TM06 9669 2817

**Fig. 15** Thrust handling device

A thrust handling device (THD) is factory-fitted on pumps with 75 kW motors or larger. The system consists of two parts. A rotating part mounted on the shaft end below the first impeller as well as a non-rotating part mounted in or on the pump base. The THD absorbs the main part of the thrust force generated by the impellers and thereby reduces the resulting axial force the motor bearings must absorb. This enables the use of standard ball bearings in the motor instead of special angular contact ball bearings. Note: For applications involving CIP (clean-in-place) and motors above 55 kW, use a bearing flange and a base without THD.

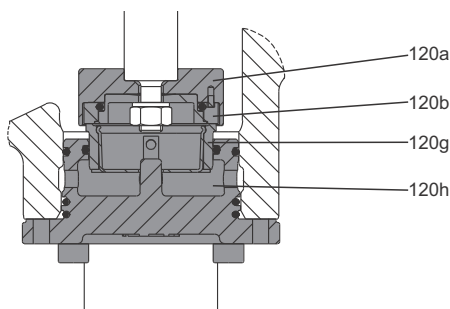

TM06 9670 2817

**Fig. 16** Position numbers for THD parts

Pos.	Description	Material
120a	Thrust disc	Stainless steel
120b	Rotating ring	Silicon carbide
120g	Stationary ring	Silicon carbide* Tungsten carbide
120h	Lifting plate	Stainless steel
-	O-rings	EPDM FKM

\* On request for CRN.

**Operating pressure and inlet pressure**

Do not exceed the limit values for these pressures:

- maximum operating pressure
- maximum inlet pressure.

**Minimum inlet pressure, NPSH**

We recommend that you calculate the inlet pressure "H" in these situations:

- The liquid temperature is high.
- The flow rate is significantly higher than the rated flow rate.
- Water is drawn from depths.
- Water is drawn through long pipes.
- Inlet conditions are poor.

To avoid cavitation, make sure that there is a minimum pressure on the inlet side of the pump.

Calculate the maximum suction lift "H" in metres head as follows:

$$H = p_b \times 10.2 - NPSH - H_f - H_v$$

$p_b$  = Barometric pressure in bar.  
 $p_b$  can be set to 1 bar at sea level.

In closed systems,  $p_b$  indicates the system pressure in bar.

NPSH = Net Positive Suction Head in metres head.  
 To be read from the NPSH curve at the highest flow rate the pump will be delivering.

$H_f$  = Friction loss in inlet pipe in metres head at the highest flow rate the pump will be delivering.

$H_v$  = Vapour pressure in metres head. To be read from the vapour pressure scale.  
 $H_v$  depends on the liquid temperature  $t_m$ .

If the calculated "H" is positive, the pump can operate at a suction lift of maximum "H" m head.

If the calculated "H" is negative, an inlet pressure of minimum "H" m head is required.

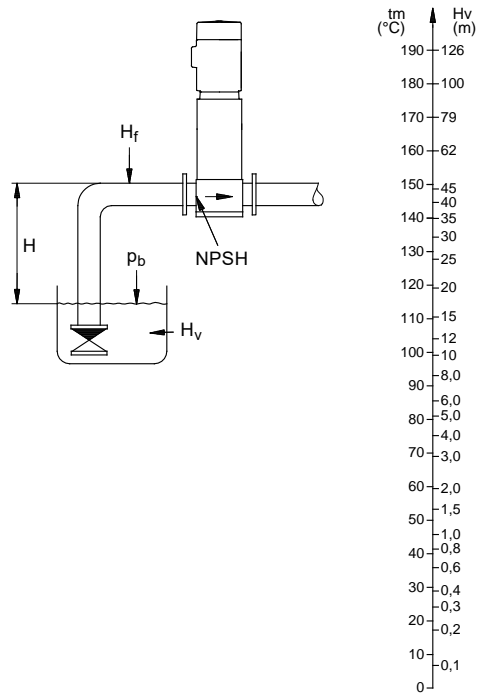

TM02 7439 3403

**Fig. 17** Minimum inlet pressure, NPSH

To avoid cavitation, do not select a pump with a duty point too far to the right on the NPSH curve.

Always check the NPSH value of the pump at the highest possible flow rate.

## How to read the curve charts

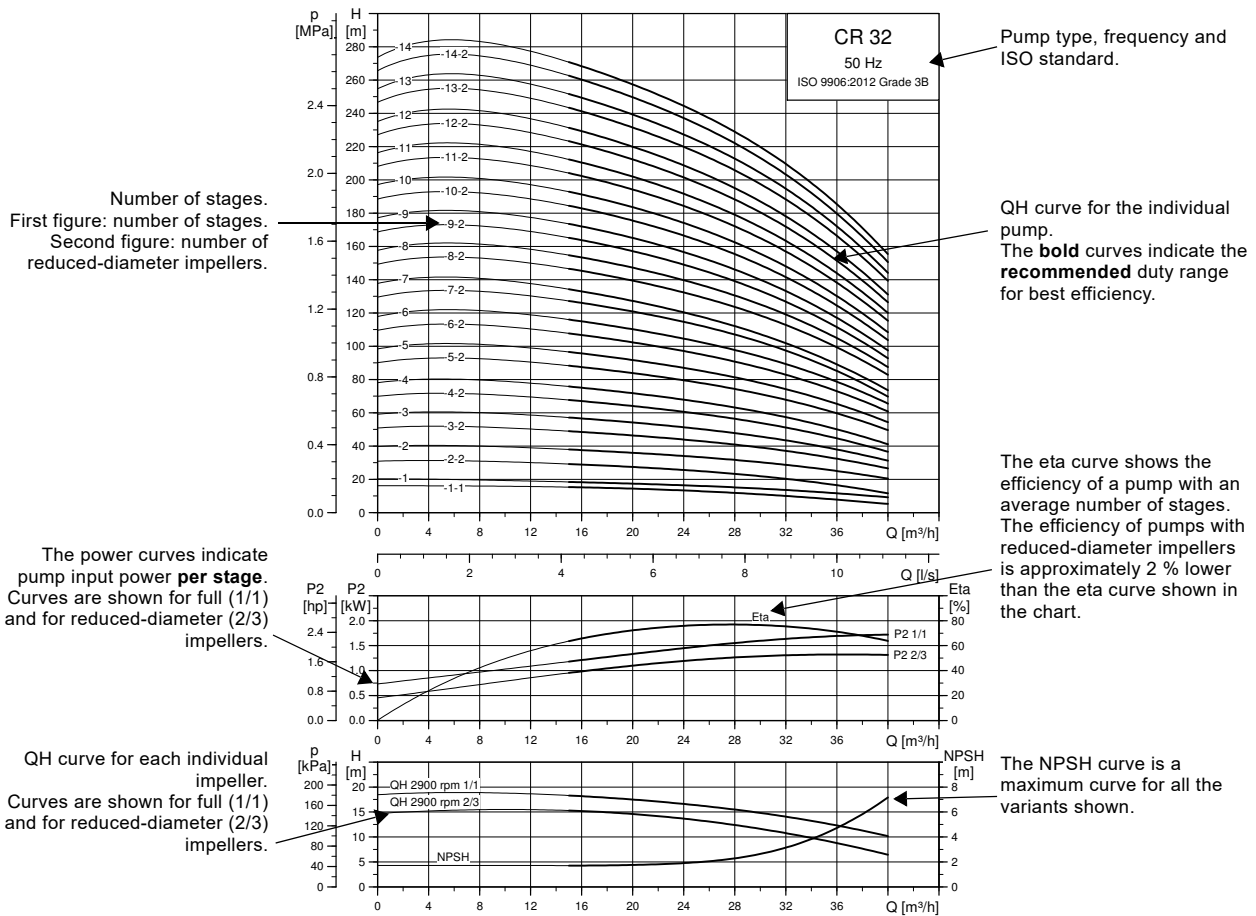

Fig. 18 How to read the curve charts

## Guidelines to performance curves

The guidelines below apply to the curves shown on the following pages:

- Tolerances to ISO 9906:2012, Grade 3B, if indicated on the curve chart.
- The motors used for the measurements are standard Grundfos MG motors.
- Measurements have been made with airless water at a temperature of 20 °C.
- The curves apply to the following kinematic viscosity:  $\nu = 1 \text{ mm}^2/\text{s}$  (1 cSt).
- Due to the risk of overheating, the pumps must not be used at a flow rate below the minimum flow rate.
- The QH curves apply to a rated motor speed of a three-phase mains-operated motor. For realistic curves, go to Grundfos Product Center (<http://product-selection.grundfos.com/>), and insert data.

The curve below shows the minimum flow rate as a percentage of the rated flow rate in relation to the liquid temperature. The dotted line shows a CR pump fitted with an air-cooled top assembly.

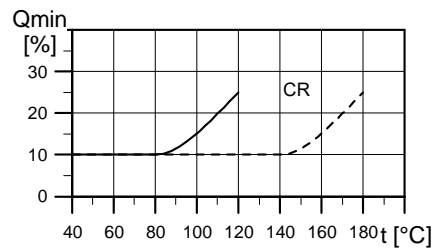

Fig. 19 Minimum flow rate

TM02 7302 0918

TM01 2816 0303

# 5. Performance curves and technical data

## CR 1s

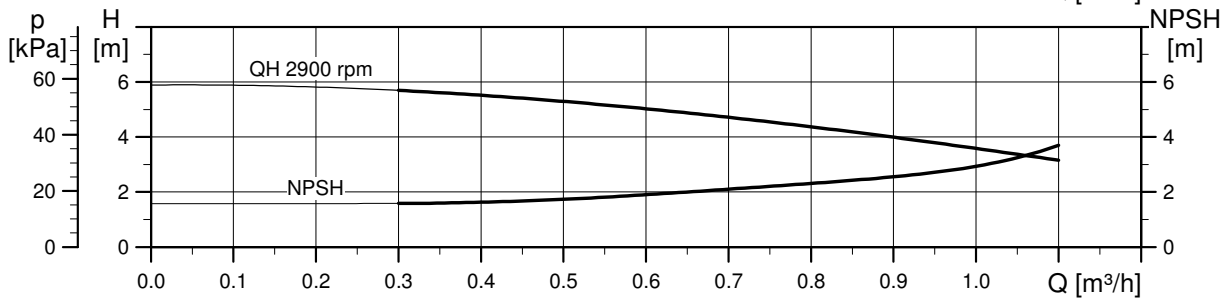
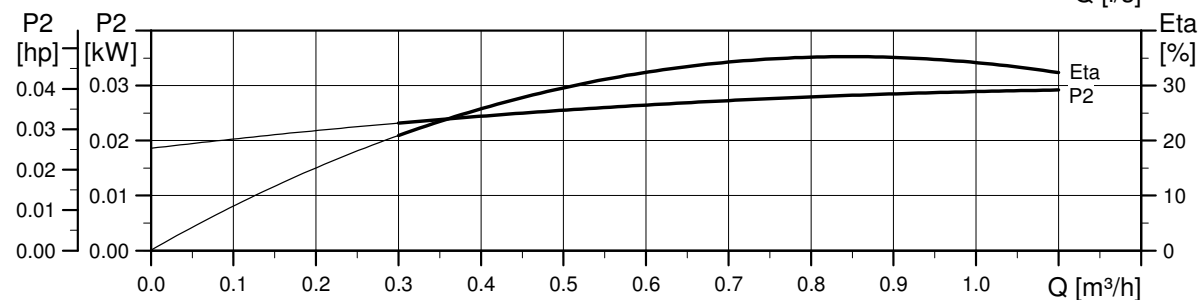
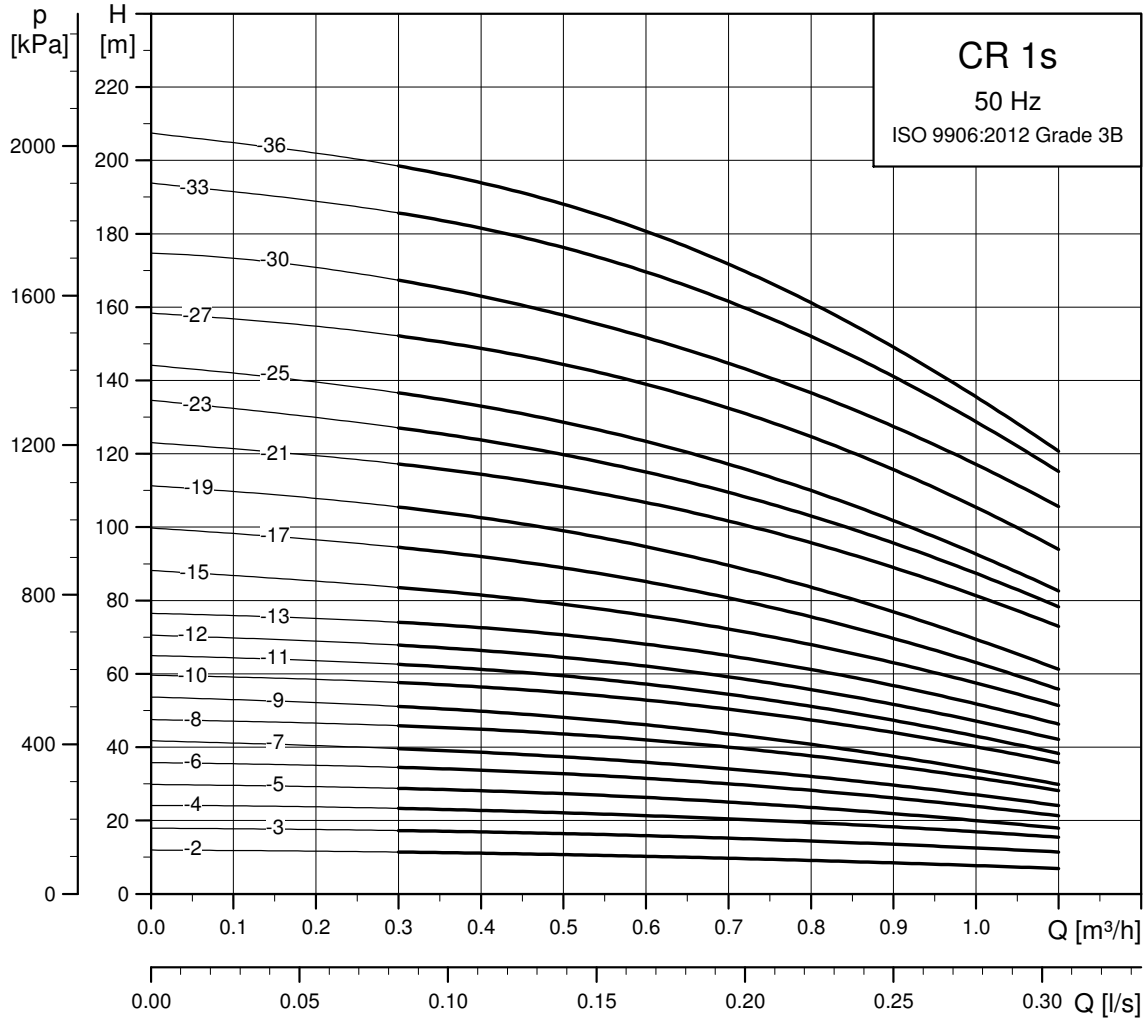

TM02 7424 0918



CRI, CRN 1s

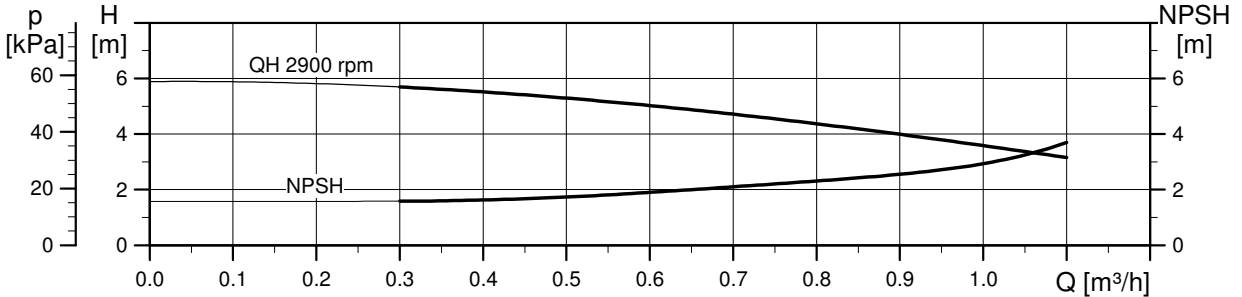
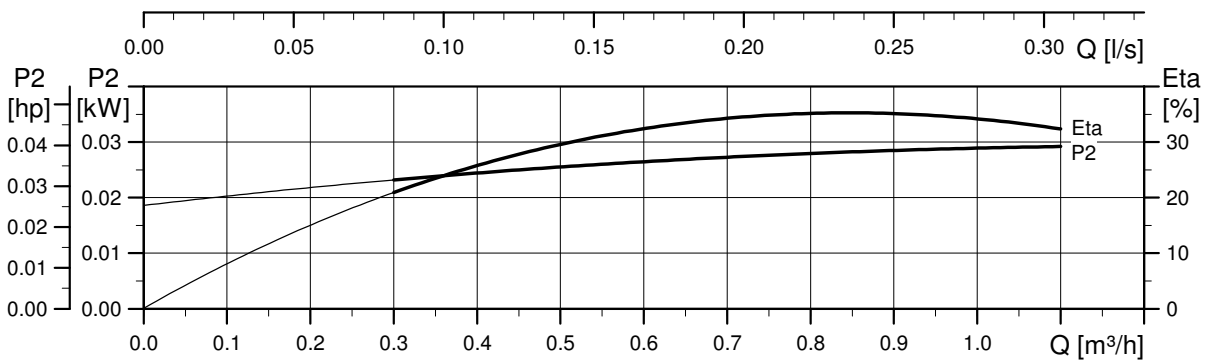
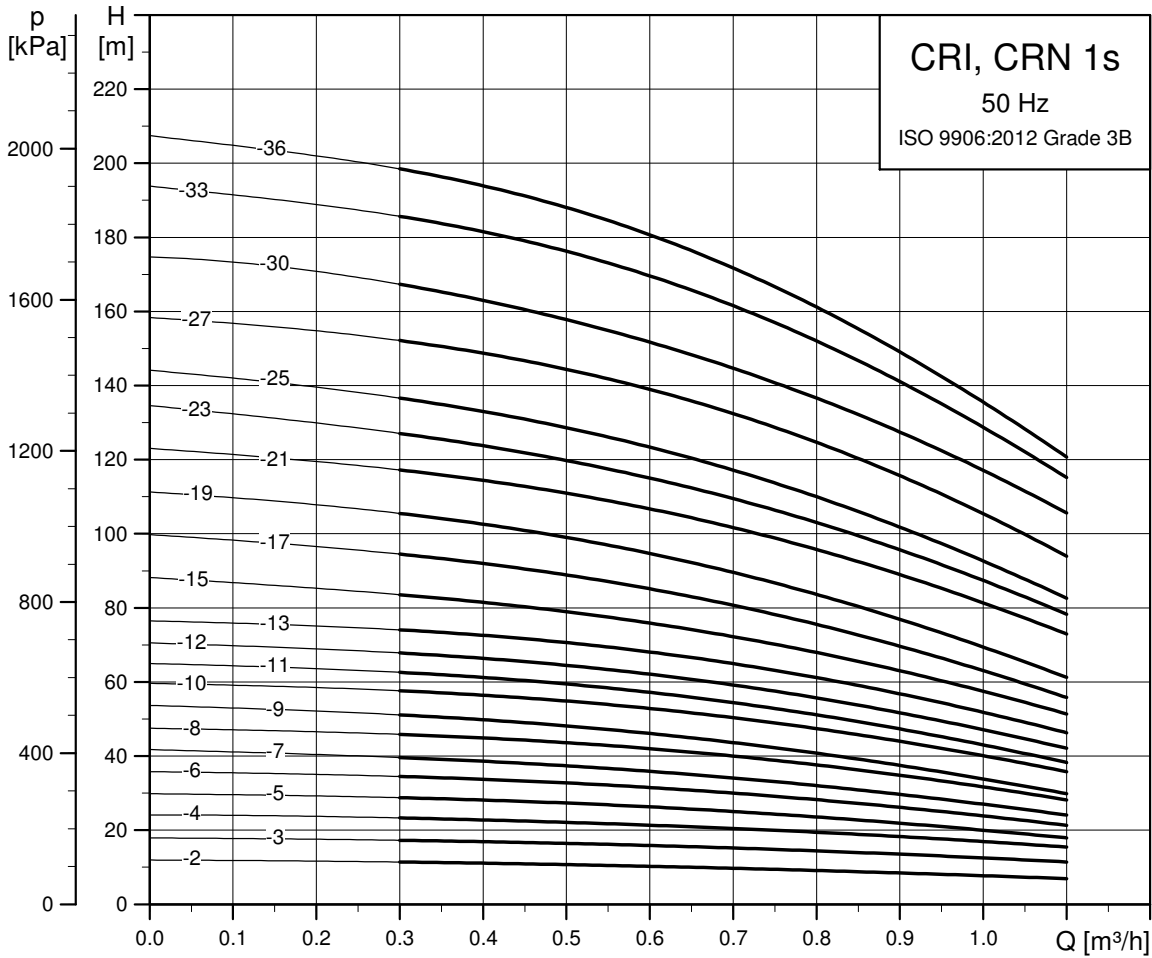

TM02 7425 0918

Dimensional sketch

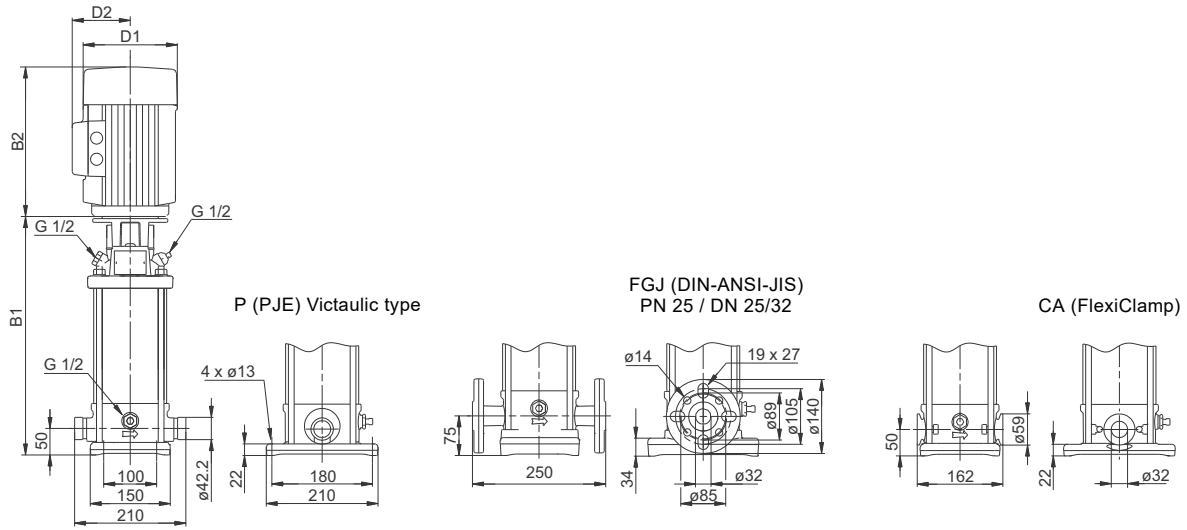

TM06 9592 2517

Dimensions and weights

Pump type	Motor P <sub>2</sub> [kW]	Dimension [mm]				Net weight [kg]			
		PJE/CA		DIN flange		D1	D2	PJE/CA	DIN flange
		B1	B1+B2	B1	B1+B2				
CRI/CRN 1s-2	0.37	257	448	282	473	141	109	16	20
CRI/CRN 1s-3	0.37	257	448	282	473	141	109	17	21
CRI/CRN 1s-4	0.37	275	466	300	491	141	109	17	21
CRI/CRN 1s-5	0.37	293	484	318	509	141	109	17	22
CRI/CRN 1s-6	0.37	311	502	336	527	141	109	18	22
CRI/CRN 1s-7	0.37	329	520	354	545	141	109	18	22
CRI/CRN 1s-8	0.37	347	538	372	563	141	109	19	23
CRI/CRN 1s-9	0.37	365	556	390	581	141	109	19	23
CRI/CRN 1s-10	0.37	383	574	408	599	141	109	19	24
CRI/CRN 1s-11	0.37	401	592	426	617	141	109	20	24
CRI/CRN 1s-12	0.37	419	610	444	635	141	109	20	24
CRI/CRN 1s-13	0.37	437	628	462	653	141	109	21	25
CRI/CRN 1s-15	0.55	473	664	498	689	141	109	21	25
CRI/CRN 1s-17	0.55	509	700	534	725	141	109	22	26
CRI/CRN 1s-19	0.55	545	736	570	761	141	109	22	27
CRI/CRN 1s-21	0.75	587	818	612	843	141	109	27	31
CRI/CRN 1s-23	0.75	623	854	648	879	141	109	27	32
CRI/CRN 1s-25	0.75	659	890	684	915	141	109	28	32
CRI/CRN 1s-27	1.1	695	946	720	971	141	109	31	35
CRI/CRN 1s-30	1.1	749	1000	774	1025	141	109	32	36
CRI/CRN 1s-33	1.1	803	1054	828	1079	141	109	33	38
CRI/CRN 1s-36	1.1	857	1108	882	1133	141	109	35	39

CR 1

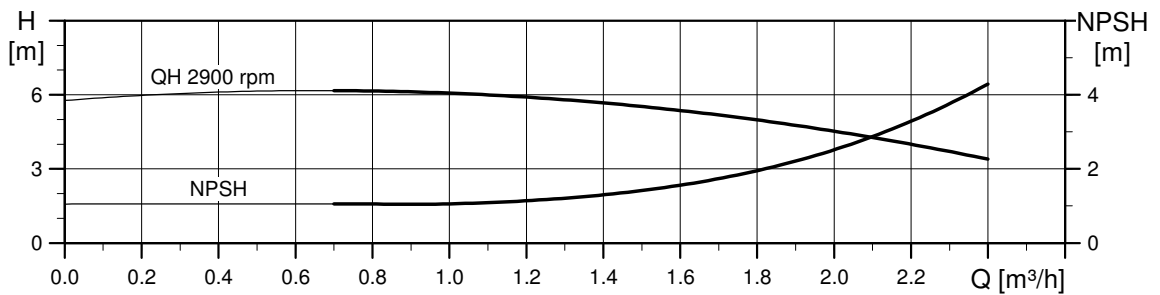
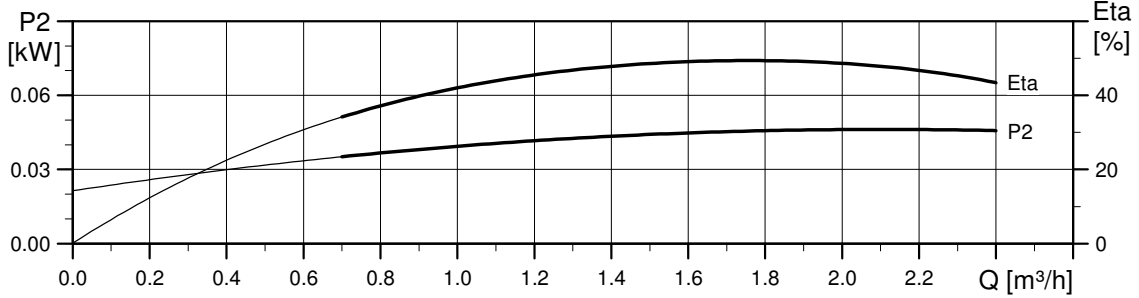
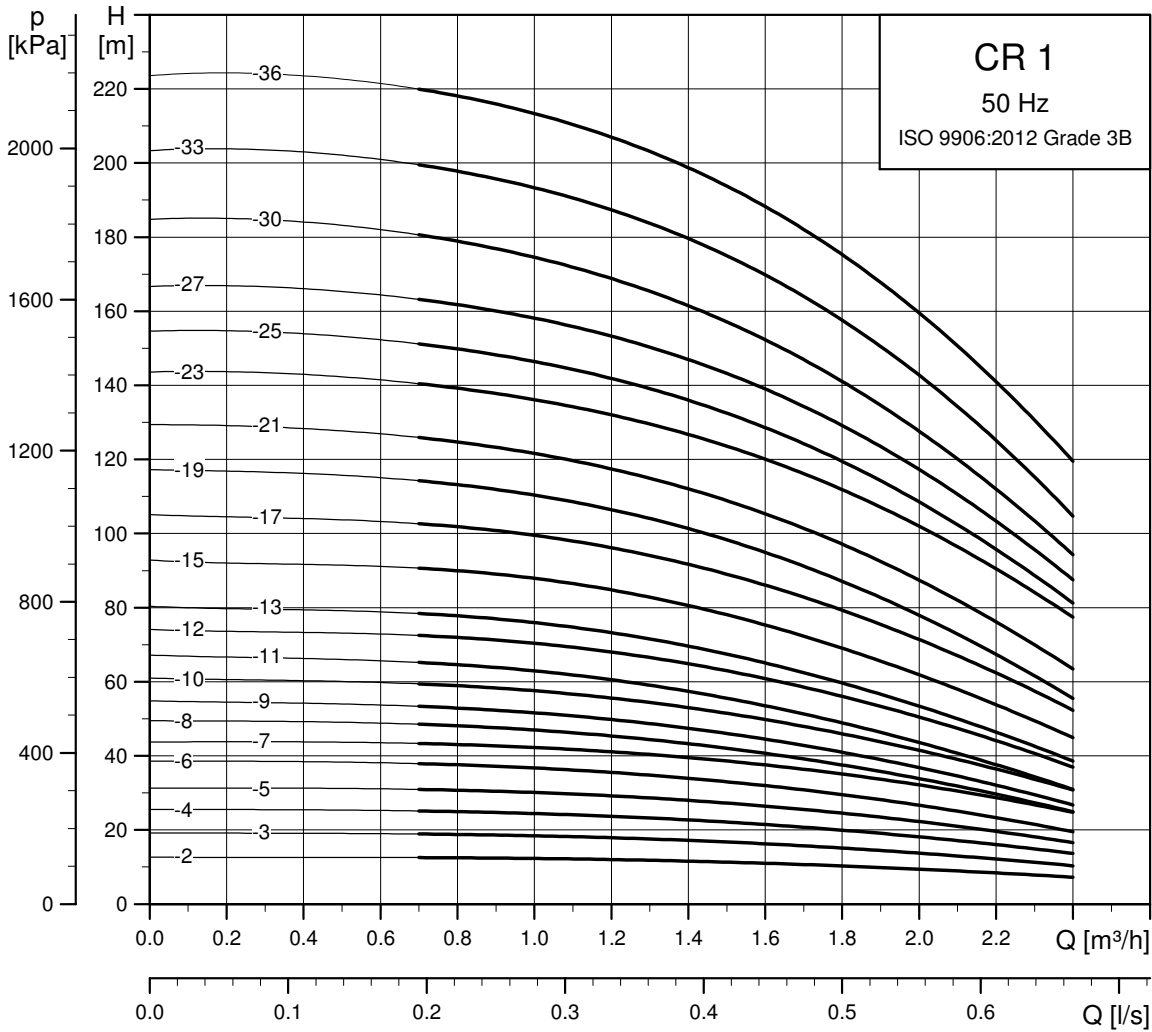

TM02 7290 0918



**CRI, CRN 1**

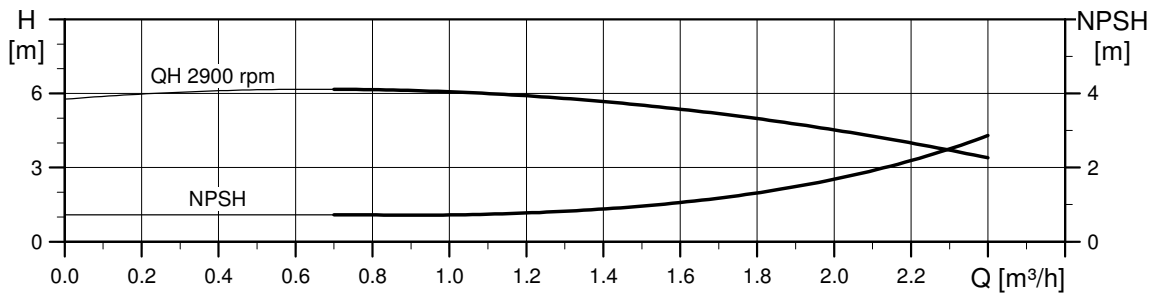
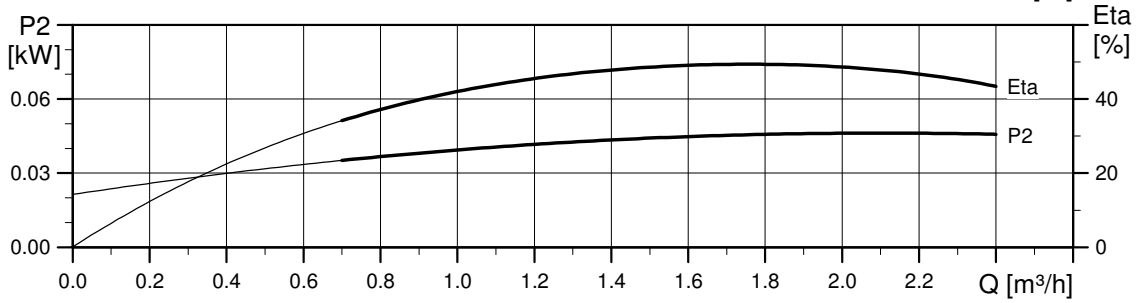
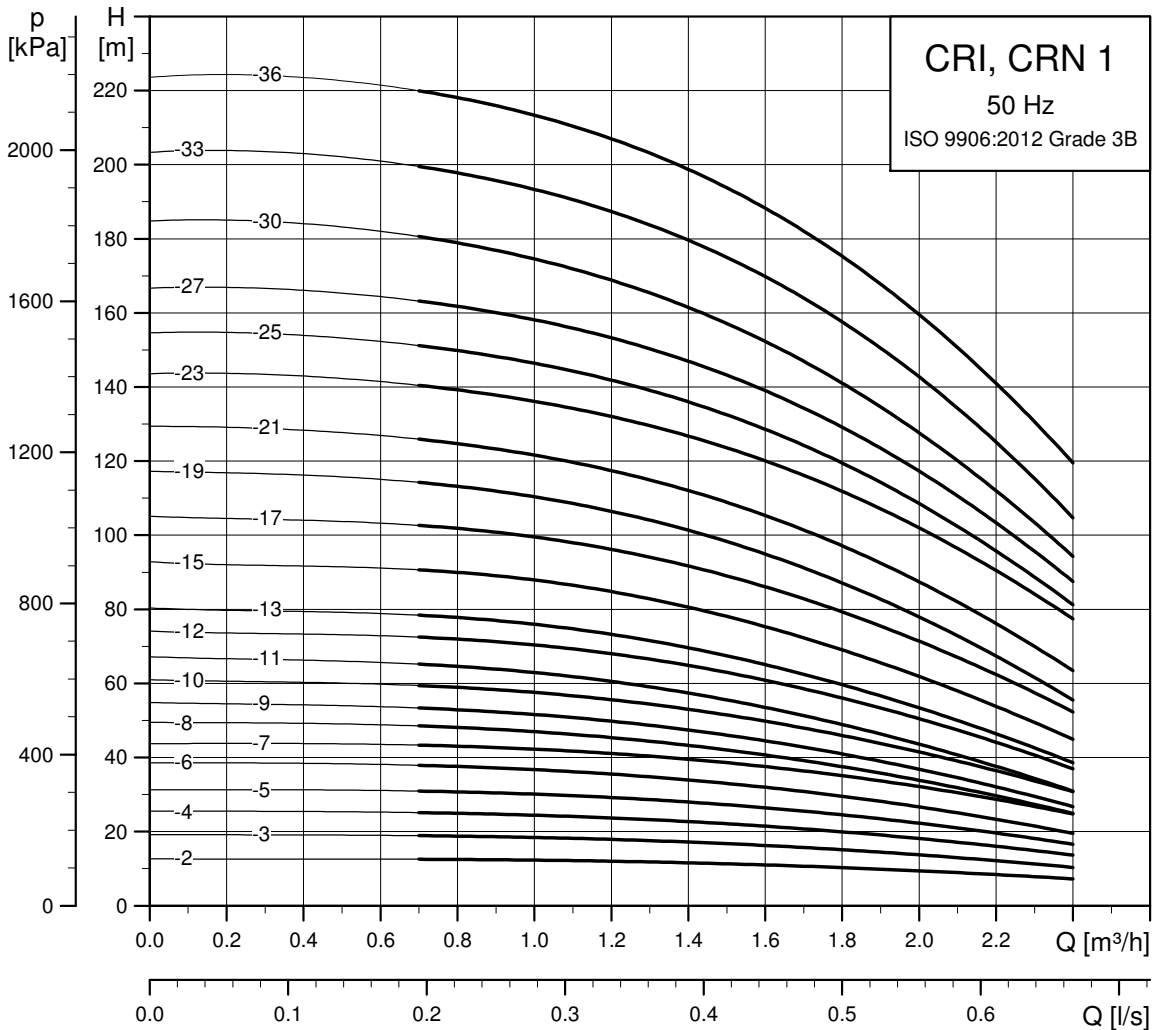

TM02 7291 0918

Dimensional sketch

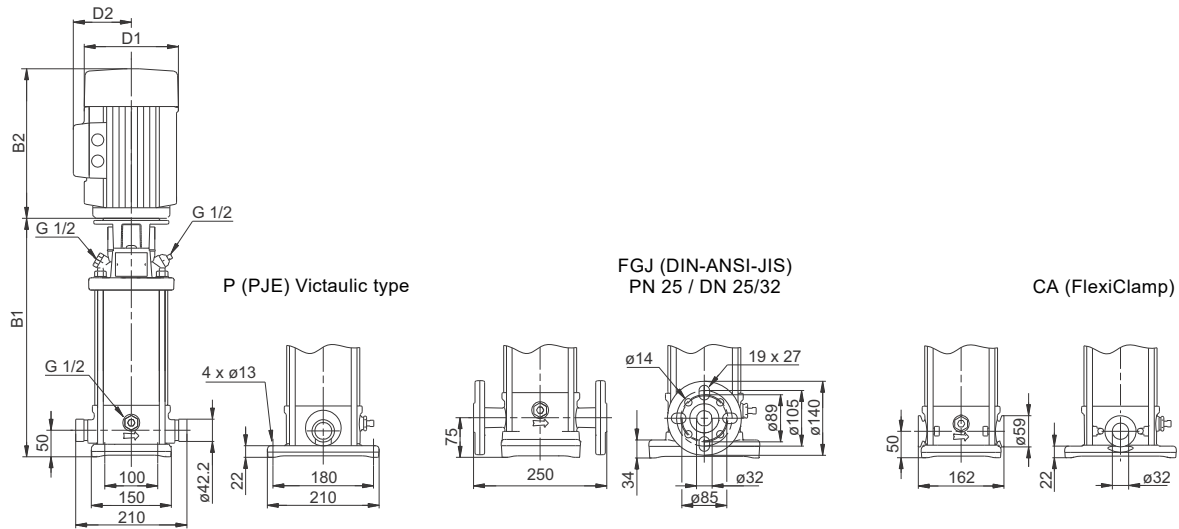

TM06 9592 2517

Dimensions and weights

Pump type	Motor P <sub>2</sub> [kW]	CRI/CRN							
		Dimension [mm]						Net weight [kg]	
		PJE/CA		DIN flange		D1	D2	PJE/CA	DIN flange
B1	B1+B2	B1	B1+B2						
CRI/CRN 1-2	0.37	257	448	282	473	141	109	16	21
CRI/CRN 1-3	0.37	257	448	282	473	141	109	17	21
CRI/CRN 1-4	0.37	275	466	300	491	141	109	17	21
CRI/CRN 1-5	0.37	293	484	318	509	141	109	17	22
CRI/CRN 1-6	0.37	311	502	336	527	141	109	18	22
CRI/CRN 1-7	0.37	329	520	354	545	141	109	18	22
CRI/CRN 1-8	0.55	347	538	372	563	141	109	18	22
CRI/CRN 1-9	0.55	365	556	390	581	141	109	19	23
CRI/CRN 1-10	0.55	383	574	408	599	141	109	19	23
CRI/CRN 1-11	0.55	401	592	426	617	141	109	19	23
CRI/CRN 1-12	0.75	425	656	450	681	141	109	23	27
CRI/CRN 1-13	0.75	443	674	468	699	141	109	24	28
CRI/CRN 1-15	0.75	479	710	504	735	141	109	24	29
CRI/CRN 1-17	1.1	515	766	540	791	141	109	27	31
CRI/CRN 1-19	1.1	551	802	576	827	141	109	28	32
CRI/CRN 1-21	1.1	587	838	612	863	141	109	29	33
CRI/CRN 1-23	1.1	623	874	648	899	141	109	30	34
CRI/CRN 1-25	1.5	675	956	700	981	178	110	36	40
CRI/CRN 1-27	1.5	711	992	736	1017	178	110	37	41
CRI/CRN 1-30	1.5	765	1046	790	1071	178	110	38	43
CRI/CRN 1-33	2.2	819	1140	844	1165	178	110	43	48
CRI/CRN 1-36	2.2	873	1194	898	1219	178	110	45	49

CR 3

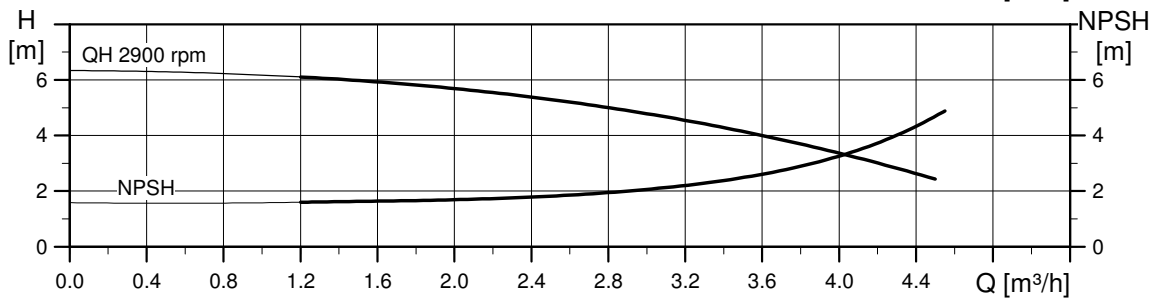
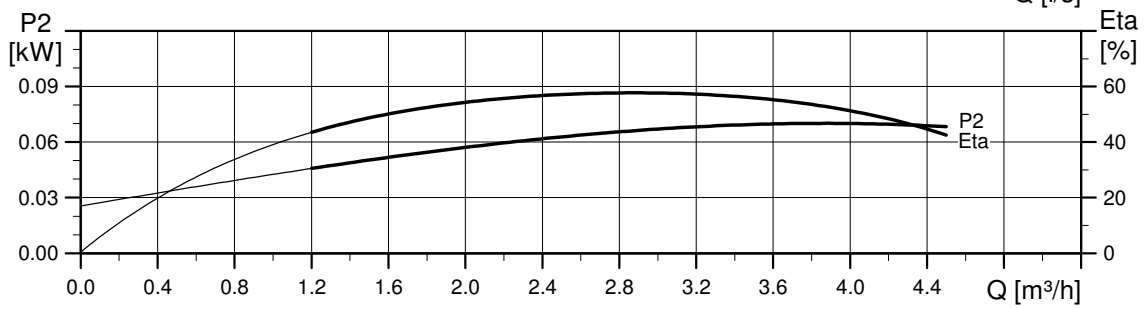
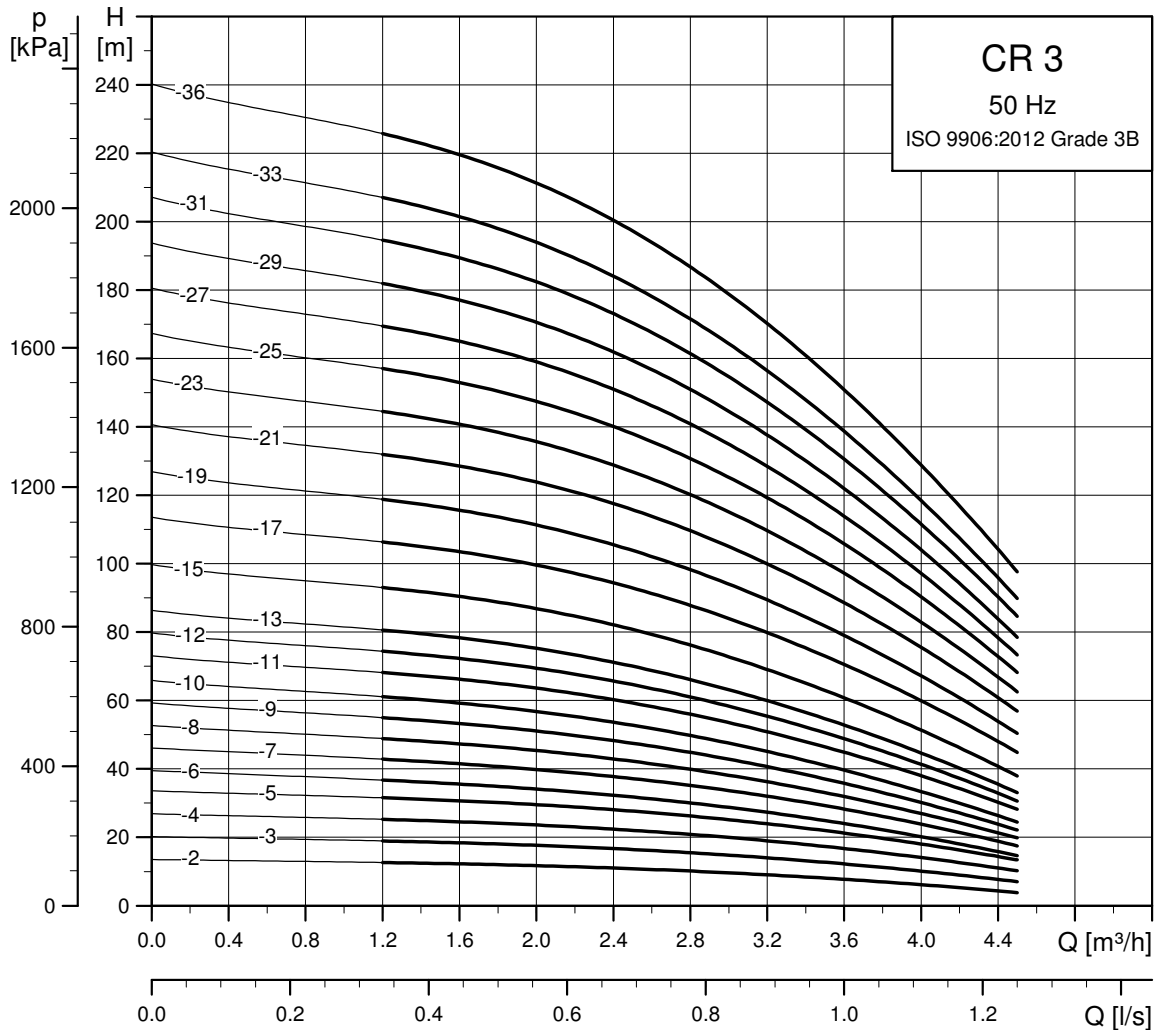

TM02 7292 0918



**CRI, CRN 3**

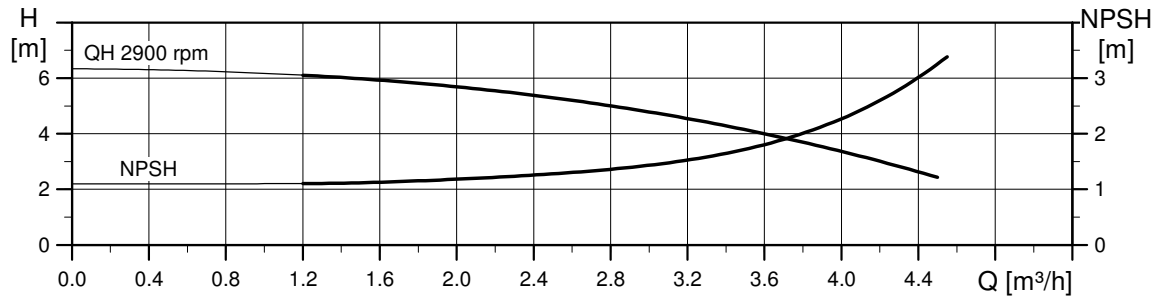
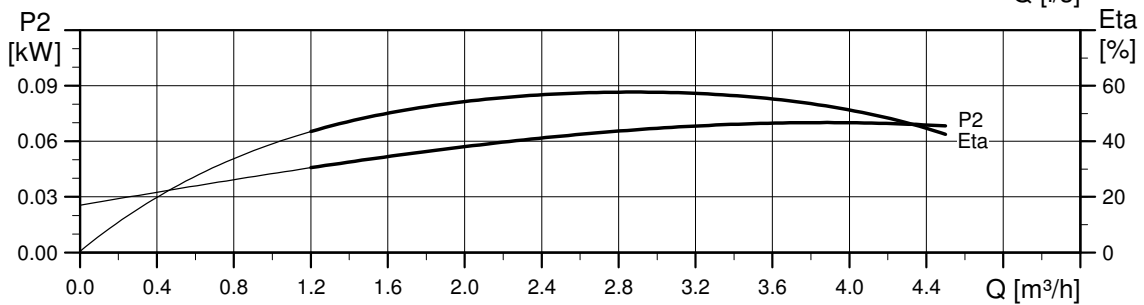
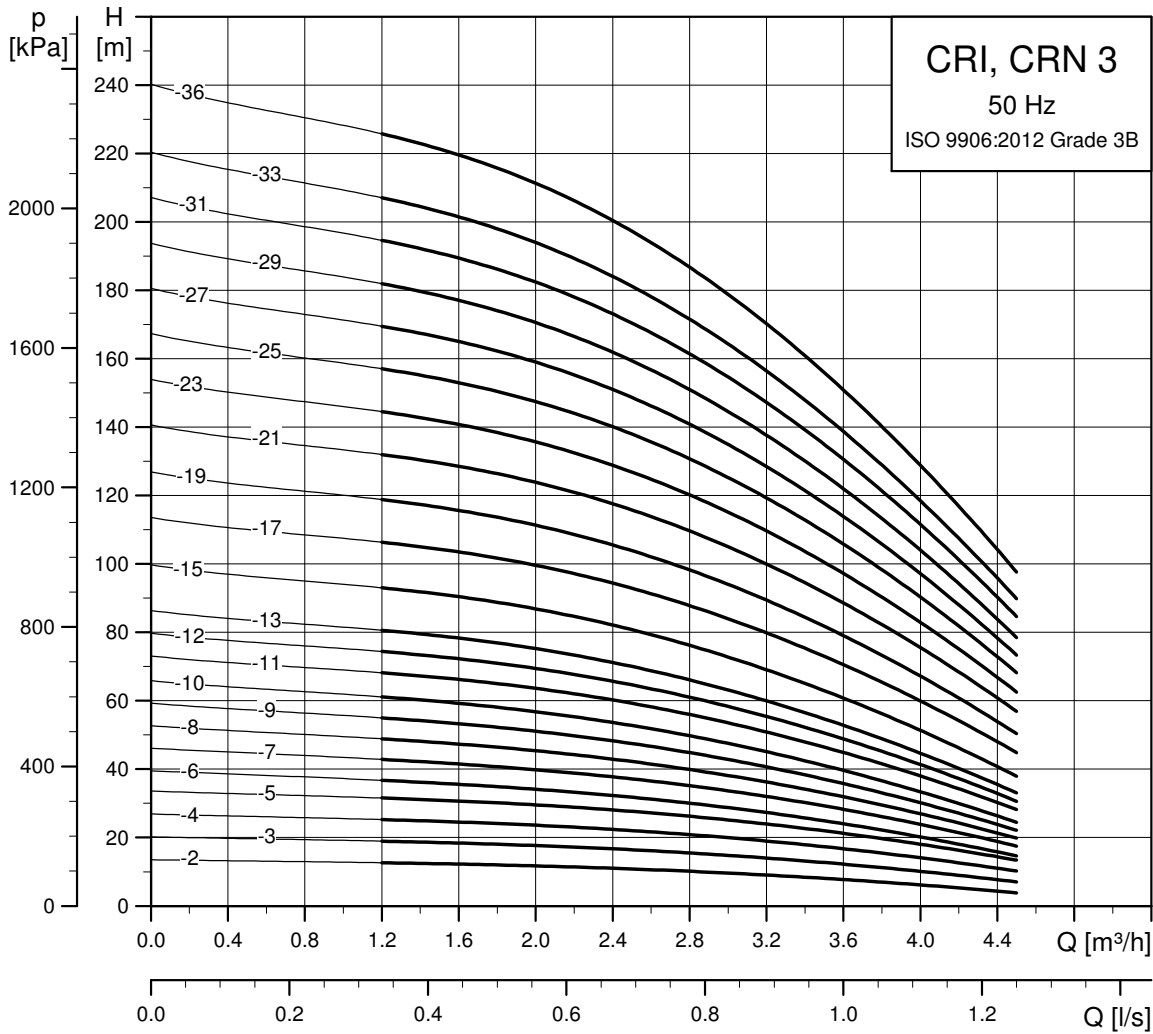

TM02 7293 0918

Dimensional sketch

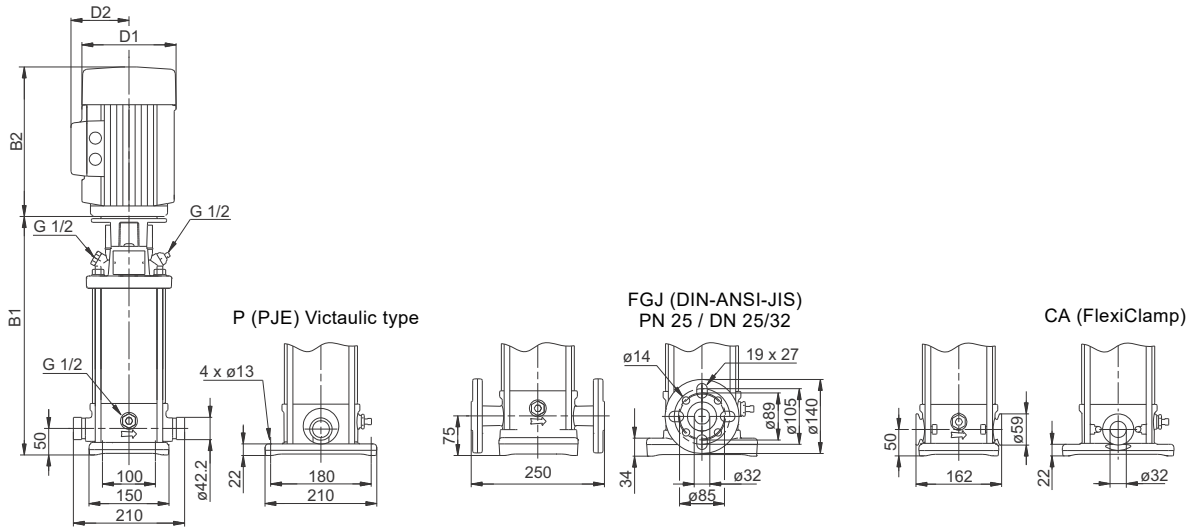

TM06 9592 2517

Dimensions and weights

Pump type	Motor P <sub>2</sub> [kW]	CRI/CRN							
		Dimension [mm]				Net weight [kg]			
		PJE/CA		DIN flange		D1	D2	PJE/CA	DIN flange
B1	B1+B2	B1	B1+B2						
CRI/CRN 3-2	0.37	257	448	282	473	141	109	16	21
CRI/CRN 3-3	0.37	257	448	282	473	141	109	17	21
CRI/CRN 3-4	0.37	275	466	300	491	141	109	17	21
CRI/CRN 3-5	0.37	293	484	318	509	141	109	17	22
CRI/CRN 3-6	0.55	311	502	336	527	141	109	17	22
CRI/CRN 3-7	0.55	329	520	354	545	141	109	18	22
CRI/CRN 3-8	0.75	353	584	378	609	141	109	22	26
CRI/CRN 3-9	0.75	371	602	396	627	141	109	22	26
CRI/CRN 3-10	0.75	389	620	414	645	141	109	22	27
CRI/CRN 3-11	1.1	407	658	432	683	141	109	25	29
CRI/CRN 3-12	1.1	425	676	450	701	141	109	25	29
CRI/CRN 3-13	1.1	443	694	468	719	141	109	26	30
CRI/CRN 3-15	1.1	479	730	504	755	141	109	26	31
CRI/CRN 3-17	1.5	531	812	556	837	178	110	33	37
CRI/CRN 3-19	1.5	567	848	592	873	178	110	34	38
CRI/CRN 3-21	2.2	603	924	628	949	178	110	39	43
CRI/CRN 3-23	2.2	639	960	664	985	178	110	39	43
CRI/CRN 3-25	2.2	675	996	700	1021	178	110	40	44
CRI/CRN 3-27	2.2	711	1032	736	1057	178	110	41	45
CRI/CRN 3-29	2.2	747	1068	772	1093	178	110	42	46
CRI/CRN 3-31	3	788	1123	813	1148	198	120	48	52
CRI/CRN 3-33	3	824	1159	849	1184	198	120	49	53
CRI/CRN 3-36	3	878	1213	903	1238	198	120	50	54

CR 5

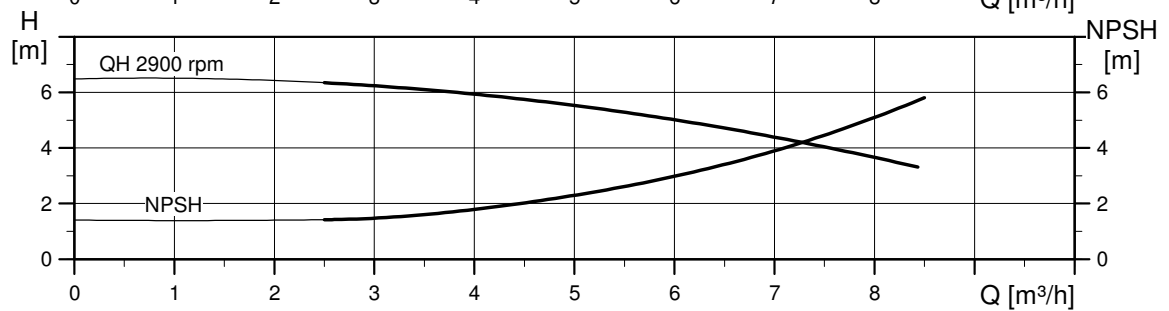
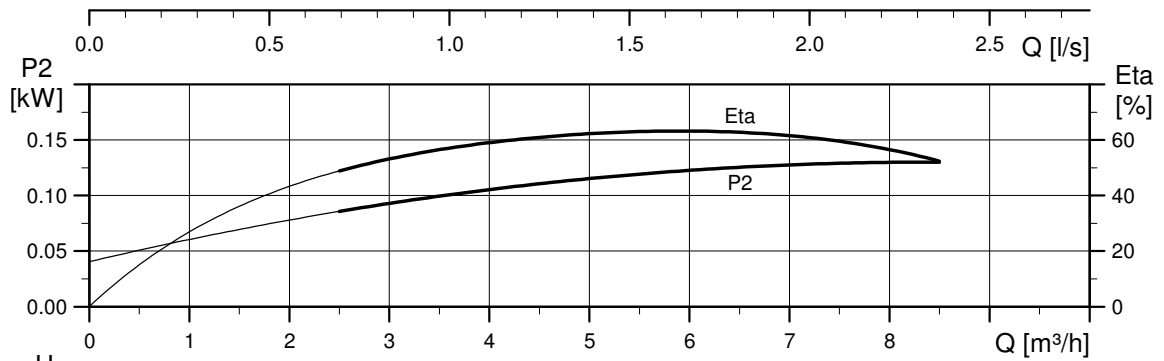
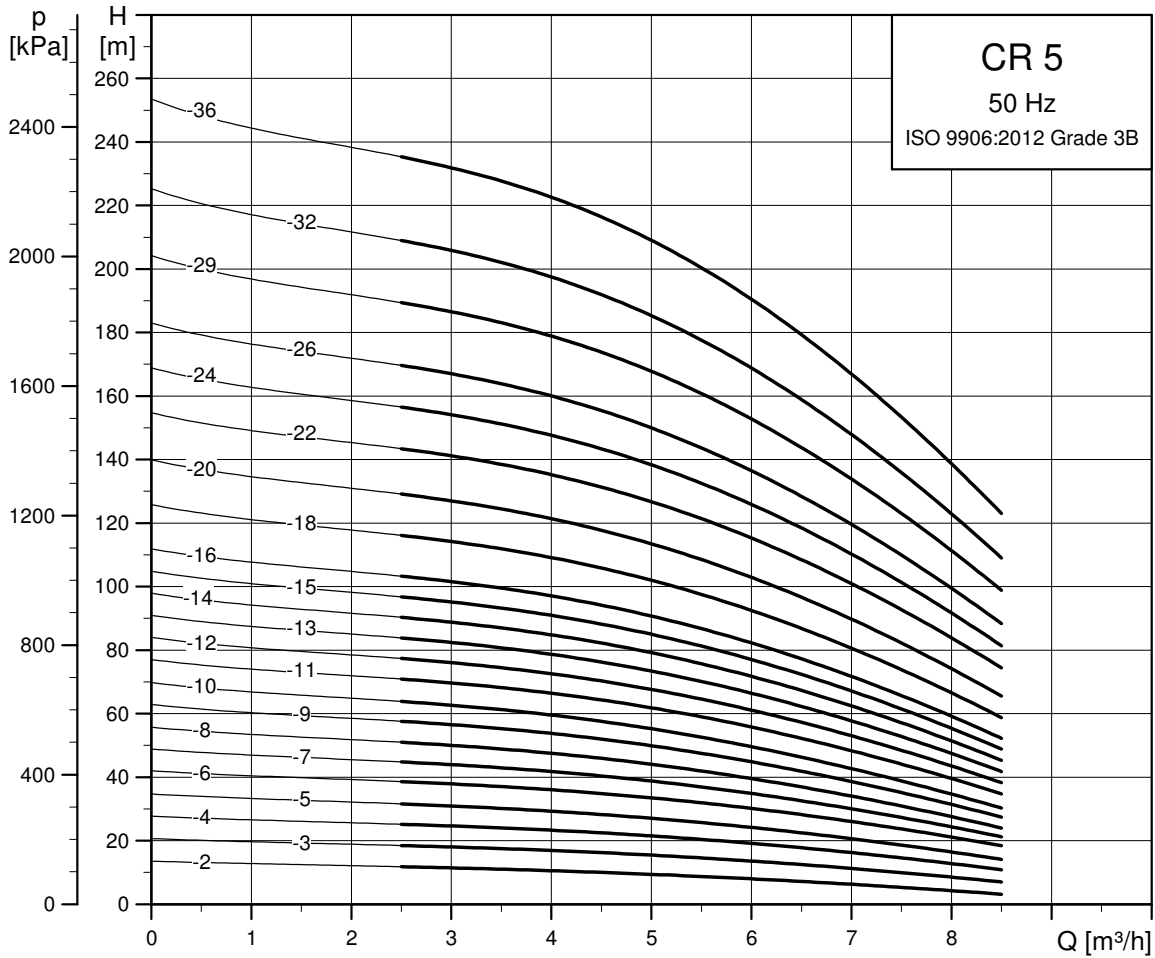

TM02 7294 0918

Dimensional sketch

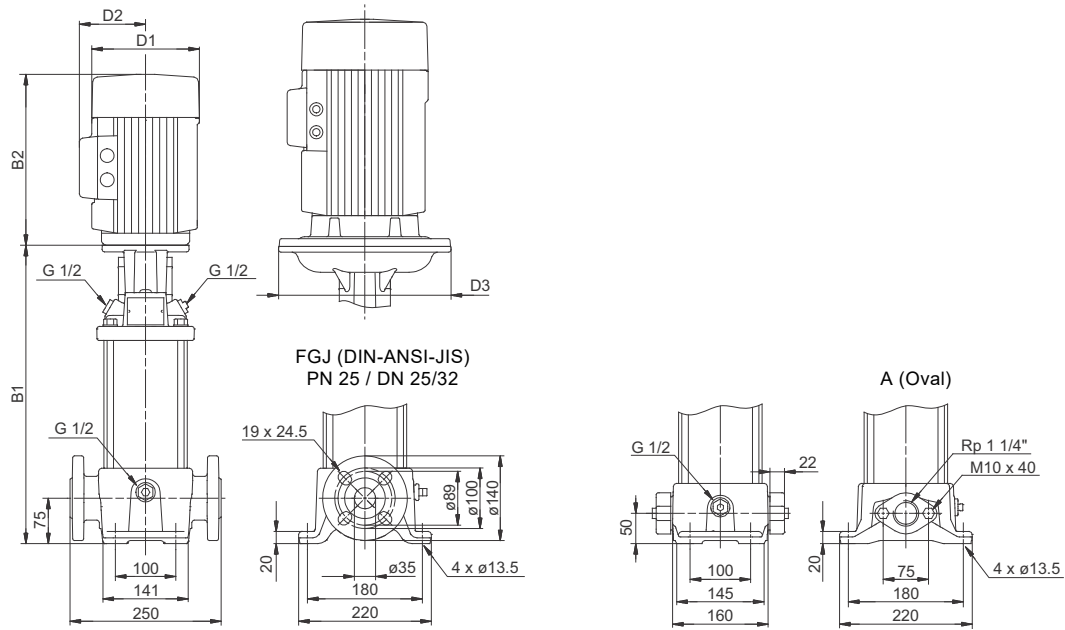

TM06 9593 2517

Dimensions and weights

Pump type	Motor P <sub>2</sub> [kW]	CR								
		Dimension [mm]						Net weight [kg]		
		Oval flange		DIN flange		D1	D2	D3	Oval flange	DIN flange
B1	B1+B2	B1	B1+B2	D1	D2	D3	Oval flange	DIN flange		
CR 5-2	0.37	254	445	279	470	141	109	-	18	23
CR 5-3	0.55	281	472	306	497	141	109	-	19	23
CR 5-4	0.55	308	499	333	524	141	109	-	19	24
CR 5-5	0.75	341	572	366	597	141	109	-	23	27
CR 5-6	1.1	368	619	393	644	141	109	-	25	30
CR 5-7	1.1	395	646	420	671	141	109	-	26	30
CR 5-8	1.1	422	673	447	698	141	109	-	26	31
CR 5-9	1.5	465	746	490	771	178	110	-	33	38
CR 5-10	1.5	492	773	517	798	178	110	-	34	39
CR 5-11	2.2	519	840	544	865	178	110	-	38	43
CR 5-12	2.2	546	867	571	892	178	110	-	39	44
CR 5-13	2.2	573	894	598	919	178	110	-	40	44
CR 5-14	2.2	600	921	625	946	178	110	-	40	45
CR 5-15	2.2	627	948	652	973	178	110	-	41	45
CR 5-16	2.2	654	975	679	1000	178	110	-	41	46
CR 5-18	3	712	1047	737	1072	198	120	-	48	52
CR 5-20	3	766	1101	791	1126	198	120	-	49	53
CR 5-22	4	820	1192	845	1217	220	134	-	62	66
CR 5-24	4	-	-	899	1271	220	134	-	-	67
CR 5-26	4	-	-	953	1325	220	134	-	-	69
CR 5-29	4	-	-	1034	1406	220	134	-	-	70
CR 5-32	5.5	-	-	1145	1536	220	134	300	-	83
CR 5-36	5.5	-	-	1253	1644	220	134	300	-	85

CRI, CRN 5

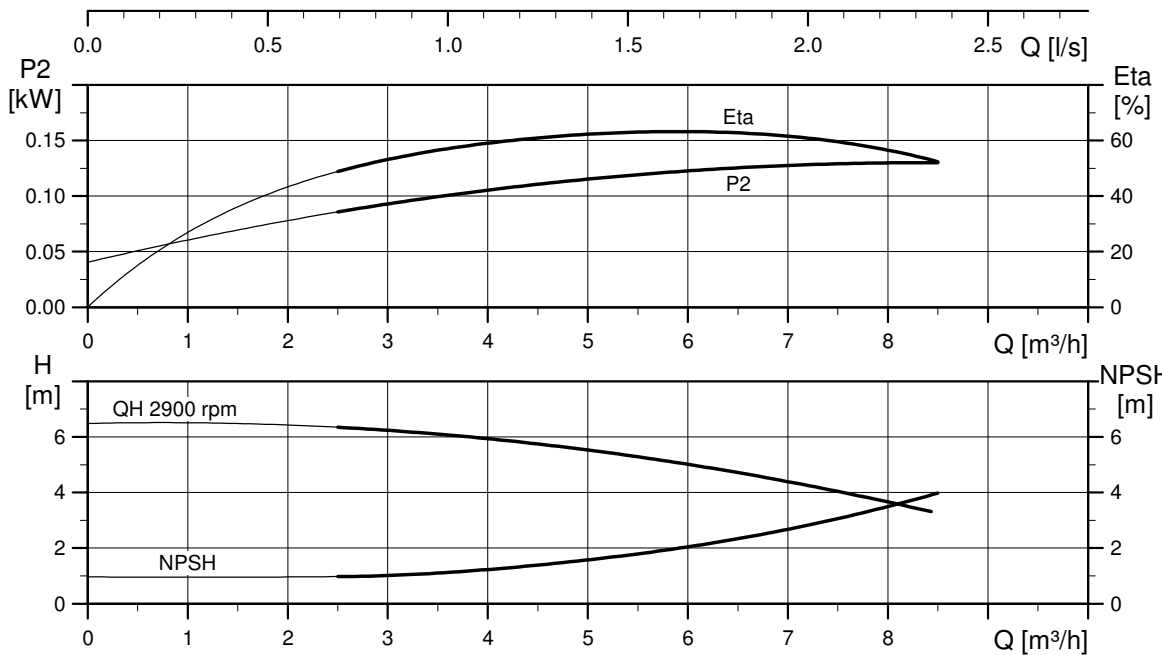
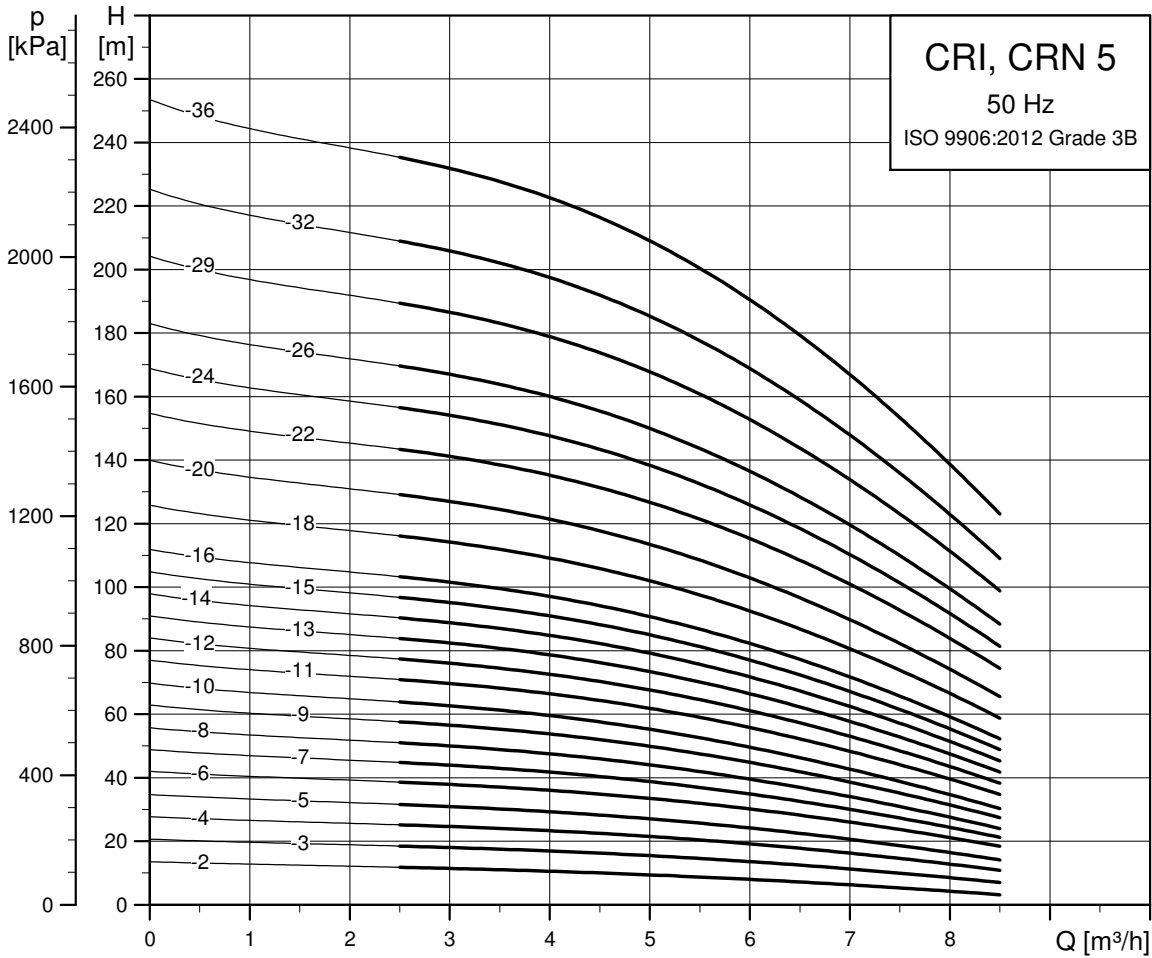

TM02 7295 0918

Dimensional sketch

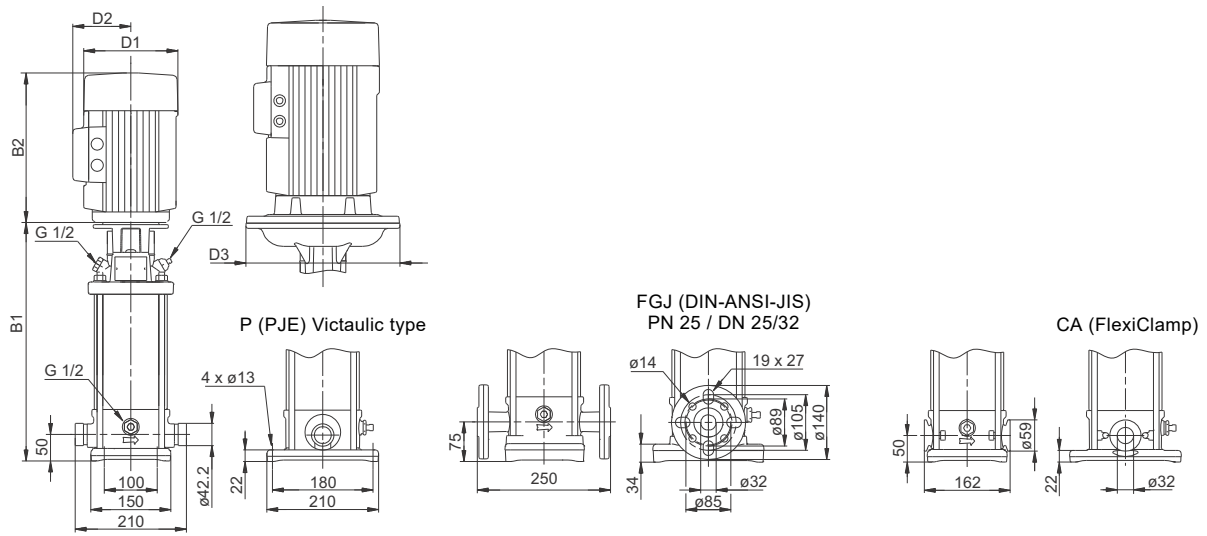

TM06 9594 2517

Dimensions and weights

Pump type	Motor P <sub>2</sub> [kW]	CRI/CRN								
		Dimension [mm]						Net weight [kg]		
		PJE/CA		DIN flange		D1	D2	D3	PJE/CA	DIN flange
B1	B1+B2	B1	B1+B2							
CRI/CRN 5-2	0.37	257	448	282	473	141	109	-	17	21
CRI/CRN 5-3	0.55	284	475	309	500	141	109	-	17	21
CRI/CRN 5-4	0.55	311	502	336	527	141	109	-	17	21
CRI/CRN 5-5	0.75	344	575	369	600	141	109	-	21	25
CRI/CRN 5-6	1.1	371	622	396	647	141	109	-	24	28
CRI/CRN 5-7	1.1	398	649	423	674	141	109	-	24	29
CRI/CRN 5-8	1.1	425	676	450	701	141	109	-	25	29
CRI/CRN 5-9	1.5	468	749	493	774	178	110	-	31	36
CRI/CRN 5-10	1.5	495	776	520	801	178	110	-	32	36
CRI/CRN 5-11	2.2	522	843	547	868	178	110	-	36	40
CRI/CRN 5-12	2.2	549	870	574	895	178	110	-	37	41
CRI/CRN 5-13	2.2	576	897	601	922	178	110	-	37	42
CRI/CRN 5-14	2.2	603	924	628	949	178	110	-	38	42
CRI/CRN 5-15	2.2	630	951	655	976	178	110	-	39	43
CRI/CRN 5-16	2.2	657	978	682	1003	178	110	-	39	43
CRI/CRN 5-18	3	716	1051	741	1076	198	120	-	46	50
CRI/CRN 5-20	3	770	1105	795	1130	198	120	-	47	51
CRI/CRN 5-22	4	824	1196	849	1221	220	134	-	60	64
CRI/CRN 5-24	4	878	1250	903	1275	220	134	-	61	65
CRI/CRN 5-26	4	932	1304	957	1329	220	134	-	62	66
CRI/CRN 5-29	4	1013	1385	1038	1410	220	134	-	64	68
CRI/CRN 5-32	5.5	1123	1514	1148	1539	220	134	300	76	80
CRI/CRN 5-36	5.5	1231	1622	1256	1647	220	134	300	78	82

CR 10

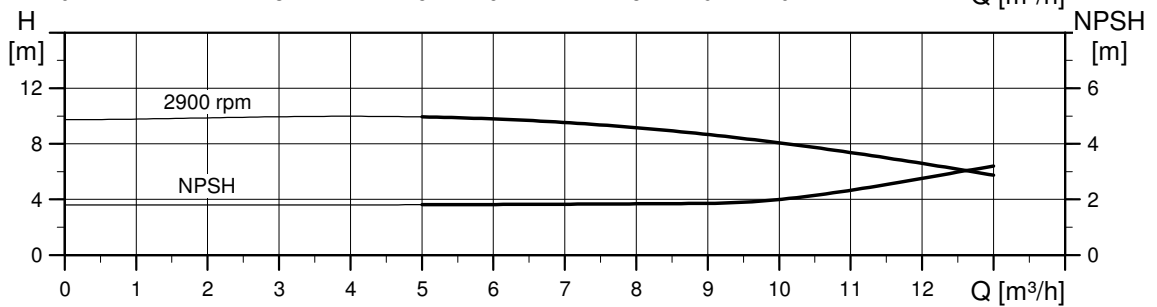
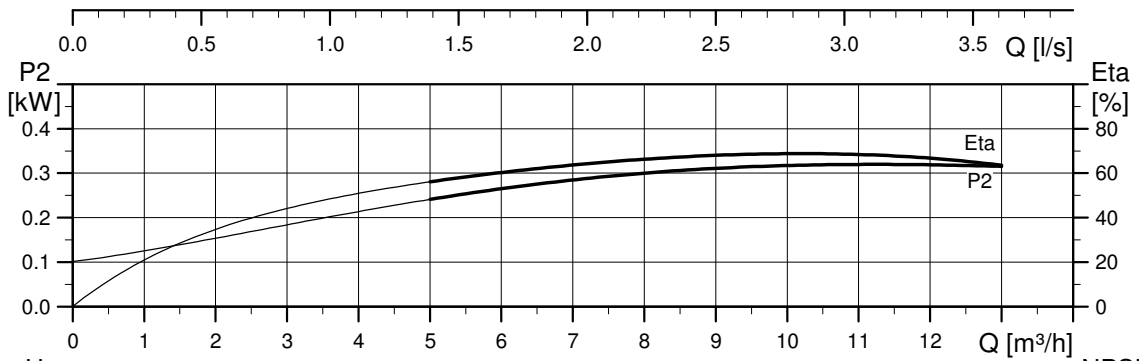
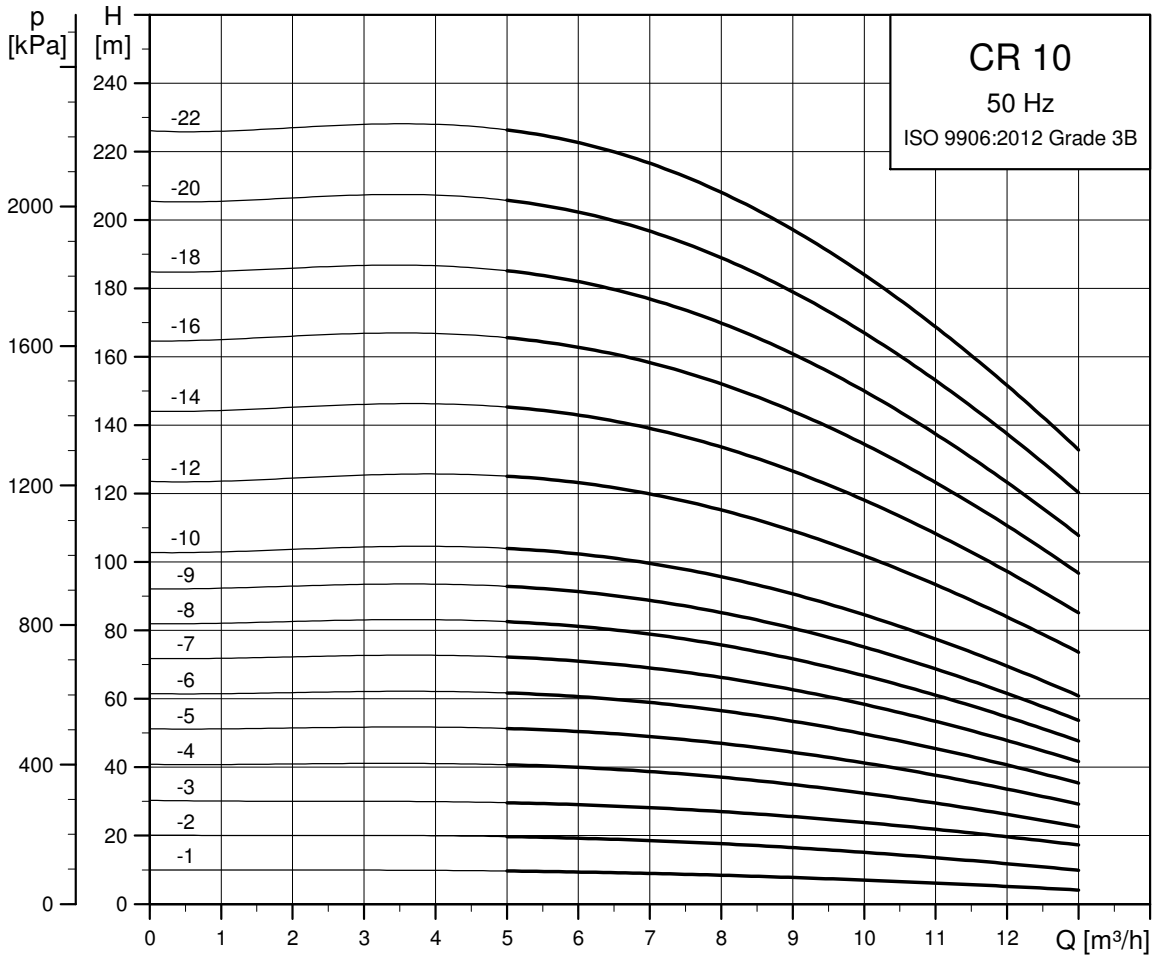

TM02 7296 0918

Dimensional sketch

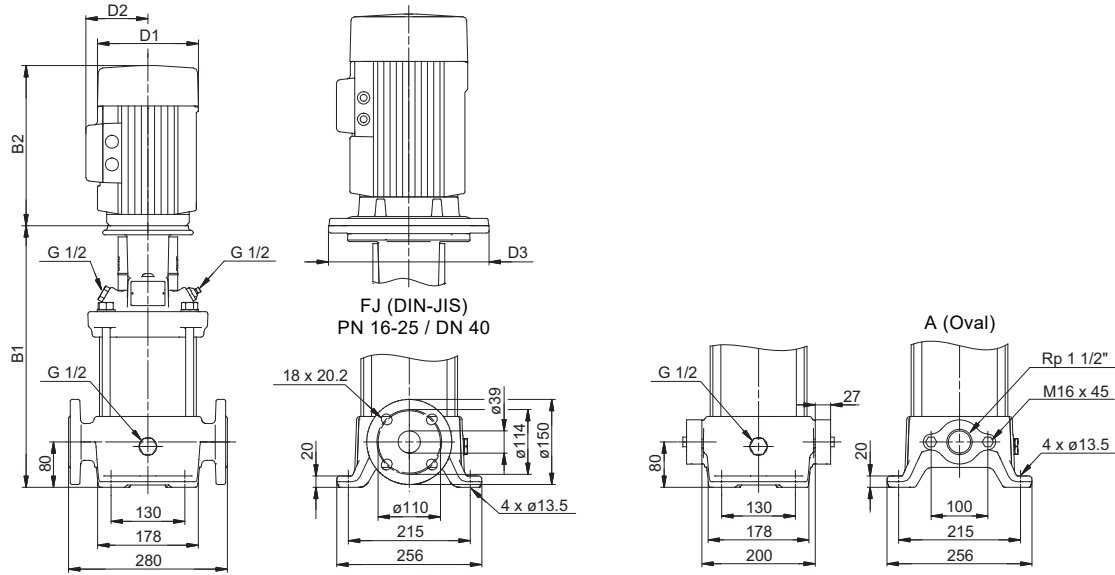

TM06 9595 2020

Dimensions and weights

Pump type	Motor P <sub>2</sub> [kW]	CR								
		Dimension [mm]						Net weight [kg]		
		Oval flange		DIN flange		D1	D2	D3	Oval flange	DIN flange
		B1	B1+B2	B1	B1+B2					
CR 10-1	0.37	343	534	343	534	141	109	-	31	34
CR 10-2	0.75	347	578	347	578	141	109	-	34	36
CR 10-3	1.1	377	628	377	628	141	109	-	37	39
CR 10-4	1.5	423	704	423	704	178	110	-	44	47
CR 10-5	2.2	453	774	453	774	178	110	-	49	52
CR 10-6	2.2	483	804	483	804	178	110	-	50	53
CR 10-7	3	518	853	518	853	198	120	-	56	59
CR 10-8	3	548	883	548	883	198	120	-	57	60
CR 10-9	3	578	913	578	913	198	120	-	58	61
CR 10-10	4	608	980	608	980	220	134	-	71	74
CR 10-12	4	668	1040	668	1040	220	134	-	73	76
CR 10-14	5.5	760	1151	760	1151	220	134	300	92	94
CR 10-16	5.5	820	1211	820	1211	220	134	300	94	97
CR 10-18	7.5	-	-	880	1259	260	159	300	-	109
CR 10-20	7.5	-	-	940	1319	260	159	300	-	112
CR 10-22	7.5	-	-	1000	1379	260	159	300	-	114

**CRI, CRN 10**

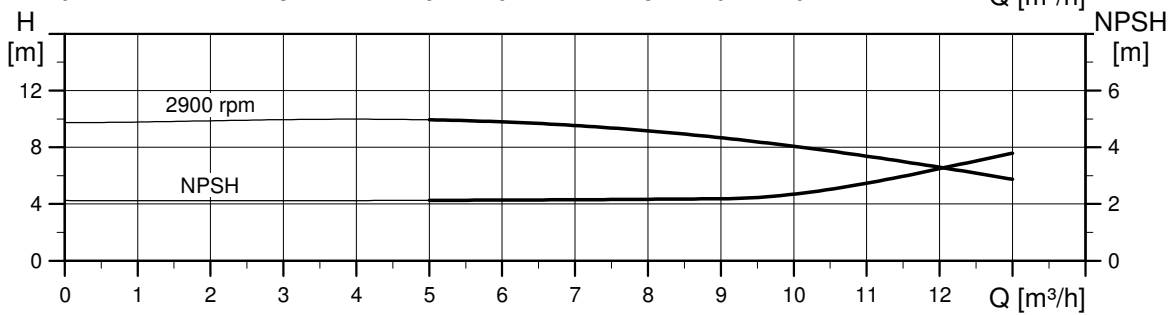
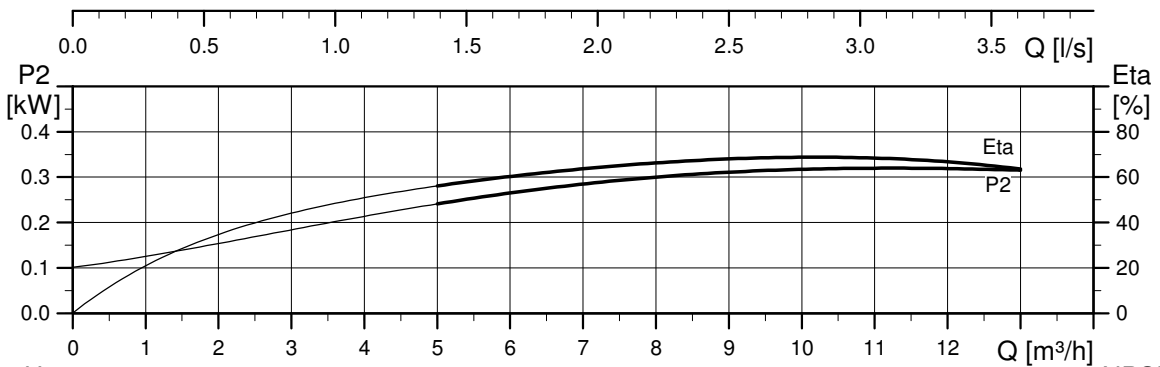
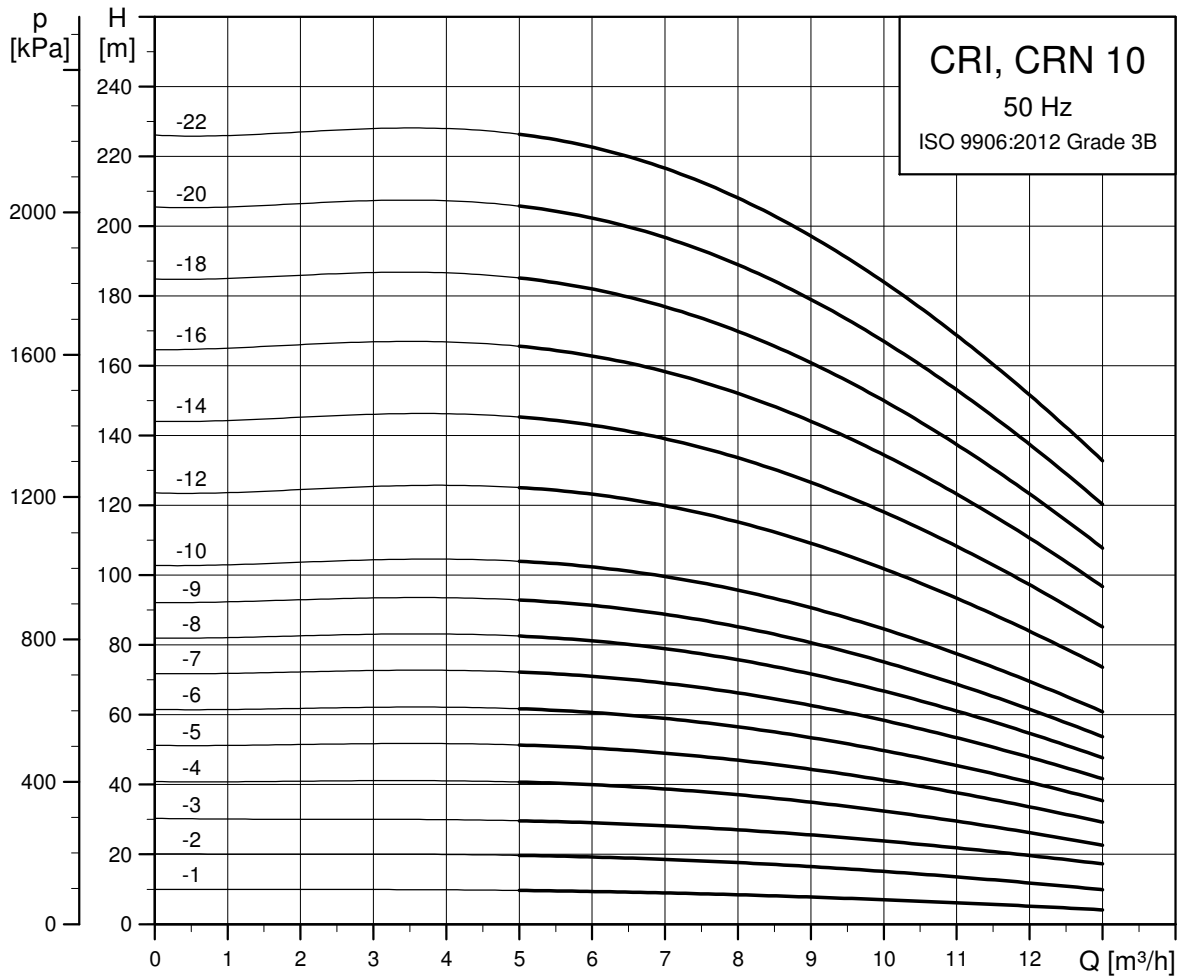

TM02 7297 0918

Dimensional sketch

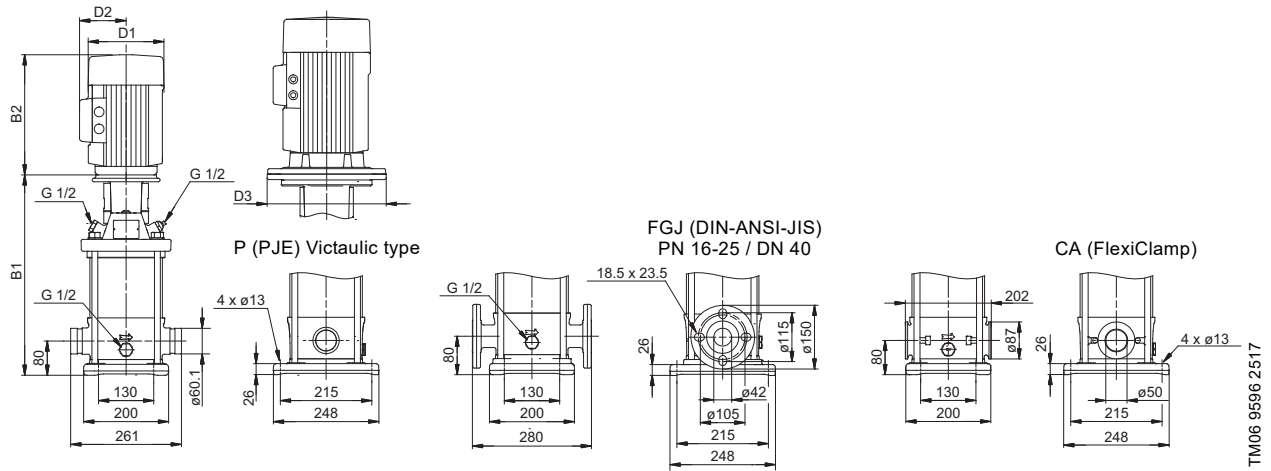

Dimensions and weights

Pump type	Motor P <sub>2</sub> [kW]	CRI/CRN								
		Dimension [mm]						Net weight [kg]		
		PJE/CA		DIN flange		D1	D2	D3	PJE/CA	DIN flange
B1	B1+B2	B1	B1+B2							
CRI/CRN 10-1	0.37	353	544	353	544	141	109	-	29	32
CRI/CRN 10-2	0.75	357	588	357	588	141	109	-	31	35
CRI/CRN 10-3	1.1	387	638	387	638	141	109	-	34	38
CRI/CRN 10-4	1.5	433	714	433	714	178	110	-	42	45
CRI/CRN 10-5	2.2	463	784	463	784	178	110	-	47	50
CRI/CRN 10-6	2.2	493	814	493	814	178	110	-	48	51
CRI/CRN 10-7	3	528	863	528	863	198	120	-	54	58
CRI/CRN 10-8	3	558	893	558	893	198	120	-	55	59
CRI/CRN 10-9	3	588	923	588	923	198	120	-	56	60
CRI/CRN 10-10	4	618	990	618	990	220	134	-	69	73
CRI/CRN 10-12	4	678	1050	678	1050	220	134	-	71	75
CRI/CRN 10-14	5.5	770	1161	770	1161	220	134	300	90	94
CRI/CRN 10-16	5.5	830	1221	830	1221	220	134	300	92	96
CRI/CRN 10-18	7.5	890	1269	890	1269	260	159	300	104	108
CRI/CRN 10-20	7.5	950	1329	950	1329	260	159	300	106	110
CRI/CRN 10-22	7.5	1010	1389	1010	1389	260	159	300	108	112

CR 15

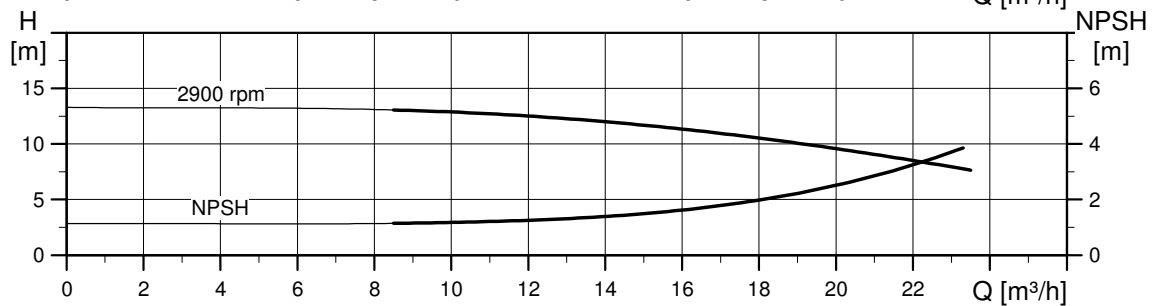
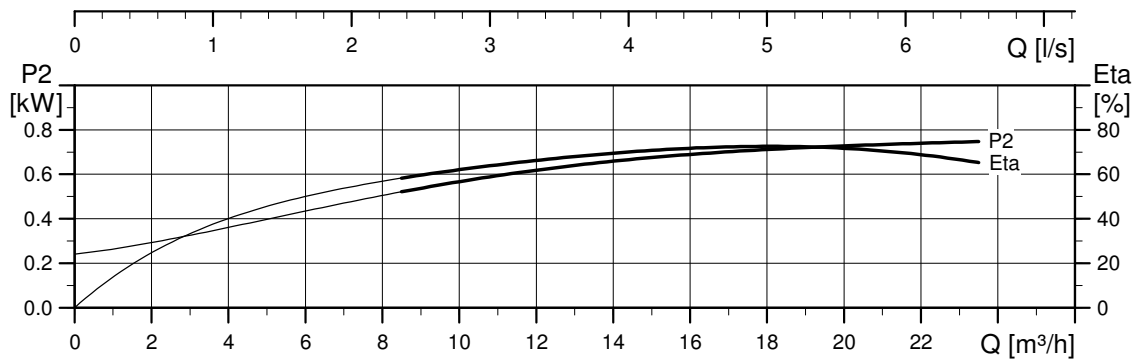
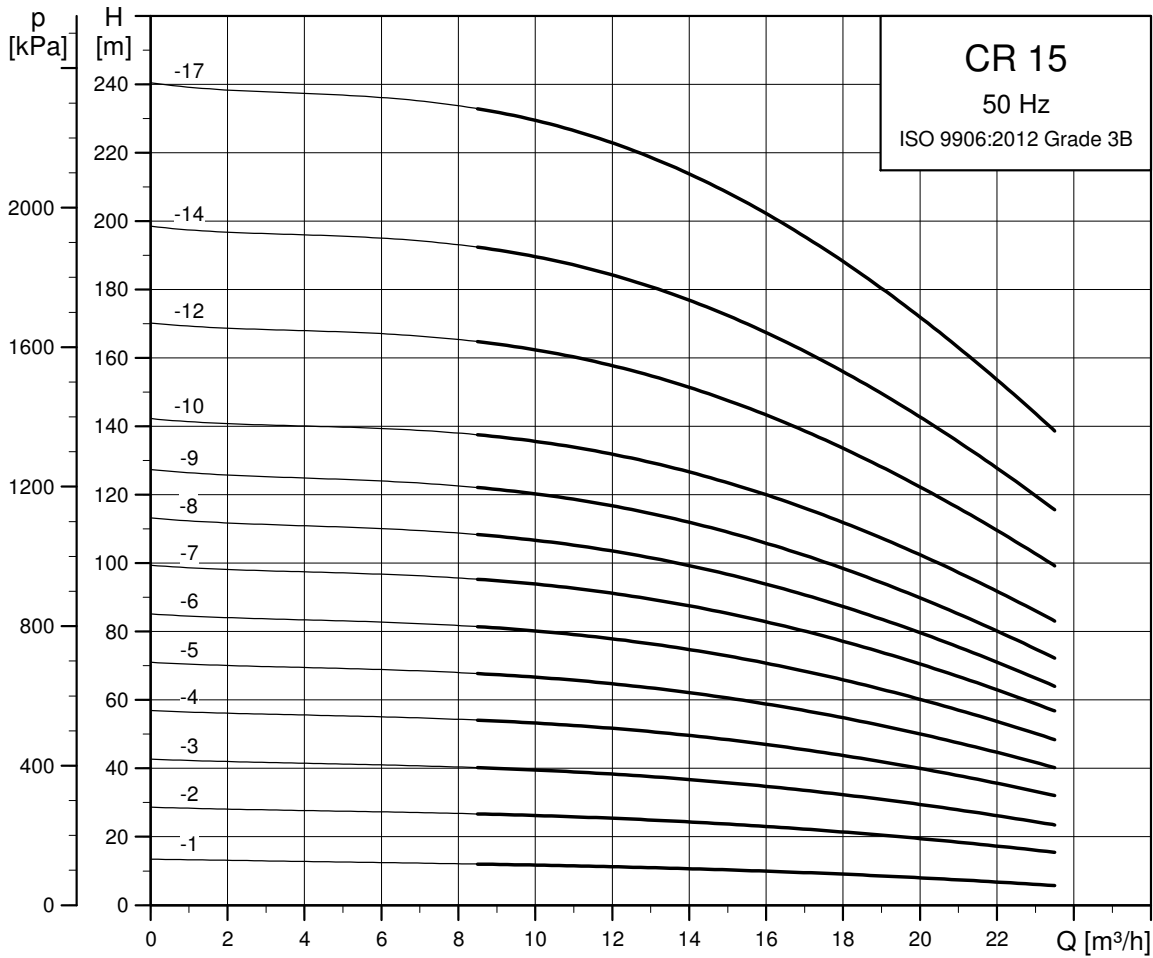

TM02 7296 0918

Dimensional sketch

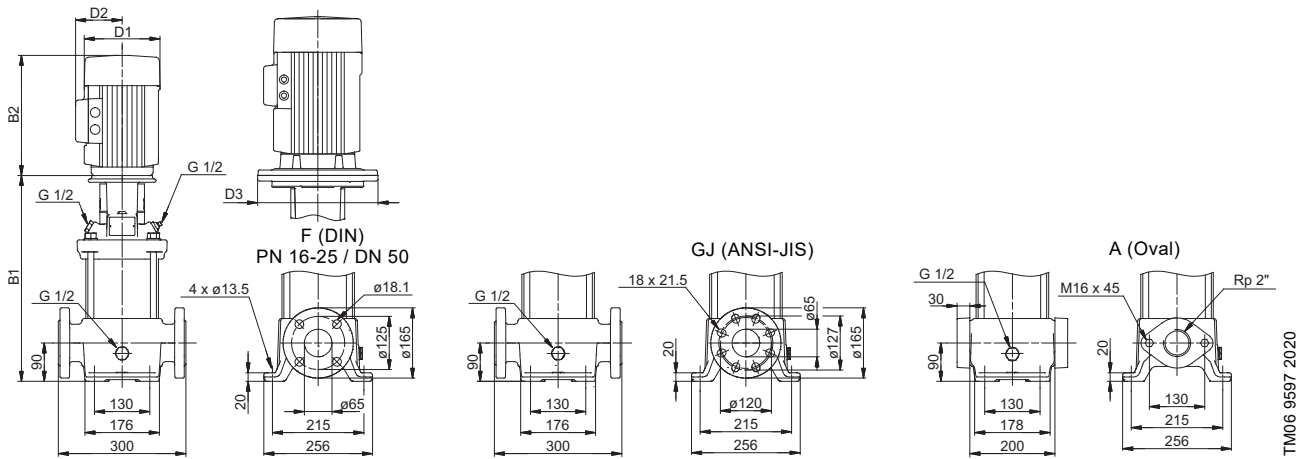

Dimensions and weights

Pump type	Motor P <sub>2</sub> [kW]	CR								
		Dimension [mm]						Net weight [kg]		
		Oval flange		DIN flange		D1	D2	D3	Oval flange	DIN flange
		B1	B1+B2	B1	B1+B2					
CR 15-1	1.1	400	651	400	651	141	109	-	41	42
CR 15-2	2.2	415	736	415	736	178	110	-	52	53
CR 15-3	3	465	800	465	800	198	120	-	58	59
CR 15-4	4	510	882	510	882	220	134	-	71	72
CR 15-5	4	555	927	555	927	220	134	-	73	74
CR 15-6	5.5	632	1023	632	1023	220	134	300	91	92
CR 15-7	5.5	677	1068	677	1068	220	134	300	93	94
CR 15-8	7.5	-	-	722	1101	260	159	300	-	105
CR 15-9	7.5	-	-	767	1146	260	159	300	-	107
CR 15-10	11	-	-	889	1371	318	204	350	-	149
CR 15-12	11	-	-	979	1461	318	204	350	-	153
CR 15-14	11	-	-	1069	1551	318	204	350	-	157
CR 15-17	15	-	-	1204	1686	318	204	350	-	174

**CRI, CRN 15**

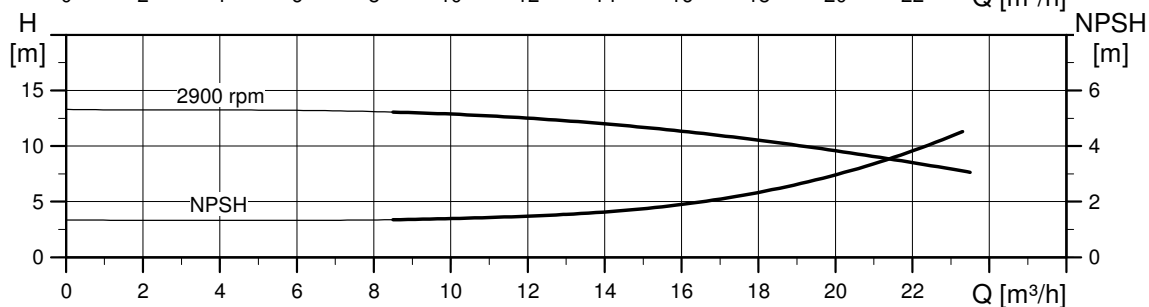
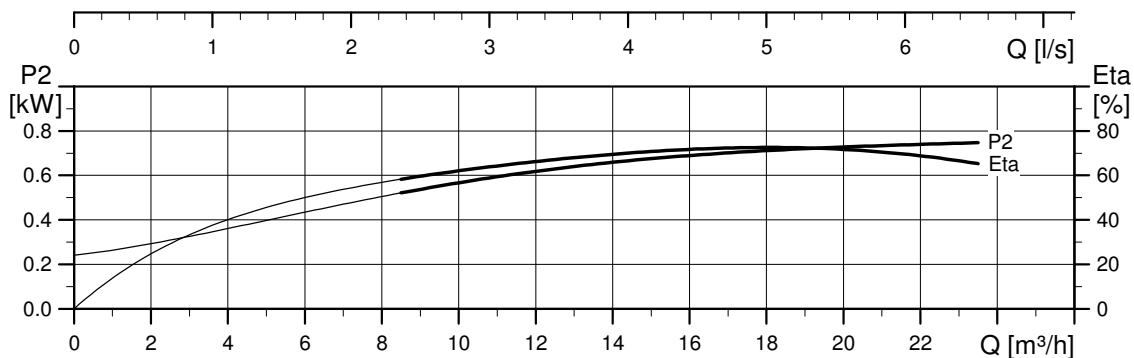
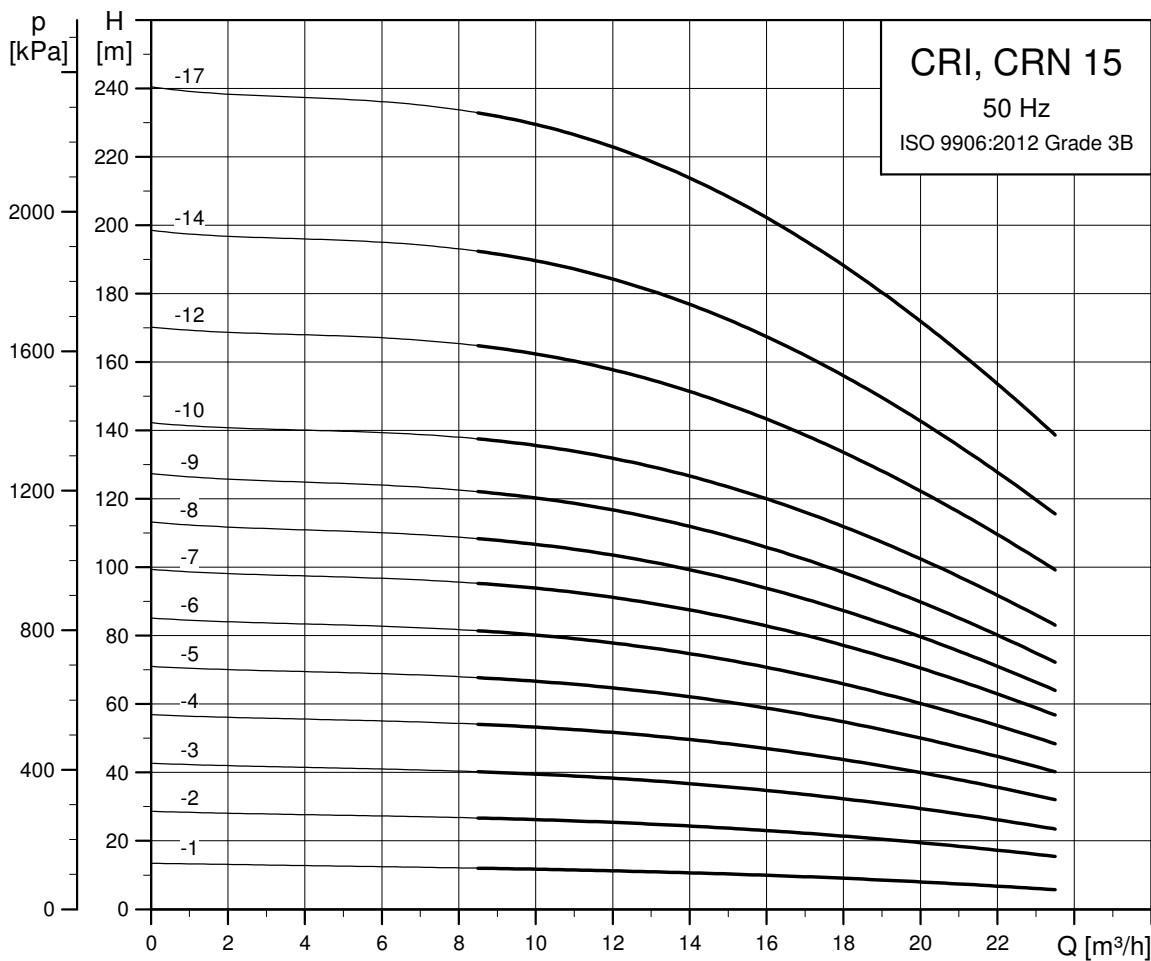

TM02 7299 0918

Dimensional sketch

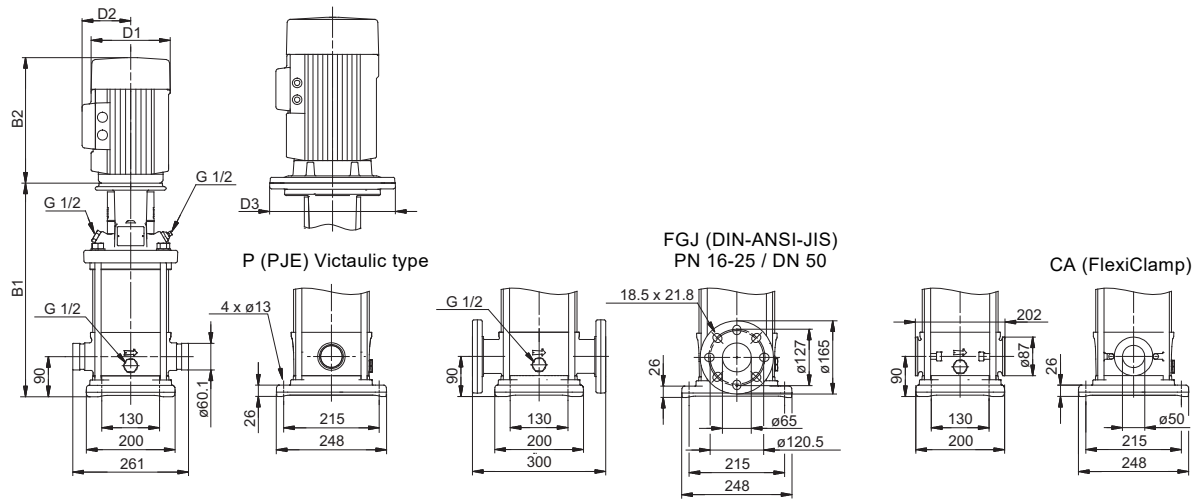

TM06 9598 2517

Dimensions and weights

Pump type	Motor P <sub>2</sub> [kW]	CRI/CRN							Net weight [kg]	
		Dimension [mm]				D1	D2	D3	PJE/CA	DIN flange
		PJE/CA		DIN flange						
B1	B1+B2	B1	B1+B2							
CRI/CRN 15-1	1.1	397	648	397	648	141	109	-	34	39
CRI/CRN 15-2	2.2	413	734	413	734	178	110	-	45	50
CRI/CRN 15-3	3	463	798	463	798	198	120	-	52	56
CRI/CRN 15-4	4	508	880	508	880	220	134	-	65	70
CRI/CRN 15-5	4	553	925	553	925	220	134	-	67	71
CRI/CRN 15-6	5.5	630	1021	630	1021	220	134	300	85	89
CRI/CRN 15-7	5.5	675	1066	675	1066	220	134	300	86	91
CRI/CRN 15-8	7.5	720	1099	720	1099	260	159	300	98	103
CRI/CRN 15-9	7.5	765	1144	765	1144	260	159	300	100	104
CRI/CRN 15-10	11	887	1369	887	1369	318	204	350	142	147
CRI/CRN 15-12	11	977	1459	977	1459	318	204	350	145	150
CRI/CRN 15-14	11	1067	1549	1067	1549	318	204	350	149	153
CRI/CRN 15-17	15	1202	1684	1202	1684	318	204	350	165	170

CR 20

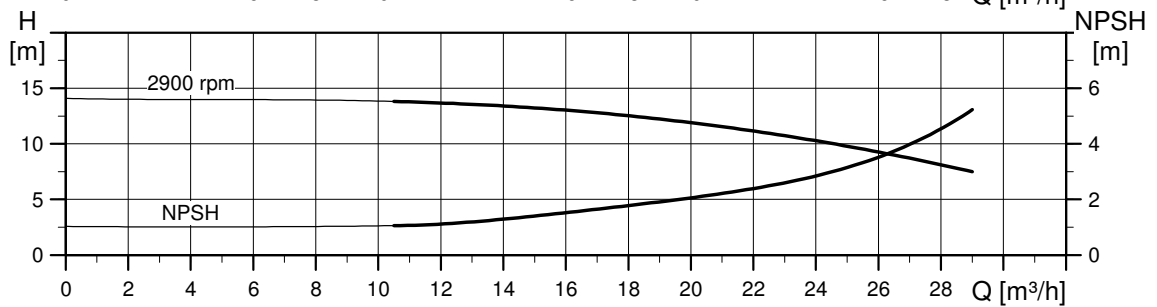
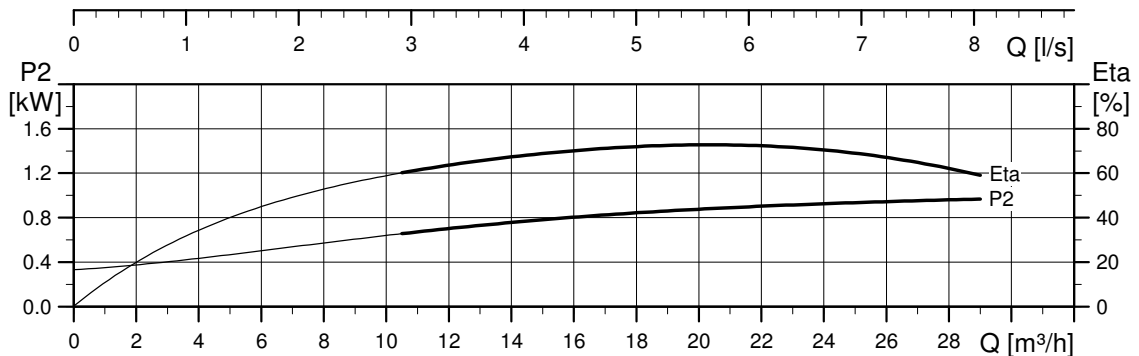
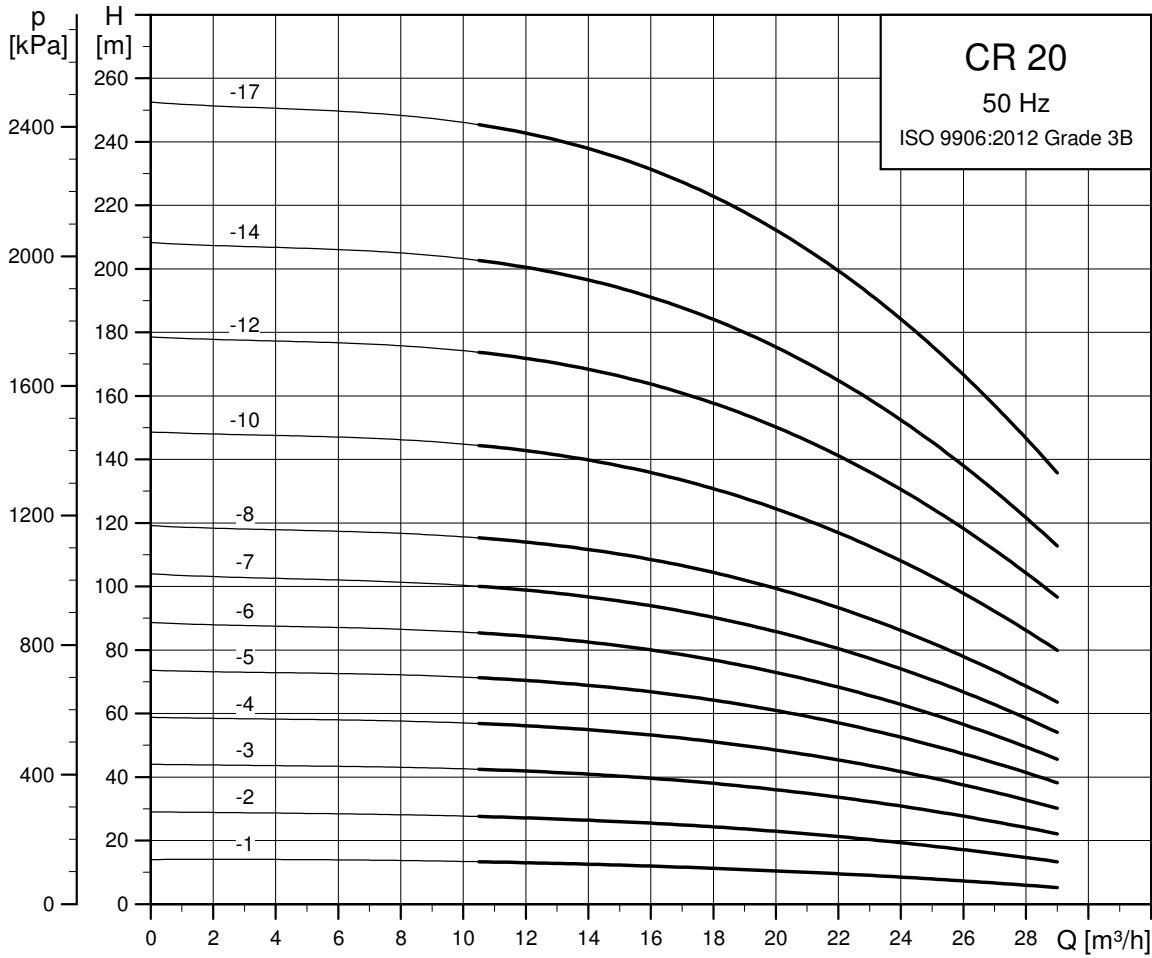

TM02 7300 0918

Dimensional sketch

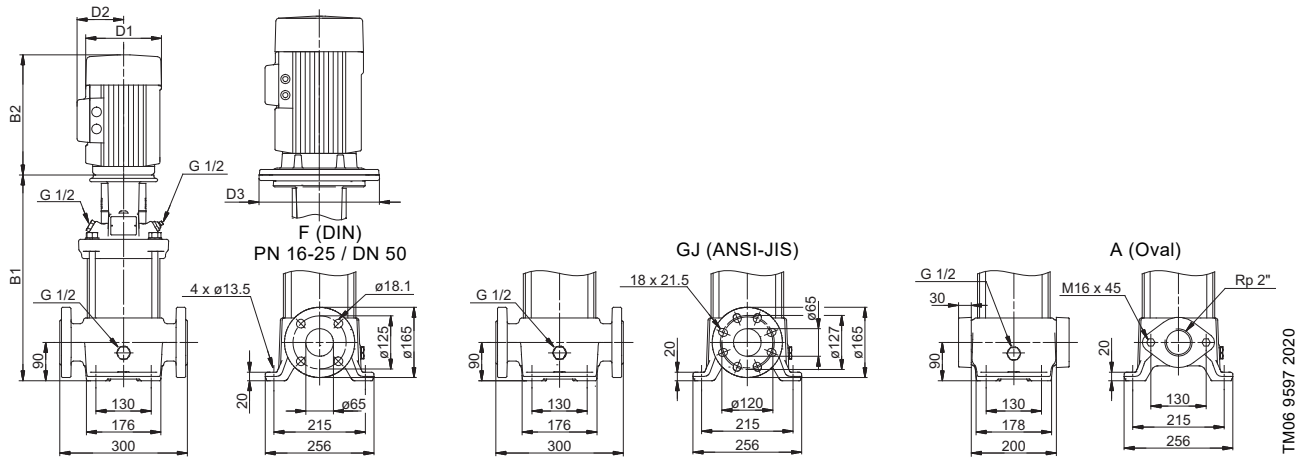

TM06 9597 2020

Dimensions and weights

Pump type	Motor P <sub>2</sub> [kW]	CR								
		Dimension [mm]						Net weight [kg]		
		Oval flange		DIN flange		D1	D2	D3	Oval flange	DIN flange
		B1	B1+B2	B1	B1+B2					
CR 20-1	1.1	400	651	400	651	141	109	-	41	42
CR 20-2	2.2	415	736	415	736	178	110	-	52	53
CR 20-3	4	465	837	465	837	220	134	-	70	71
CR 20-4	5.5	542	933	542	933	220	134	300	88	89
CR 20-5	5.5	587	978	587	978	220	134	300	90	90
CR 20-6	7.5	632	1011	632	1011	260	159	300	101	102
CR 20-7	7.5	677	1056	677	1056	260	159	300	103	103
CR 20-8	11	-	-	799	1281	318	204	350	-	146
CR 20-10	11	-	-	889	1371	318	204	350	-	149
CR 20-12	15	-	-	979	1461	318	204	350	-	165
CR 20-14	15	-	-	1069	1551	318	204	350	-	169
CR 20-17	18.5	-	-	1204	1730	318	204	350	-	186

**CRI, CRN 20**

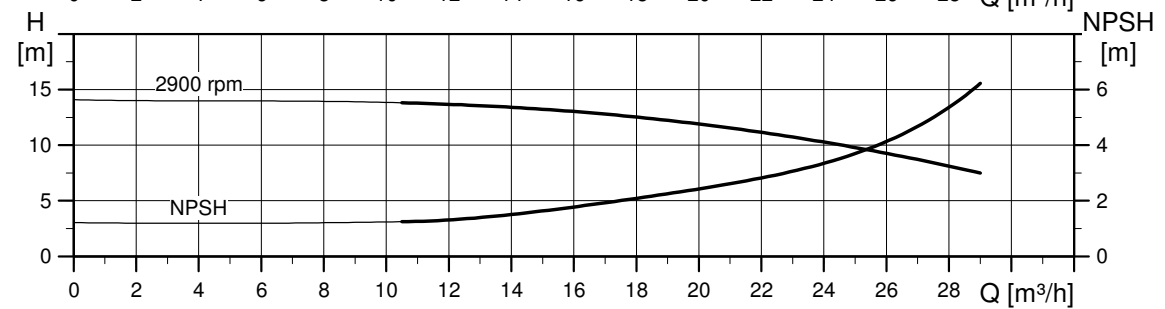
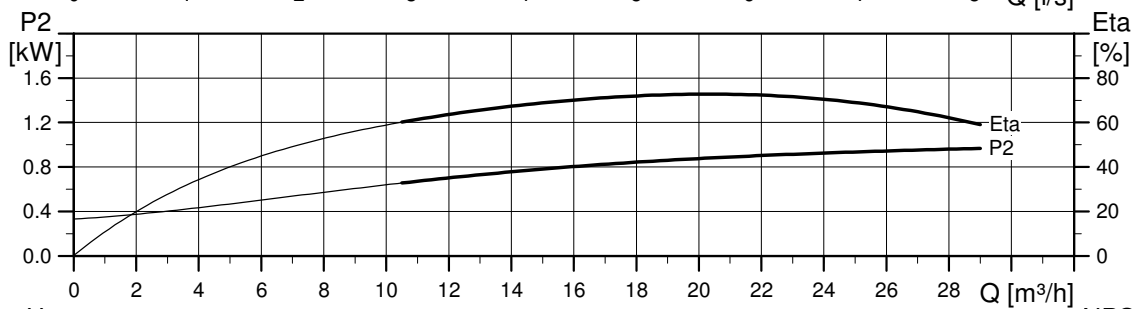
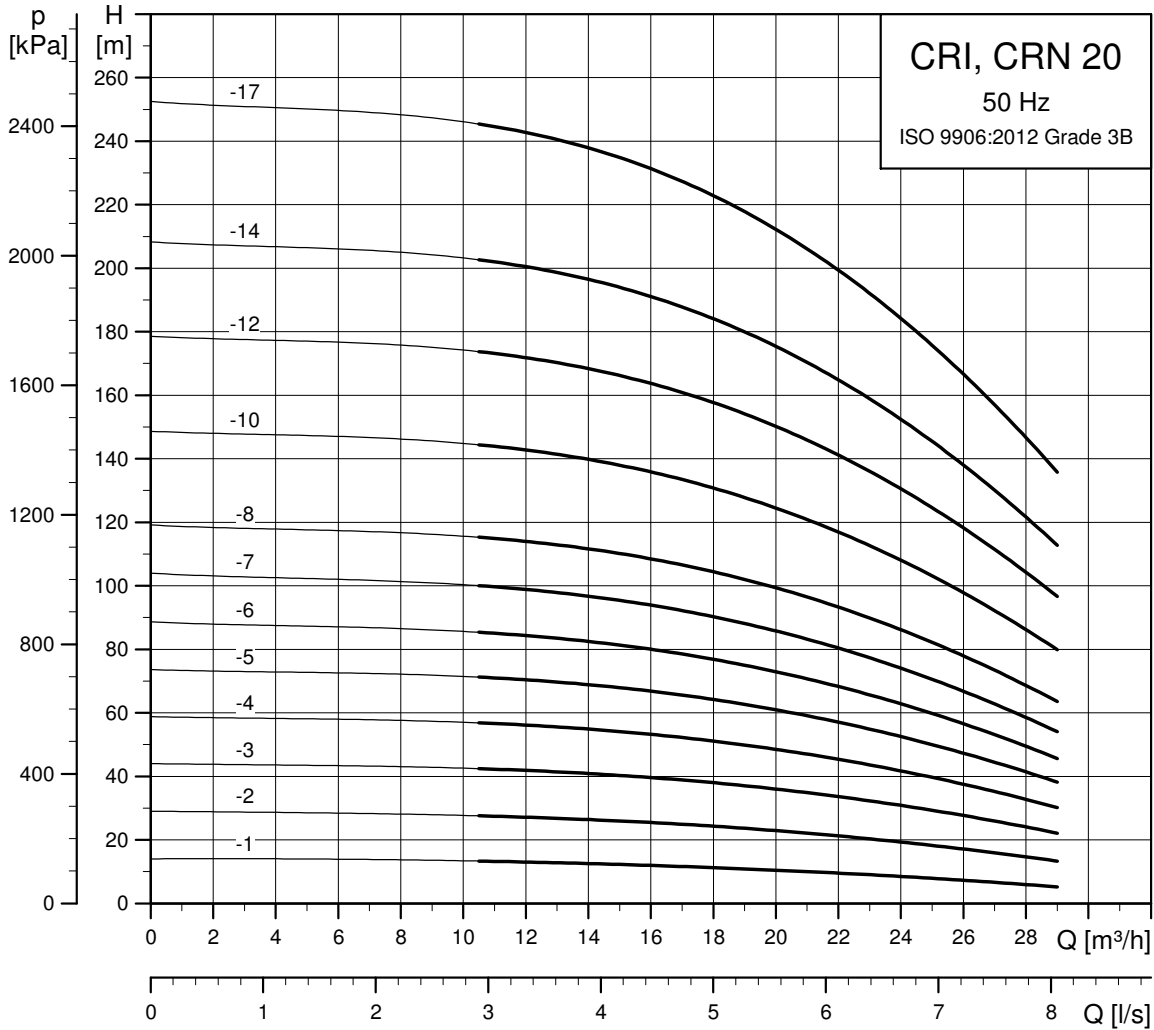

TM02 7301 0918

**Dimensional sketch**

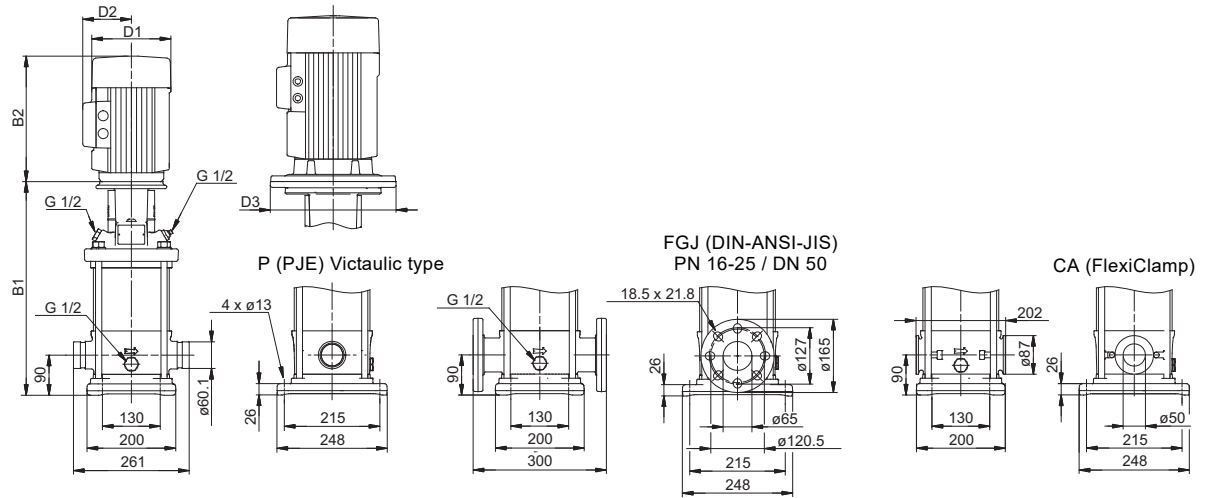

TM06 9598 2517

**Dimensions and weights**

Pump type	Motor P <sub>2</sub> [kW]	CRI/CRN								
		Dimension [mm]						Net weight [kg]		
		PJE/CA		DIN flange		D1	D2	D3	PJE/CA	DIN flange
B1	B1+B2	B1	B1+B2							
CRI/CRN 20-1	1.1	397	648	397	648	141	109	-	34	39
CRI/CRN 20-2	2.2	413	734	413	734	178	110	-	45	50
CRI/CRN 20-3	4	463	835	463	835	220	134	-	63	68
CRI/CRN 20-4	5.5	540	931	540	931	220	134	300	82	86
CRI/CRN 20-5	5.5	585	976	585	976	220	134	300	83	88
CRI/CRN 20-6	7.5	630	1009	630	1009	260	159	300	94	99
CRI/CRN 20-7	7.5	675	1054	675	1054	260	159	300	96	101
CRI/CRN 20-8	11	797	1279	797	1279	318	204	350	138	143
CRI/CRN 20-10	11	887	1369	887	1369	318	204	350	142	147
CRI/CRN 20-12	15	977	1459	977	1459	318	204	350	157	162
CRI/CRN 20-14	15	1067	1549	1067	1549	318	204	350	161	165
CRI/CRN 20-17	18.5	1202	1728	1202	1728	318	204	350	178	183

CR 32

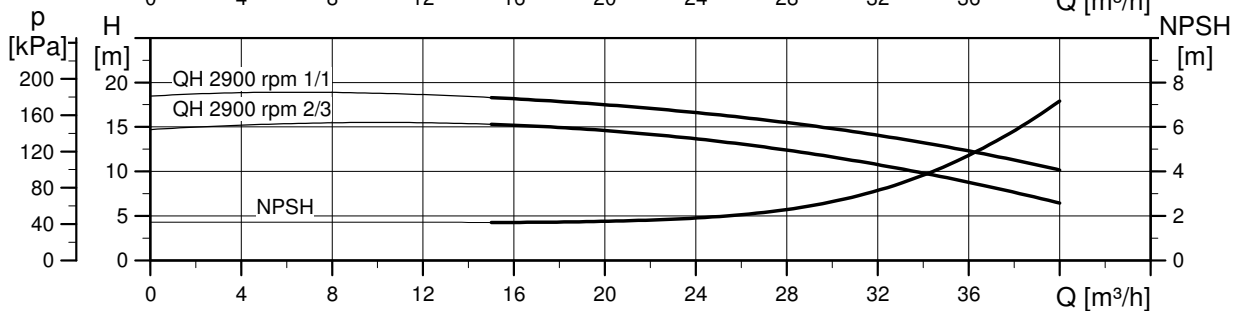
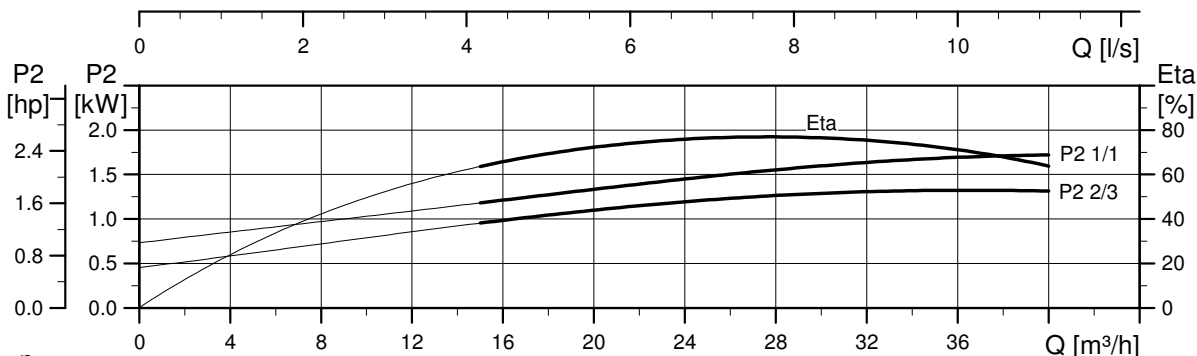
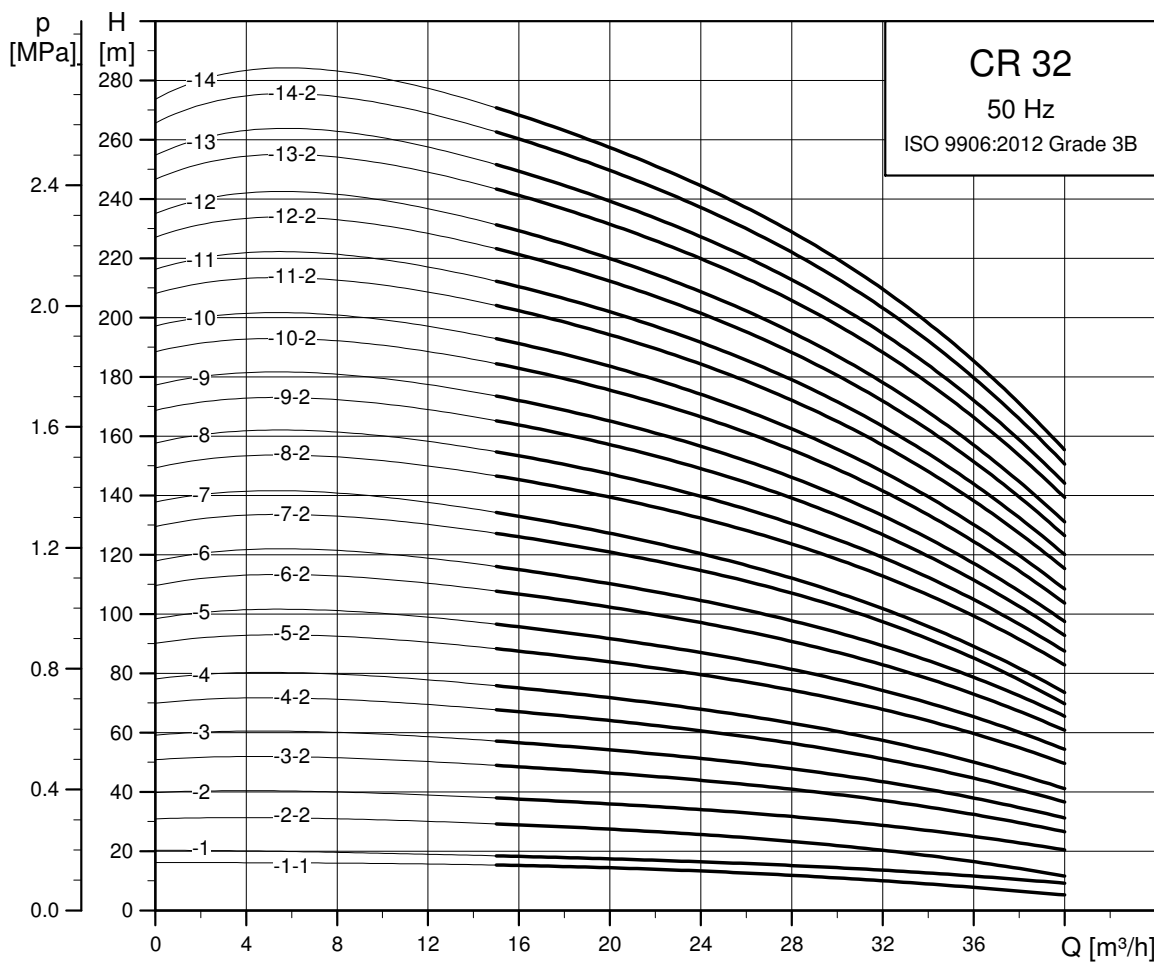

TM02 7302 0918

## Dimensional sketch

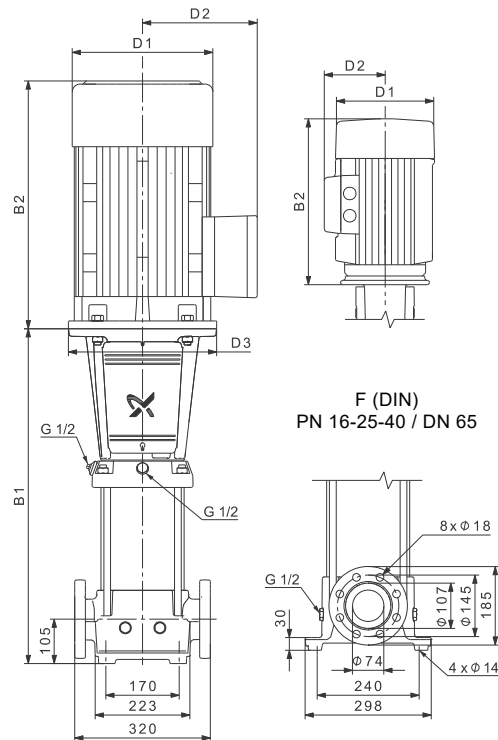

TM06 9605 2517

## Dimensions and weights

Pump type	Motor P <sub>2</sub> [kW]	CR					Net weight [kg]
		Dimension [mm]					
		B1	B1+B2	D1	D2	D3	
CR 32-1-1	1.5	505	786	178	110	-	63
CR 32-1	2.2	505	826	178	110	-	67
CR 32-2-2	3	575	910	198	120	-	75
CR 32-2	4	575	947	220	134	-	86
CR 32-3-2	5.5	645	1036	220	134	300	97
CR 32-3	5.5	645	1036	220	134	300	97
CR 32-4-2	7.5	715	1094	260	159	300	110
CR 32-4	7.5	715	1094	260	159	300	110
CR 32-5-2	11	895	1377	318	204	350	158
CR 32-5	11	895	1377	318	204	350	158
CR 32-6-2	11	965	1447	318	204	350	161
CR 32-6	11	965	1447	318	204	350	161
CR 32-7-2	15	1035	1517	318	204	350	176
CR 32-7	15	1035	1517	318	204	350	176
CR 32-8-2	15	1105	1587	318	204	350	182
CR 32-8	15	1105	1587	318	204	350	182
CR 32-9-2	18.5	1175	1701	318	204	350	198
CR 32-9	18.5	1175	1701	318	204	350	198
CR 32-10-2	18.5	1245	1771	318	204	350	201
CR 32-10	18.5	1245	1771	318	204	350	201
CR 32-11-2	22	1315	1867	318	204	350	220
CR 32-11	22	1315	1867	318	204	350	220
CR 32-12-2	22	1385	1937	318	204	350	223
CR 32-12	22	1385	1937	318	204	350	223
CR 32-13-2	30	1455	2066	396	315	400	329
CR 32-13	30	1455	2066	396	315	400	329
CR 32-14-2	30	1525	2136	396	315	400	332
CR 32-14	30	1525	2136	396	315	400	332

CRN 32

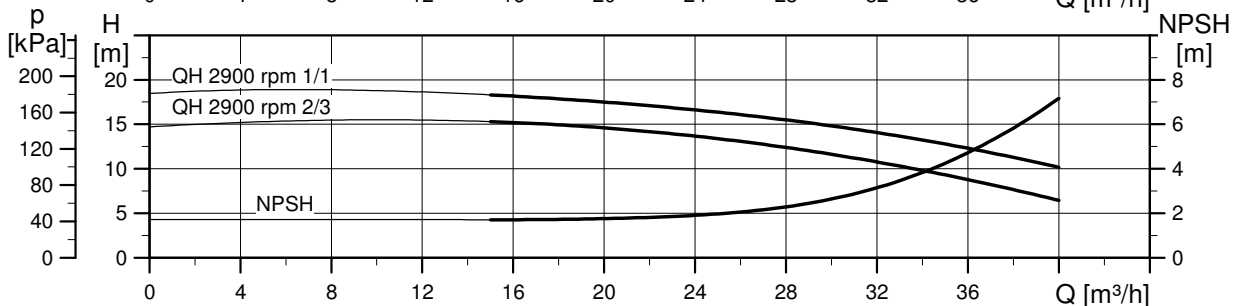
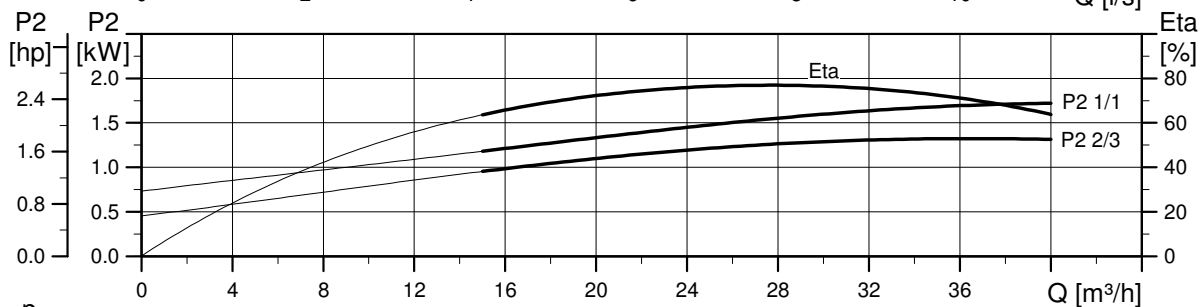
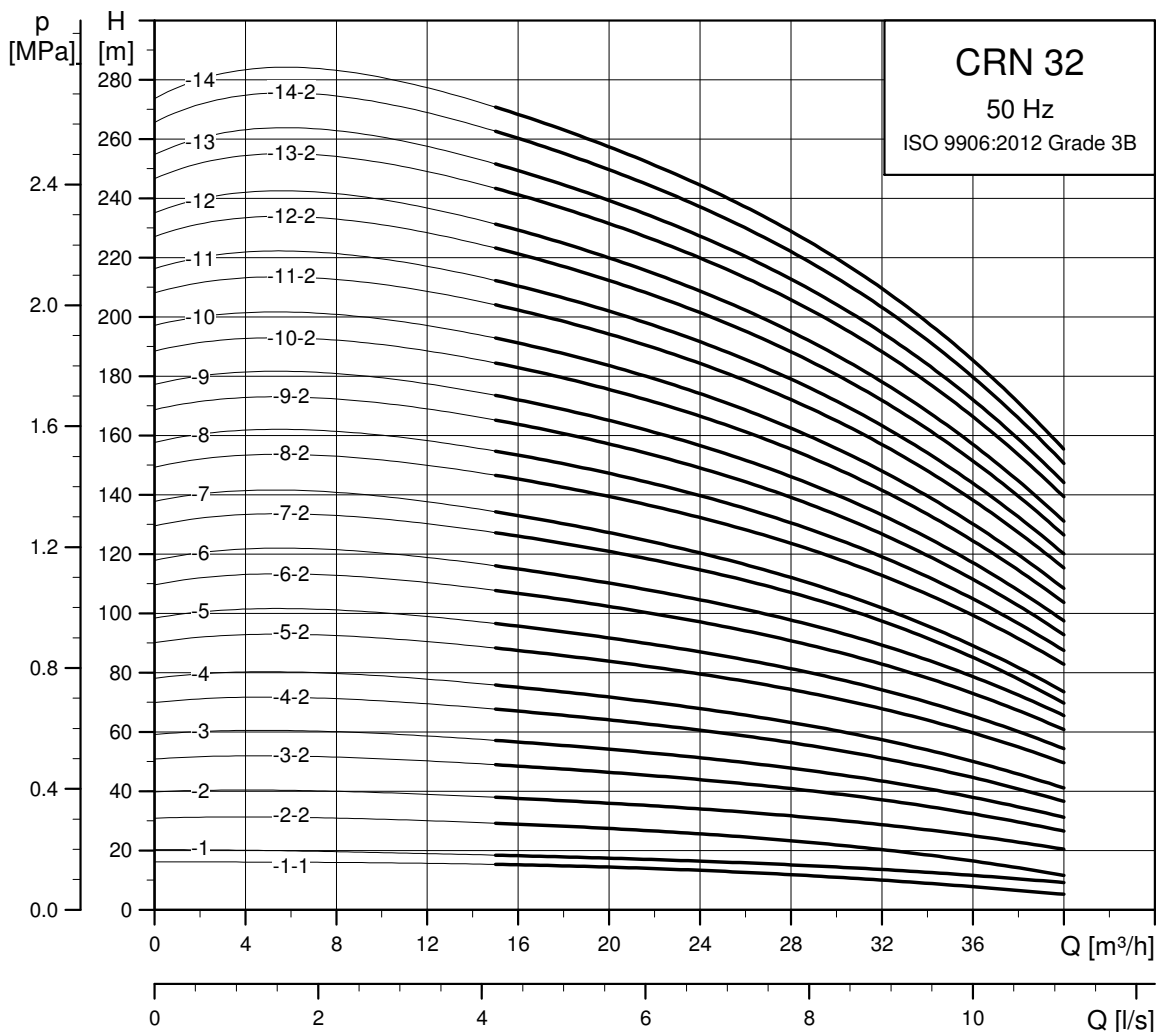

TM02 7303 0918

Dimensional sketch

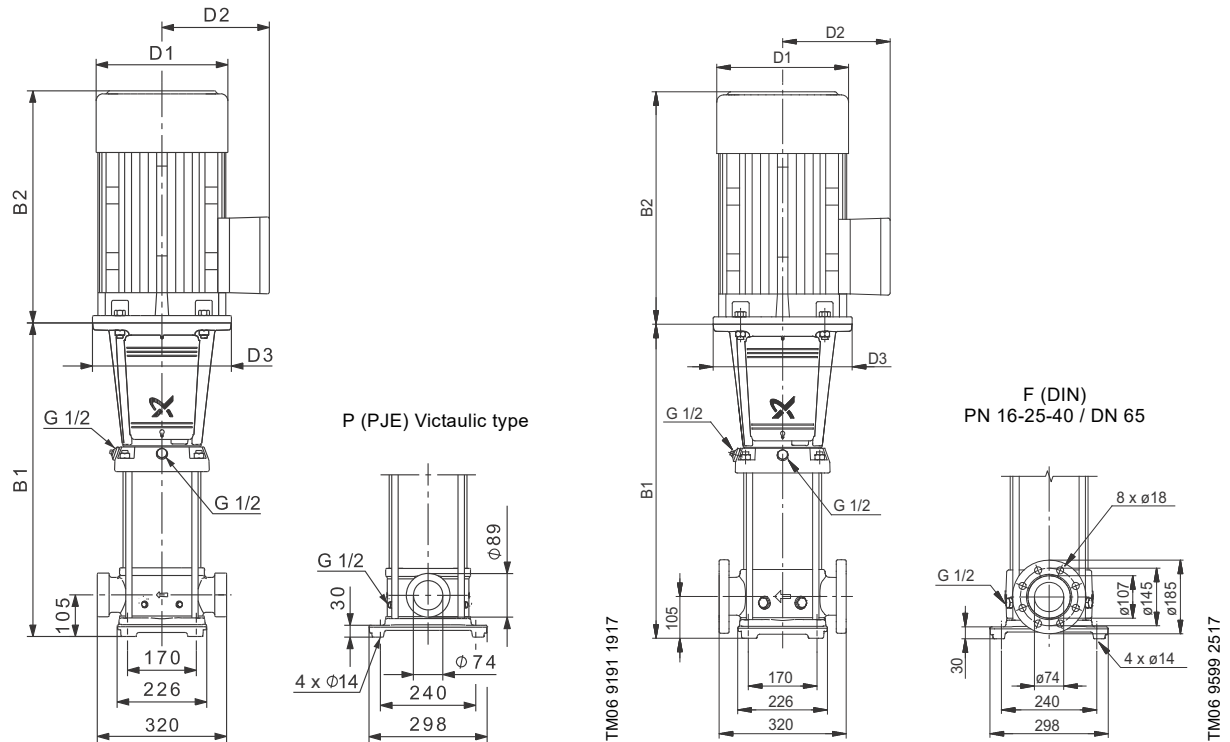

Dimensions and weights

Pump type	Motor P <sub>2</sub> [kW]	CRN					Net weight [kg]
		Dimension [mm]					
		B1	B1+B2	D1	D2	D3	
CRN 32-1-1	1.5	505	786	178	110	-	65
CRN 32-1	2.2	505	826	178	110	-	69
CRN 32-2-2	3	575	910	198	120	-	77
CRN 32-2	4	575	947	220	134	-	89
CRN 32-3-2	5.5	645	1036	220	134	300	99
CRN 32-3	5.5	645	1036	220	134	300	99
CRN 32-4-2	7.5	715	1094	260	159	300	112
CRN 32-4	7.5	715	1094	260	159	300	112
CRN 32-5-2	11	895	1377	318	204	350	160
CRN 32-5	11	895	1377	318	204	350	160
CRN 32-6-2	11	965	1447	318	204	350	163
CRN 32-6	11	965	1447	318	204	350	163
CRN 32-7-2	15	1035	1517	318	204	350	178
CRN 32-7	15	1035	1517	318	204	350	178
CRN 32-8-2	15	1105	1587	318	204	350	184
CRN 32-8	15	1105	1587	318	204	350	184
CRN 32-9-2	18.5	1175	1701	318	204	350	200
CRN 32-9	18.5	1175	1701	318	204	350	200
CRN 32-10-2	18.5	1245	1771	318	204	350	204
CRN 32-10	18.5	1245	1771	318	204	350	204
CRN 32-11-2	22	1315	1867	318	204	350	222
CRN 32-11	22	1315	1867	318	204	350	222
CRN 32-12-2	22	1385	1937	318	204	350	225
CRN 32-12	22	1385	1937	318	204	350	225
CRN 32-13-2	30	1455	2066	396	315	400	331
CRN 32-13	30	1455	2066	396	315	400	331
CRN 32-14-2	30	1525	2136	396	315	400	335
CRN 32-14	30	1525	2136	396	315	400	335

CR 45

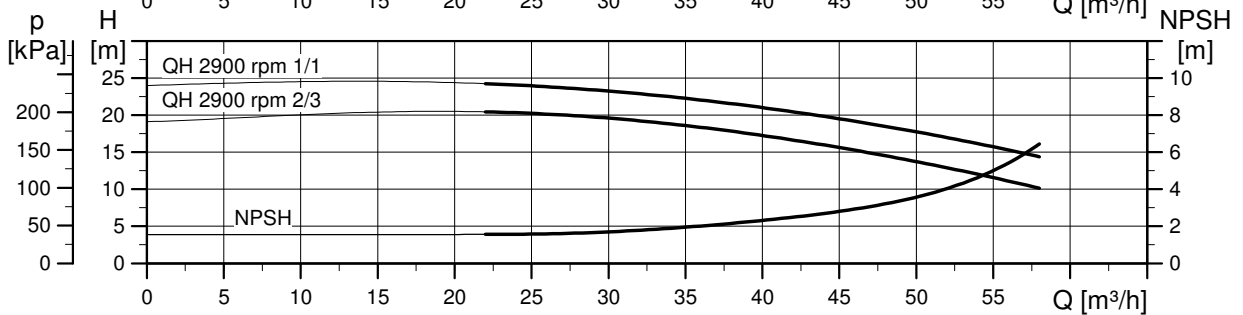
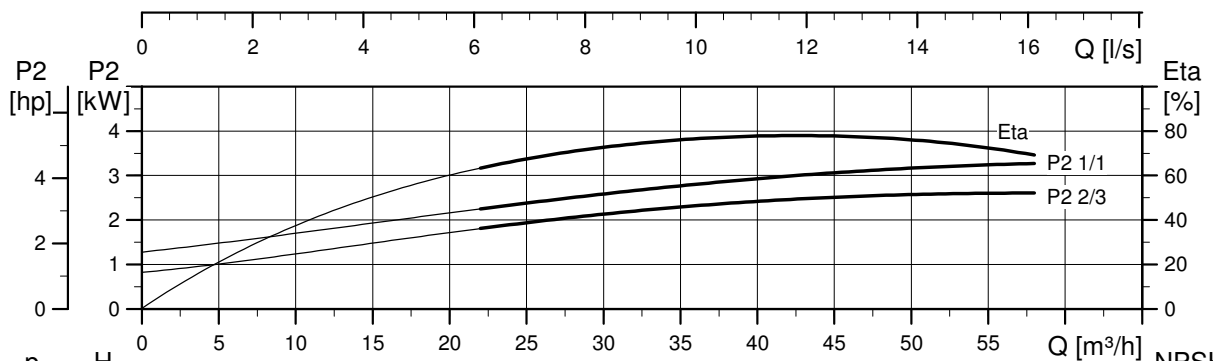
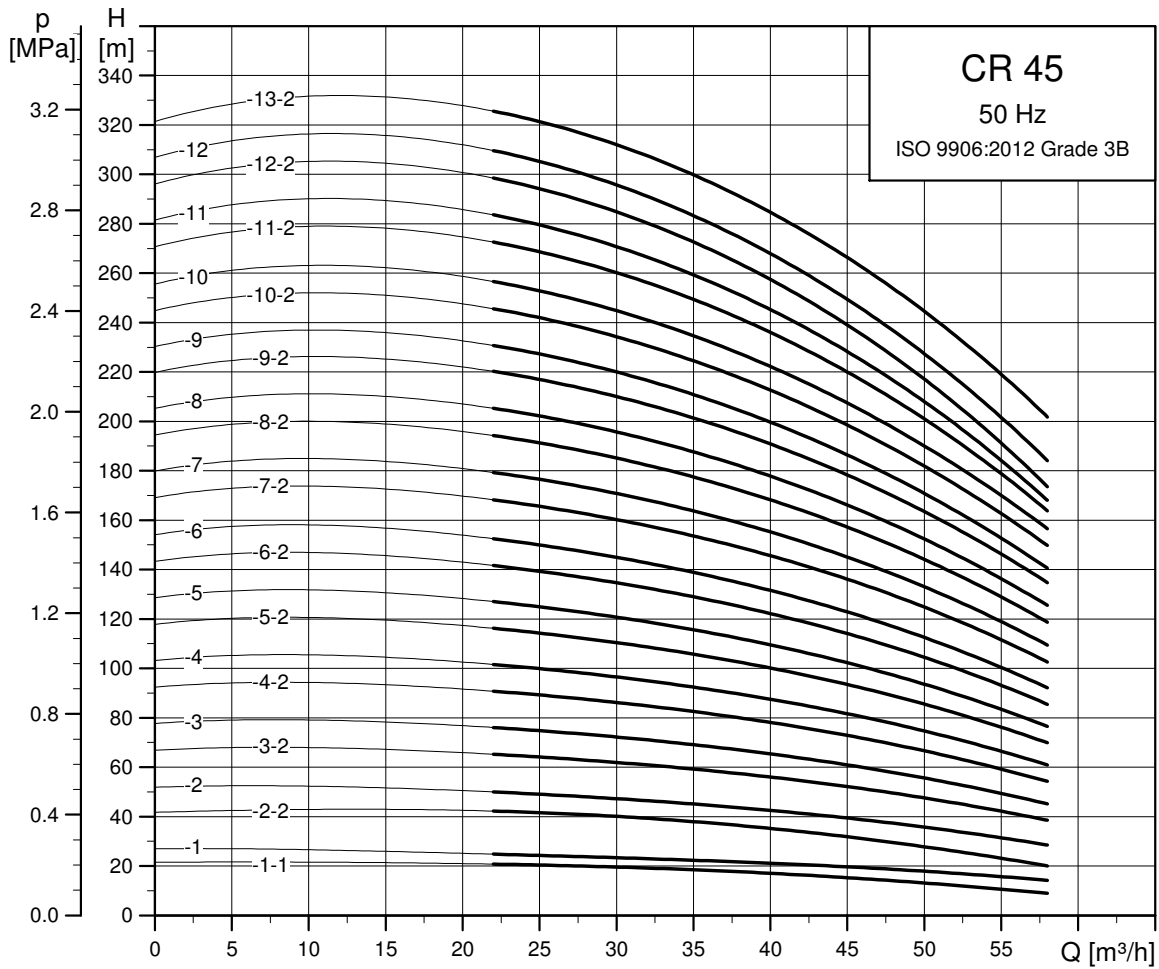

TM02 7304 0918

## Dimensional sketch

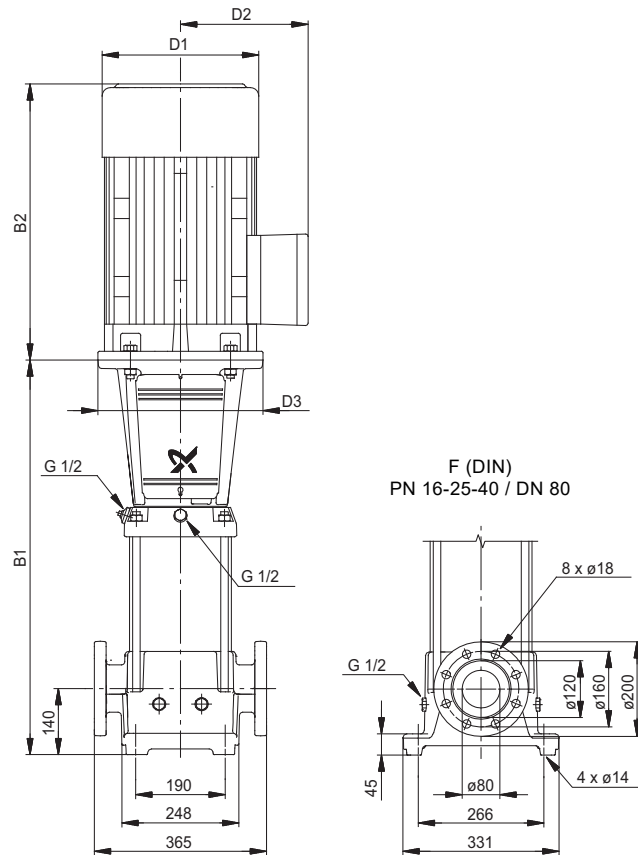

TM06 9600 2517

## Dimensions and weights

Pump type	Motor P <sub>2</sub> [kW]	CR					Net weight [kg]
		Dimension [mm]					
		B1	B1+B2	D1	D2	D3	
CR 45-1-1	3	559	894	198	120	-	82
CR 45-1	4	559	931	220	134	-	93
CR 45-2-2	5.5	639	1030	220	134	300	104
CR 45-2	7.5	639	1018	260	159	300	114
CR 45-3-2	11	829	1311	318	204	350	163
CR 45-3	11	829	1311	318	204	350	163
CR 45-4-2	15	909	1391	318	204	350	179
CR 45-4	15	909	1391	318	204	350	179
CR 45-5-2	18.5	989	1515	318	204	350	195
CR 45-5	18.5	989	1515	318	204	350	195
CR 45-6-2	22	1069	1621	318	204	350	217
CR 45-6	22	1069	1621	318	204	350	217
CR 45-7-2	30	1149	1760	396	315	400	324
CR 45-7	30	1149	1760	396	315	400	324
CR 45-8-2	30	1229	1840	396	315	400	328
CR 45-8	30	1229	1840	396	315	400	328
CR 45-9-2	30	1309	1920	396	315	400	332
CR 45-9	37	1309	1945	396	315	400	357
CR 45-10-2	37	1389	2025	396	315	400	362
CR 45-10	37	1389	2025	396	315	400	362
CR 45-11-2	45	1469	2177	449	338	450	455
CR 45-11	45	1469	2177	449	338	450	455
CR 45-12-2	45	1549	2257	449	338	450	460
CR 45-12	45	1549	2257	449	338	450	460
CR 45-13-2	45	1629	2337	449	338	450	464

**CRN 45**

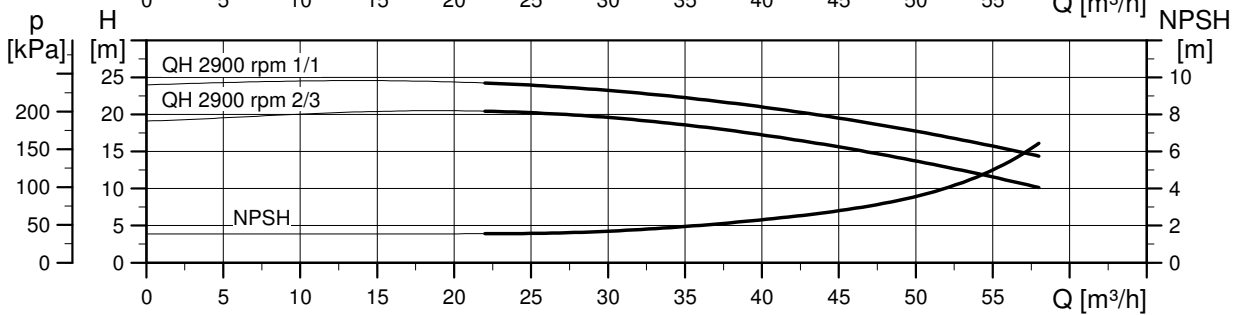
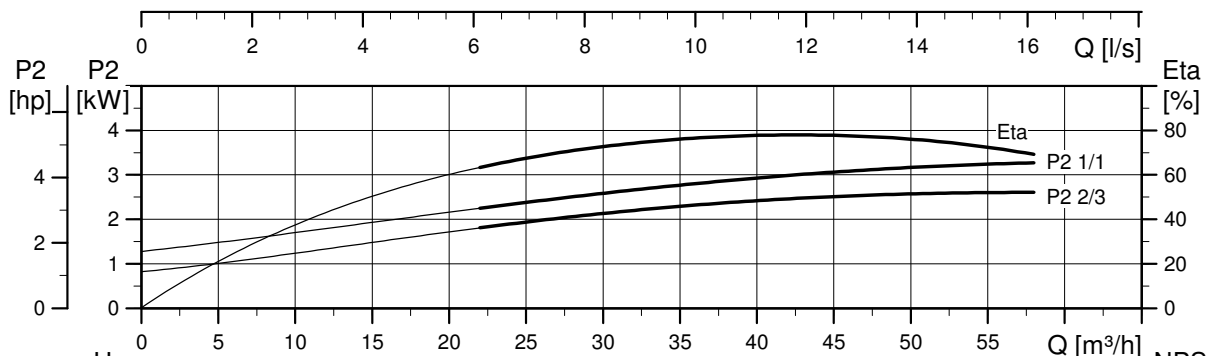
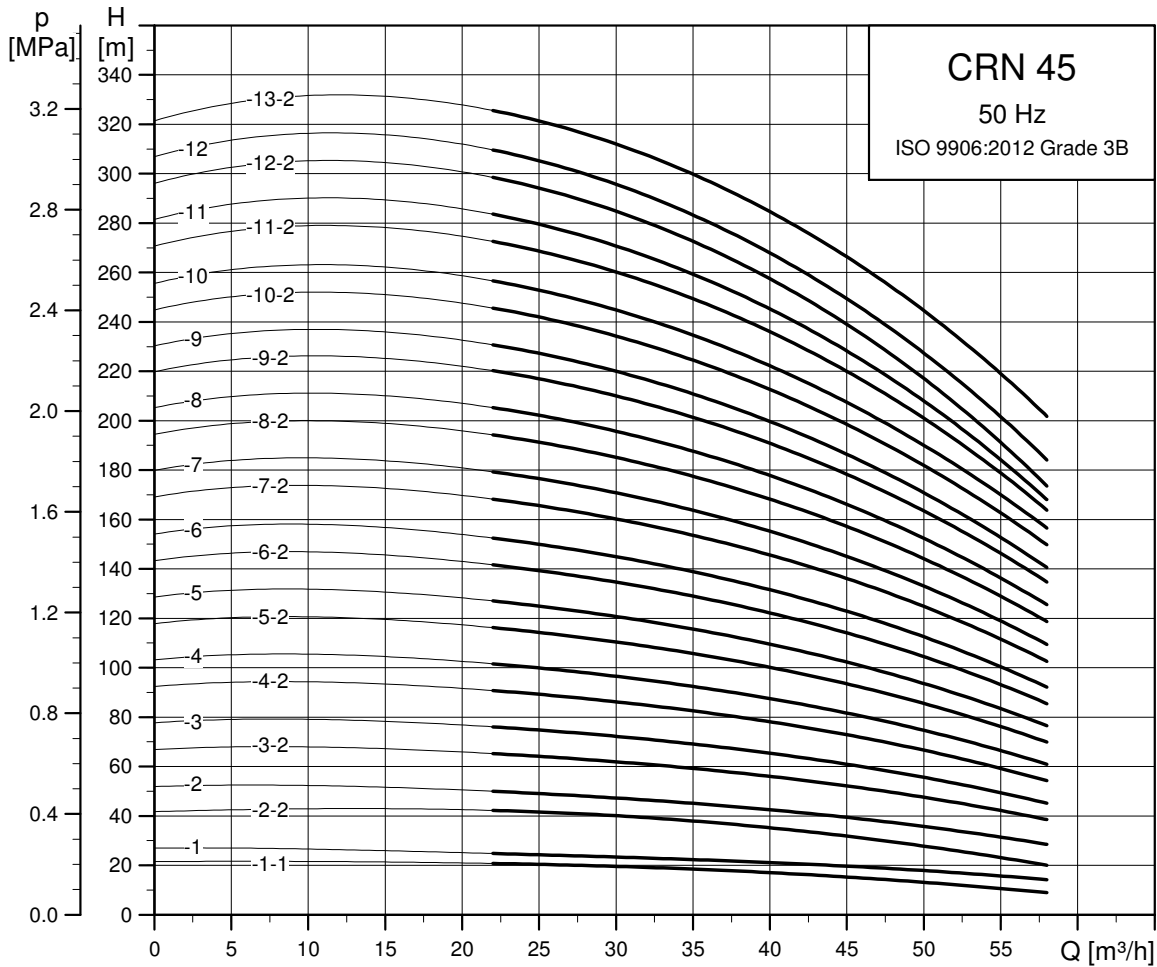

TM02 7305 0918

Dimensional sketch

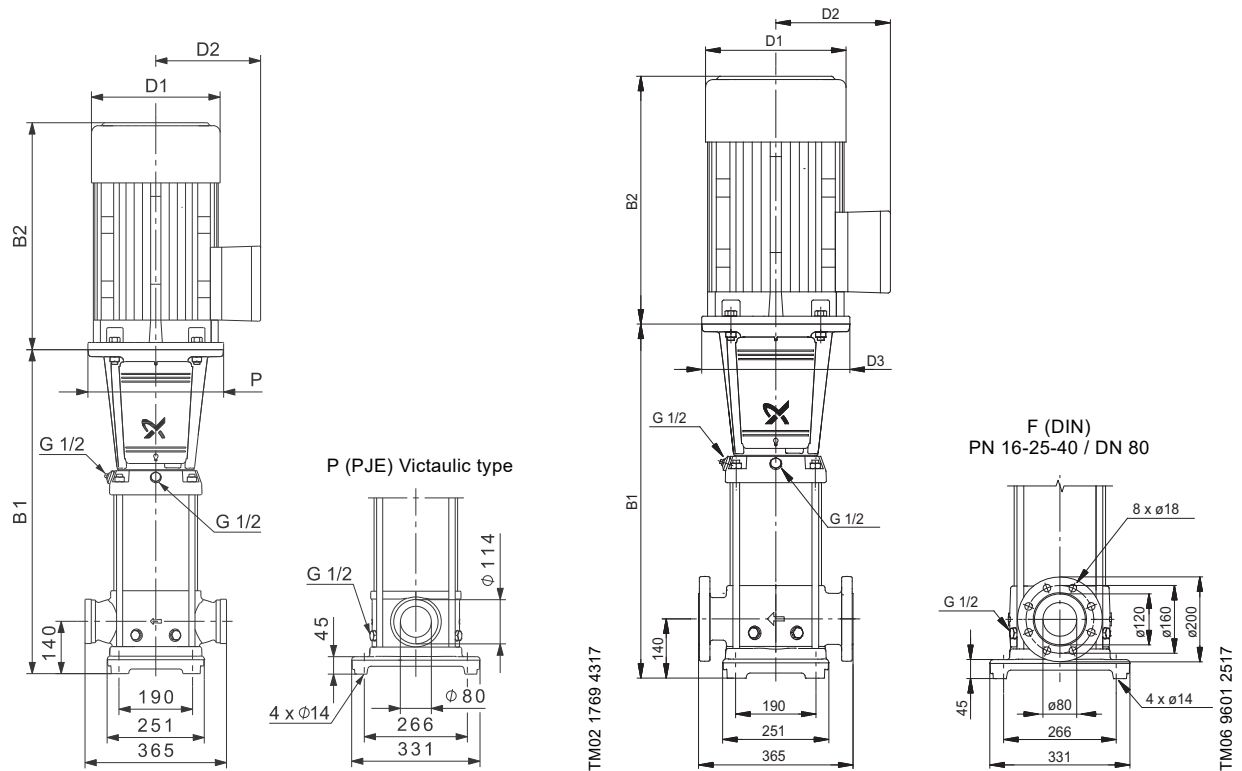

Dimensions and weights

Pump type	Motor P <sub>2</sub> [kW]	CRN					Net weight [kg]
		Dimension [mm]					
		B1	B1+B2	D1	D2	D3	
CRN 45-1-1	3	559	894	198	120	-	82
CRN 45-1	4	559	931	220	134	-	94
CRN 45-2-2	5.5	639	1030	220	134	300	105
CRN 45-2	7.5	639	1018	260	159	300	114
CRN 45-3-2	11	829	1311	318	204	350	164
CRN 45-3	11	829	1311	318	204	350	164
CRN 45-4-2	15	909	1391	318	204	350	179
CRN 45-4	15	909	1391	318	204	350	179
CRN 45-5-2	18.5	989	1515	318	204	350	195
CRN 45-5	18.5	989	1515	318	204	350	195
CRN 45-6-2	22	1069	1621	318	204	350	217
CRN 45-6	22	1069	1621	318	204	350	217
CRN 45-7-2	30	1149	1760	396	315	400	324
CRN 45-7	30	1149	1760	396	315	400	324
CRN 45-8-2	30	1229	1840	396	315	400	328
CRN 45-8	30	1229	1840	396	315	400	328
CRN 45-9-2	30	1309	1920	396	315	400	333
CRN 45-9	37	1309	1945	396	315	400	358
CRN 45-10-2	37	1389	2025	396	315	400	362
CRN 45-10	37	1389	2025	396	315	400	362
CRN 45-11-2	45	1469	2177	449	338	450	455
CRN 45-11	45	1469	2177	449	338	450	455
CRN 45-12-2	45	1549	2257	449	338	450	460
CRN 45-12	45	1549	2257	449	338	450	460
CRN 45-13-2	45	1629	2337	449	338	450	464

**CR 64**

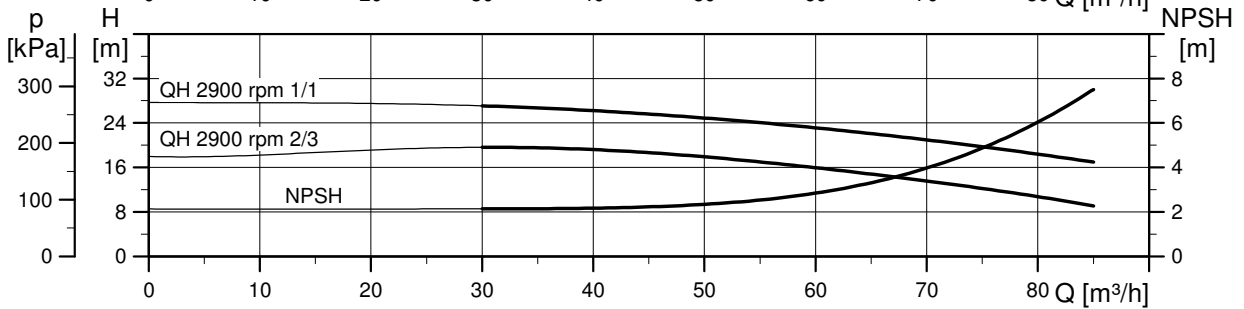
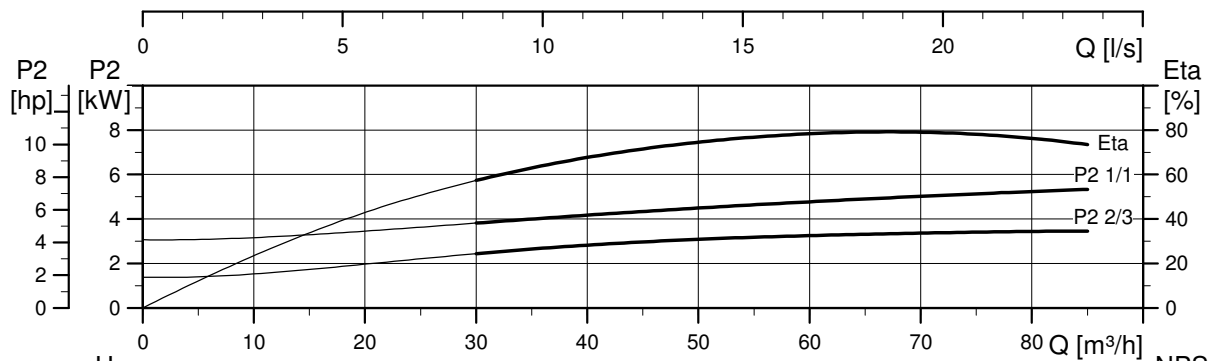
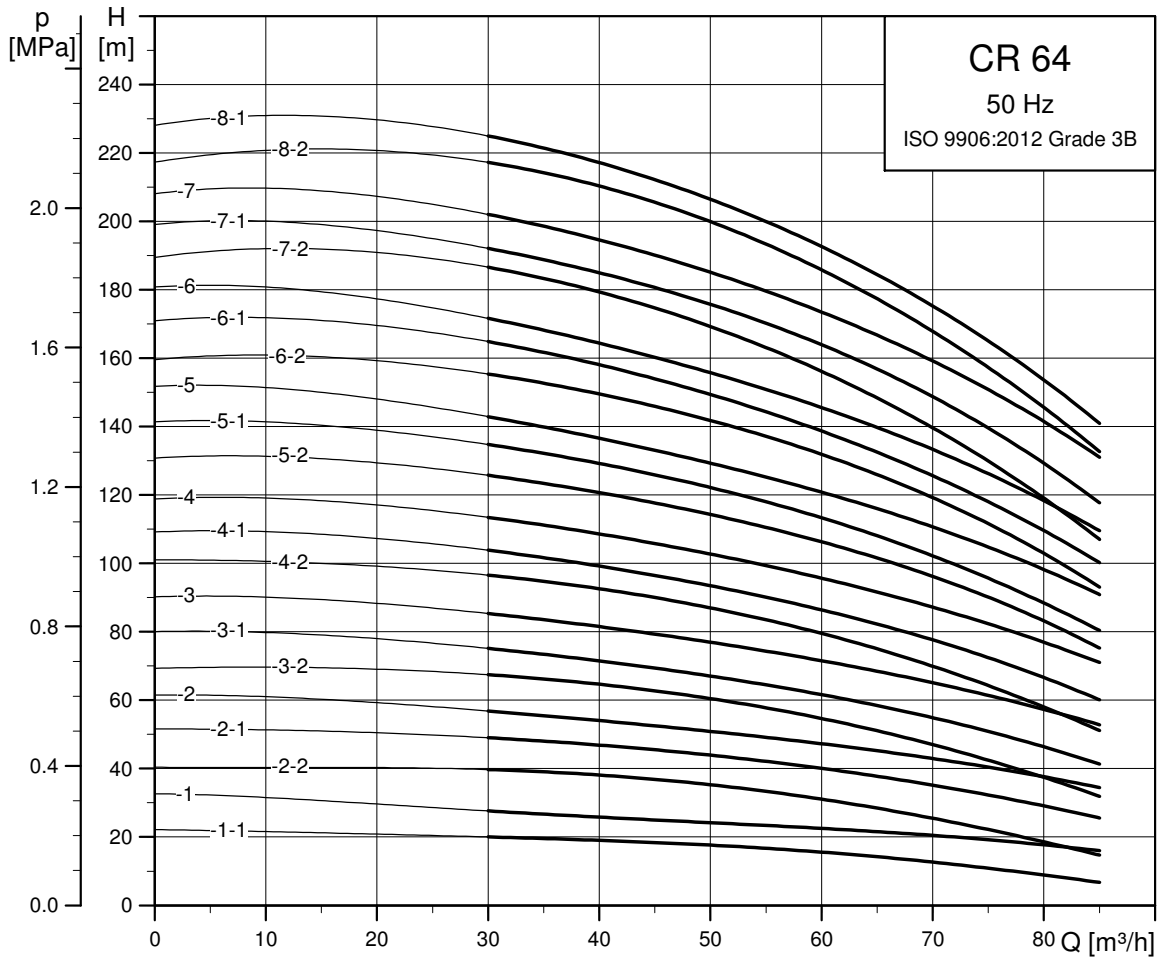

TM02 7306 0918

Dimensional sketch

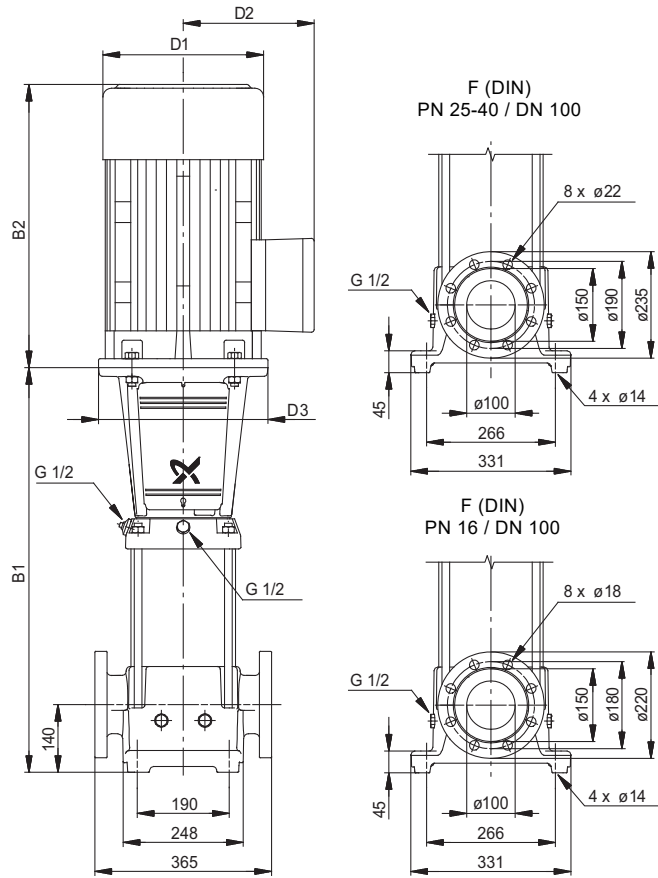

TM06 9606 2517

Dimensions and weights

Pump type	Motor P <sub>2</sub> [kW]	CR					Net weight [kg]
		Dimension [mm]					
		B1	B1+B2	D1	D2	D3	
CR 64-1-1	4	561	933	220	134	-	96
CR 64-1	5.5	561	952	220	134	300	103
CR 64-2-2	7.5	644	1023	260	159	300	117
CR 64-2-1	11	754	1236	318	204	350	162
CR 64-2	11	754	1236	318	204	350	162
CR 64-3-2	15	836	1318	318	204	350	179
CR 64-3-1	15	836	1318	318	204	350	179
CR 64-3	18.5	836	1362	318	204	350	191
CR 64-4-2	18.5	919	1445	318	204	350	196
CR 64-4-1	22	919	1471	318	204	350	211
CR 64-4	22	919	1471	318	204	350	211
CR 64-5-2	30	1001	1612	396	315	400	318
CR 64-5-1	30	1001	1612	396	315	400	318
CR 64-5	30	1001	1612	396	315	400	318
CR 64-6-2	30	1084	1695	396	315	400	324
CR 64-6-1	37	1084	1720	396	315	400	349
CR 64-6	37	1084	1720	396	315	400	349
CR 64-7-2	37	1166	1802	396	315	400	354
CR 64-7-1	37	1166	1802	396	315	400	354
CR 64-7	45	1166	1874	449	338	450	443
CR 64-8-2	45	1249	1957	449	338	450	448
CR 64-8-1	45	1249	1957	449	338	450	448

**CRN 64**

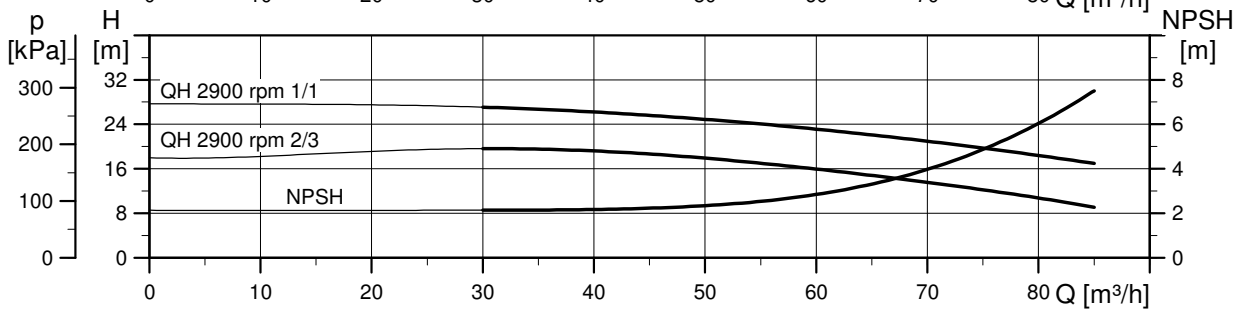
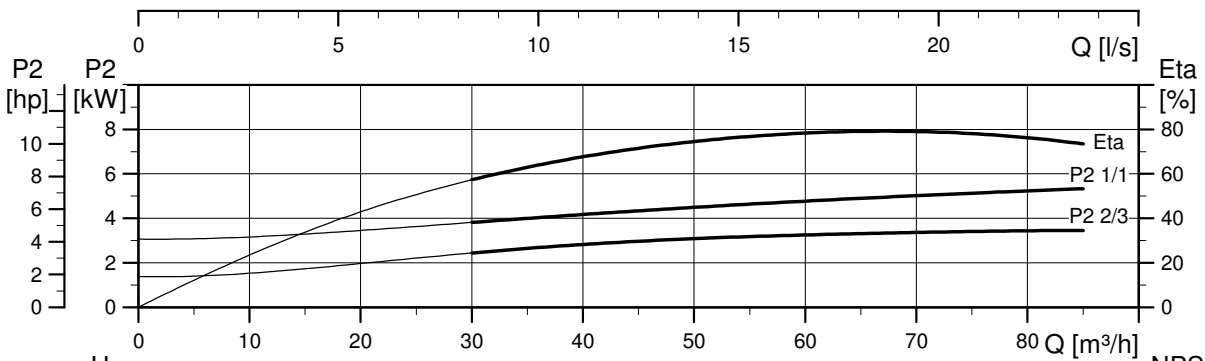
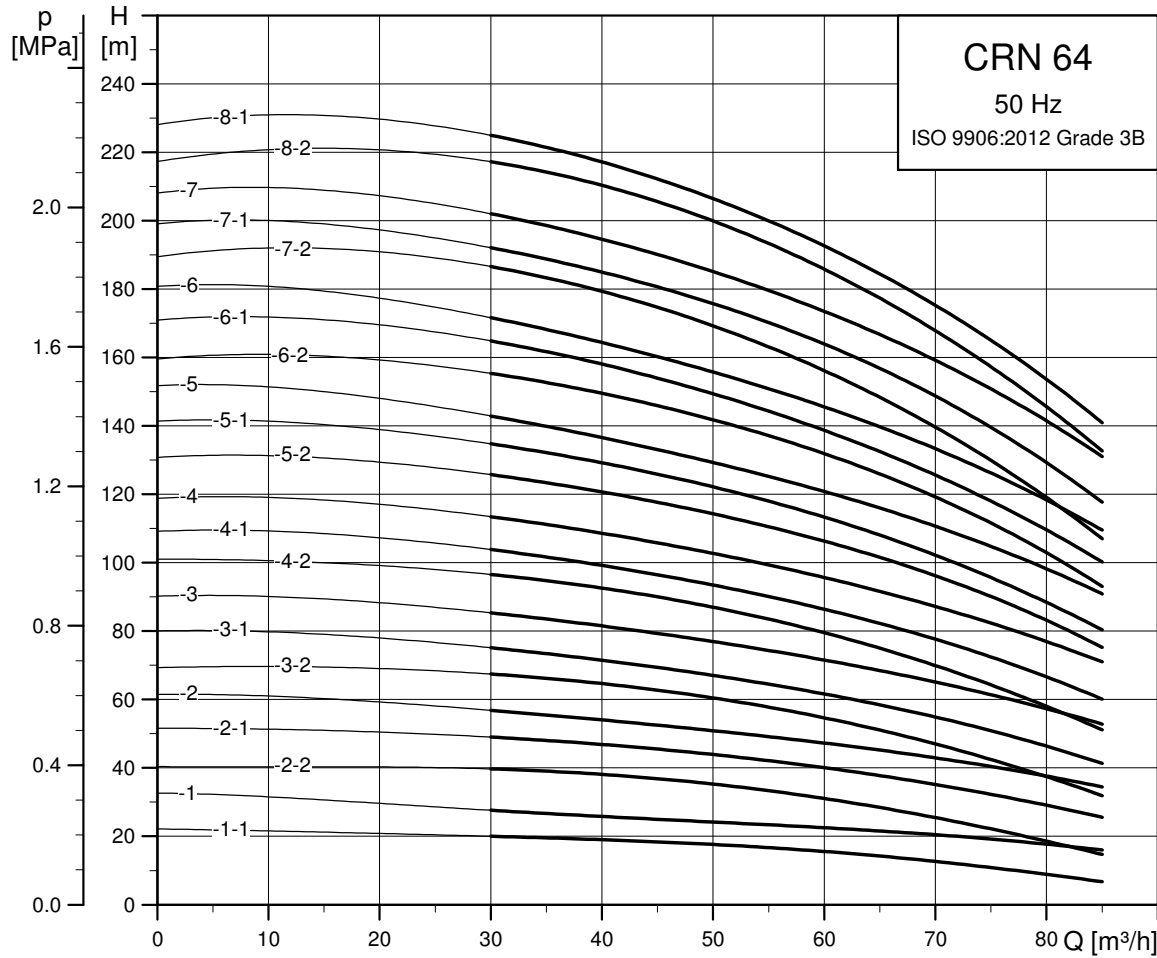

TM02 7307 09 18

Dimensional sketch

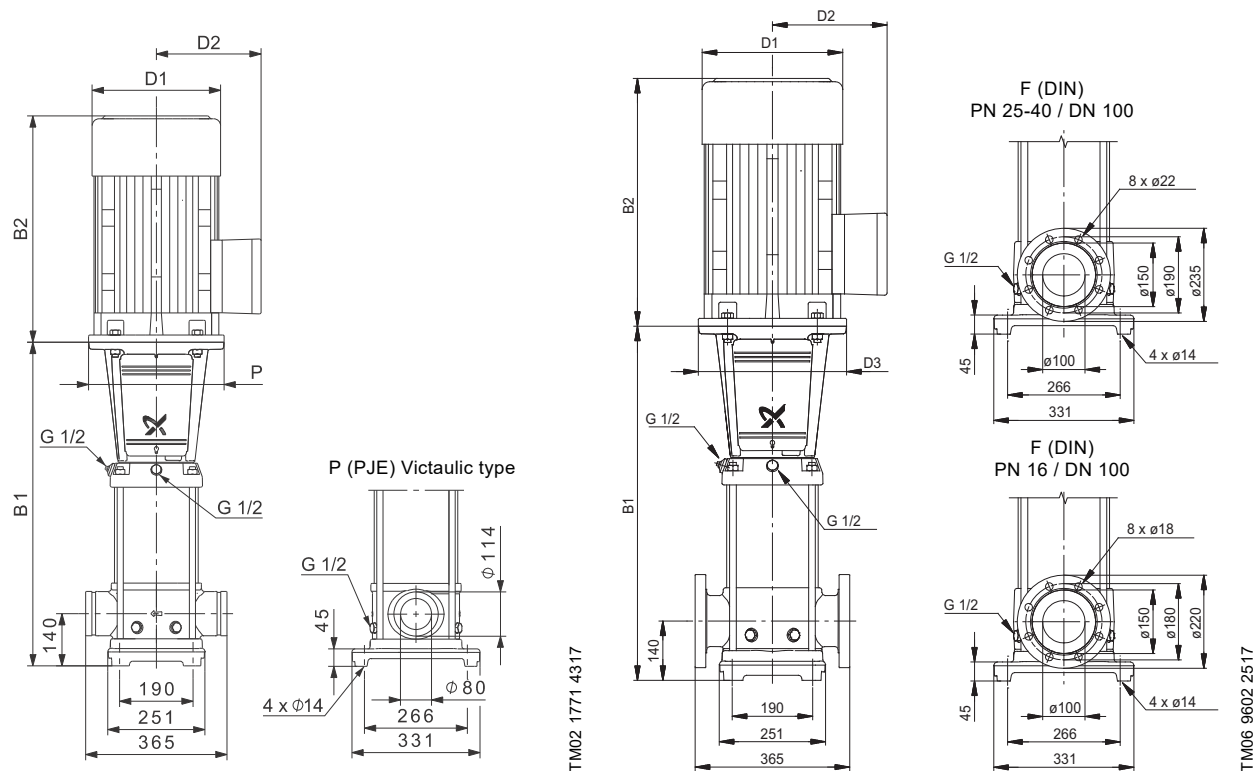

Dimensions and weights

Pump type	Motor P <sub>2</sub> [kW]	CRN					Net weight [kg]
		Dimension [mm]					
		B1	B1+B2	D1	D2	D3	
CRN 64-1-1	4	561	933	220	134	-	95
CRN 64-1	5.5	561	952	220	134	300	103
CRN 64-2-2	7.5	644	1023	260	159	300	117
CRN 64-2-1	11	754	1236	318	204	350	162
CRN 64-2	11	754	1236	318	204	350	162
CRN 64-3-2	15	836	1318	318	204	350	178
CRN 64-3-1	15	836	1318	318	204	350	178
CRN 64-3	18.5	836	1362	318	204	350	191
CRN 64-4-2	18.5	919	1445	318	204	350	196
CRN 64-4-1	22	919	1471	318	204	350	211
CRN 64-4	22	919	1471	318	204	350	211
CRN 64-5-2	30	1001	1612	396	315	400	318
CRN 64-5-1	30	1001	1612	396	315	400	318
CRN 64-5	30	1001	1612	396	315	400	318
CRN 64-6-2	30	1084	1695	396	315	400	325
CRN 64-6-1	37	1084	1720	396	315	400	350
CRN 64-6	37	1084	1720	396	315	400	350
CRN 64-7-2	37	1166	1802	396	315	400	354
CRN 64-7-1	37	1166	1802	396	315	400	354
CRN 64-7	45	1166	1874	449	338	450	444
CRN 64-8-2	45	1249	1957	449	338	450	448
CRN 64-8-1	45	1249	1957	449	338	450	448

CR 95

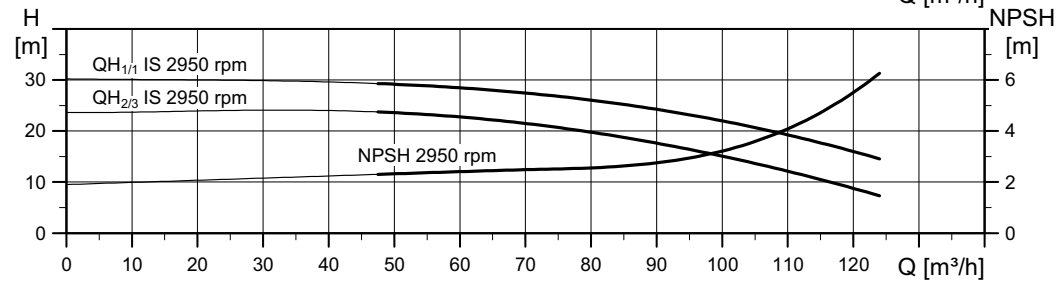
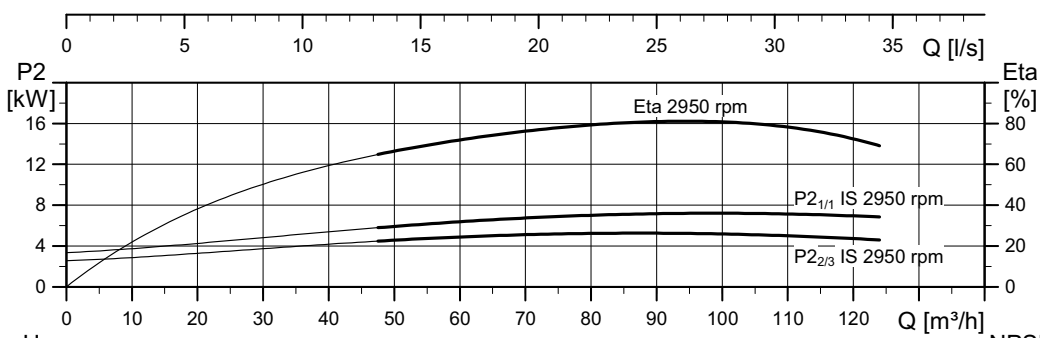
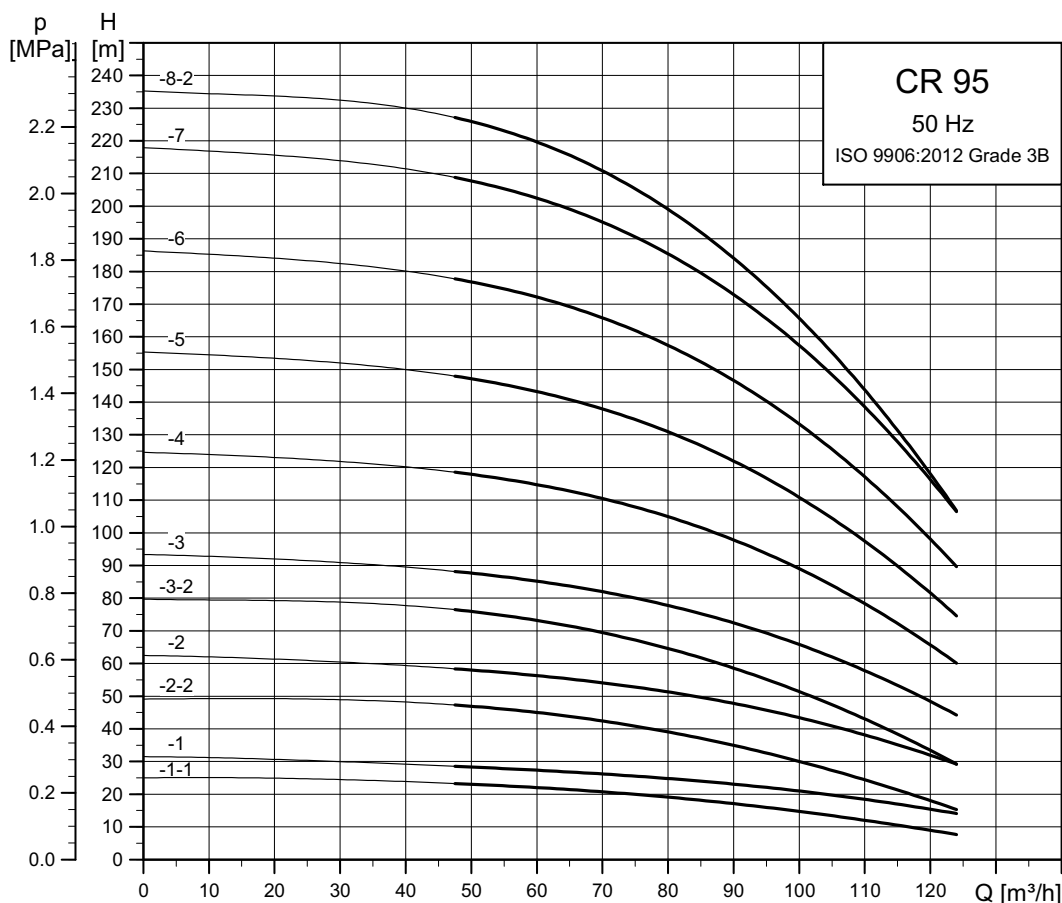

The pump efficiency (ETA) is based on a three-stage pump.

TM06 5 113 0721

Dimensional sketch

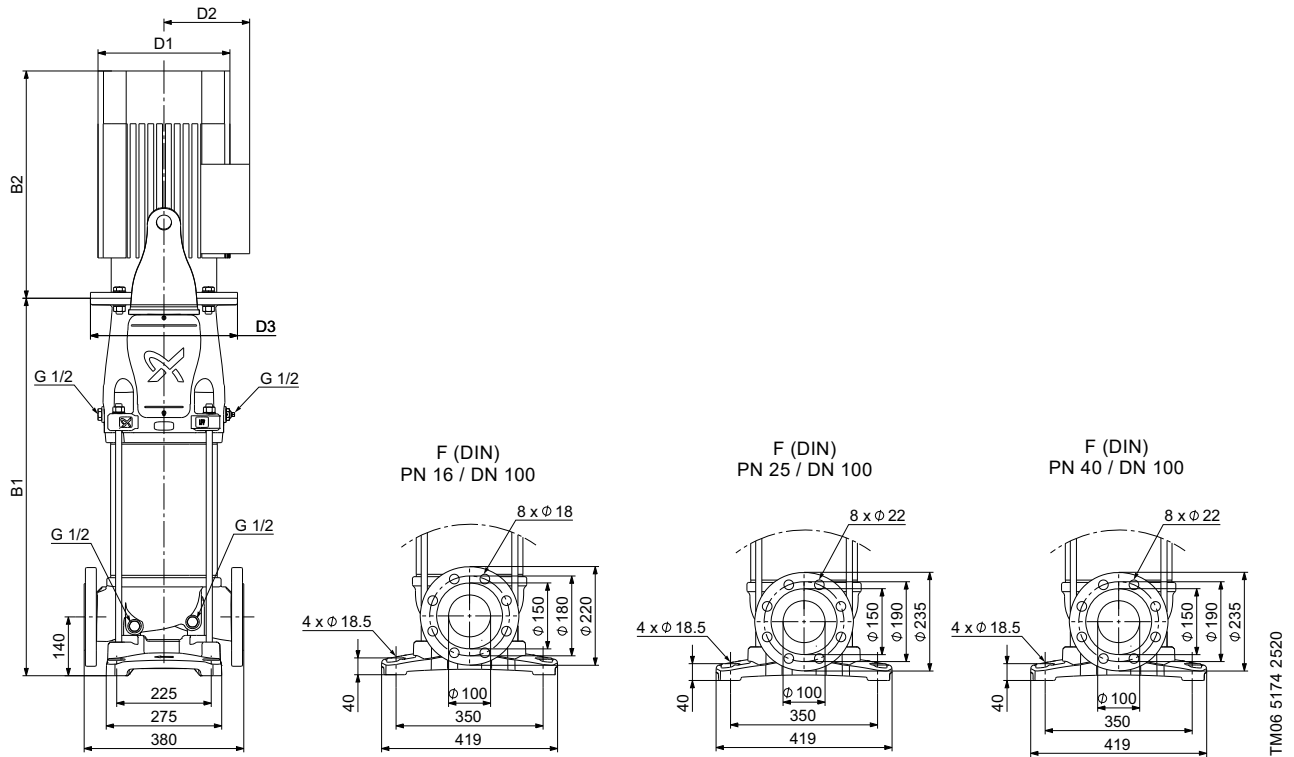

Dimensions and weights

Pump type	Motor P <sub>2</sub> [kW]	CR					Net weight [kg]
		Dimension [mm]					
		B1	B1+B2	D1	D2	D3	
CR 95-1-1	5.5	689	1080	220	134	300	137
CR 95-1	7.5	689	1068	260	159	300	147
CR 95-2-2	11	795	1277	318	204	350	194
CR 95-2	15	795	1277	318	204	350	206
CR 95-3-2	18.5	900	1426	318	204	350	224
CR 95-3	22	900	1452	318	204	350	239
CR 95-4	30	1009	1620	396	315	400	348
CR 95-5	37	1114	1750	396	315	400	379
CR 95-6	45	1238	1946	449	338	450	480
CR 95-7	55	1342	2089	497	410	550	598
CR 95-8-2	55	1446	2193	497	410	550	604

**CRN 95**

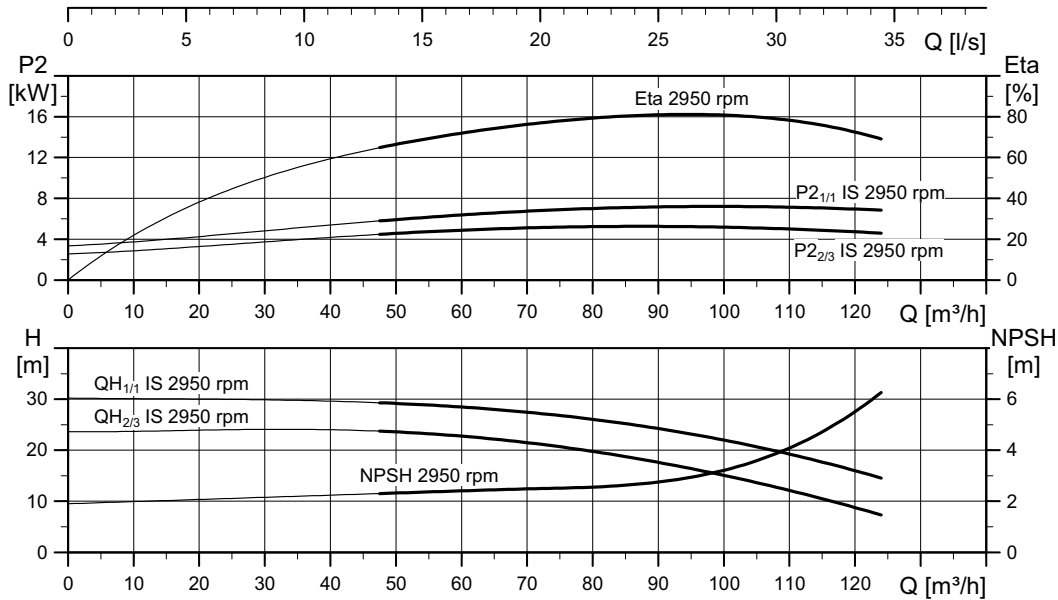
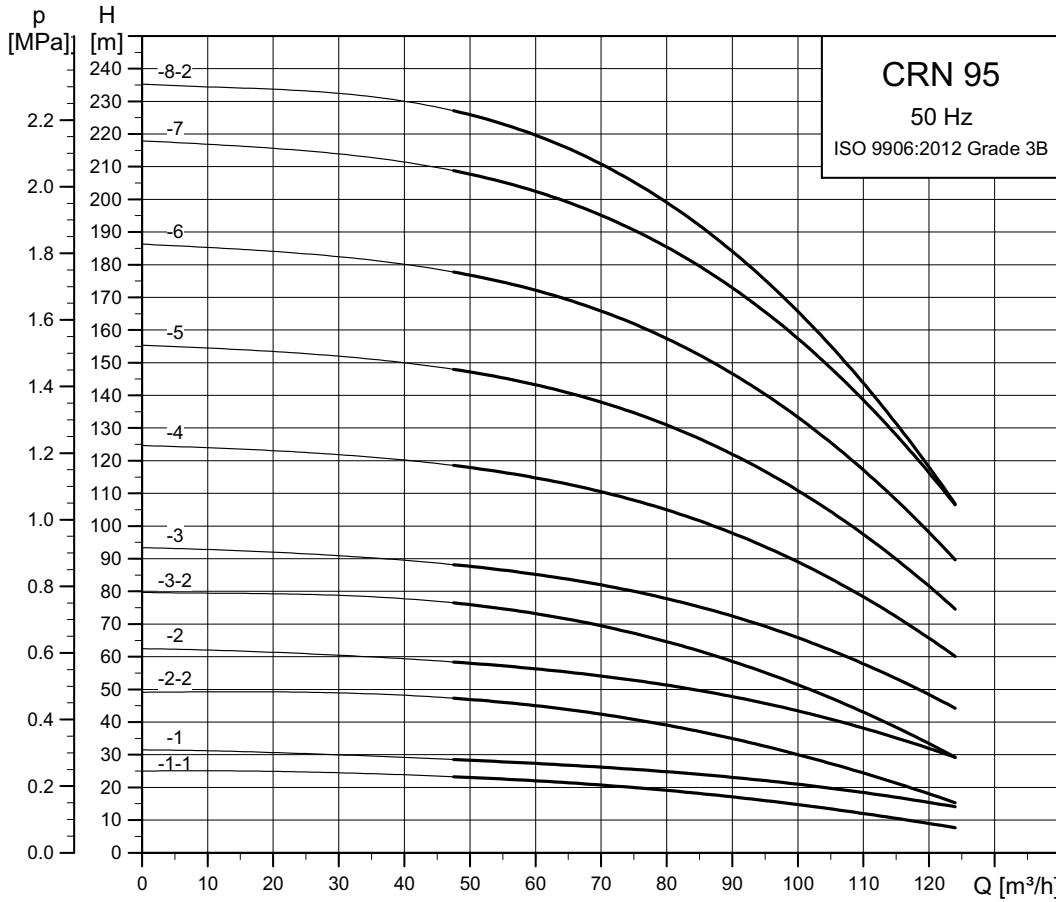

The pump efficiency (ETA) is based on a three-stage pump.

TM06 5125 0721

Dimensional sketch

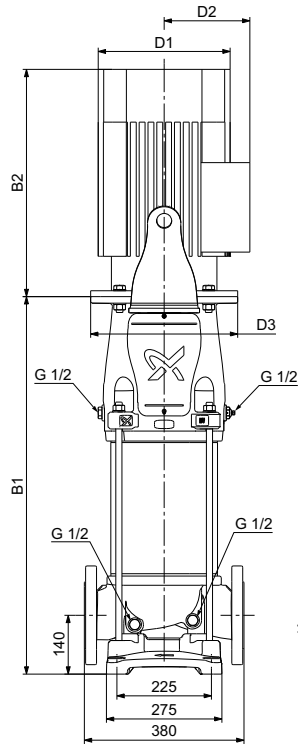

P (PJE) Victaulic type

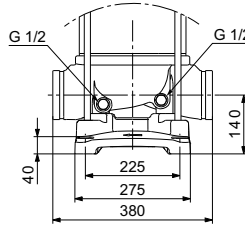

P (PJE) Victaulic type

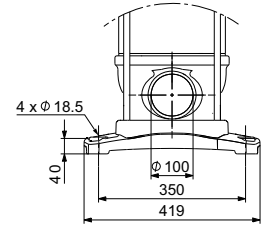

F (DIN)  
PN 16 / DN 100

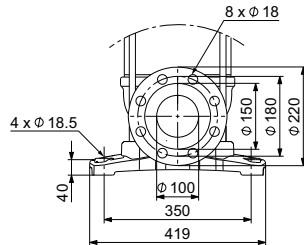

F (DIN)  
PN 25 / DN 100

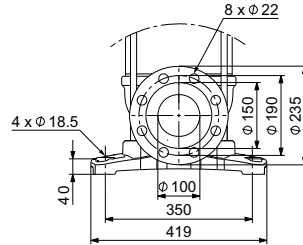

F (DIN)  
PN 40 / DN 100

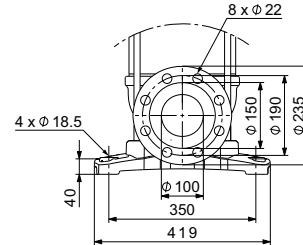

TM06 5094 2520

Dimensions and weights

Pump type	Motor P <sub>2</sub> [kW]	CRN					Net weight [kg]
		Dimension [mm]					
		B1	B1+B2	D1	D2	D3	
CRN 95-1-1	5.5	689	1080	220	134	300	137
CRN 95-1	7.5	689	1068	260	159	300	147
CRN 95-2-2	11	795	1277	318	204	350	194
CRN 95-2	15	795	1277	318	204	350	206
CRN 95-3-2	18.5	900	1426	318	204	350	224
CRN 95-3	22	900	1452	318	204	350	239
CRN 95-4	30	1009	1620	396	315	400	348
CRN 95-5	37	1114	1750	396	315	400	379
CRN 95-6	45	1238	1946	449	338	450	480
CRN 95-7	55	1342	2089	497	410	550	598
CRN 95-8-2	55	1446	2193	497	410	550	604

CR 125

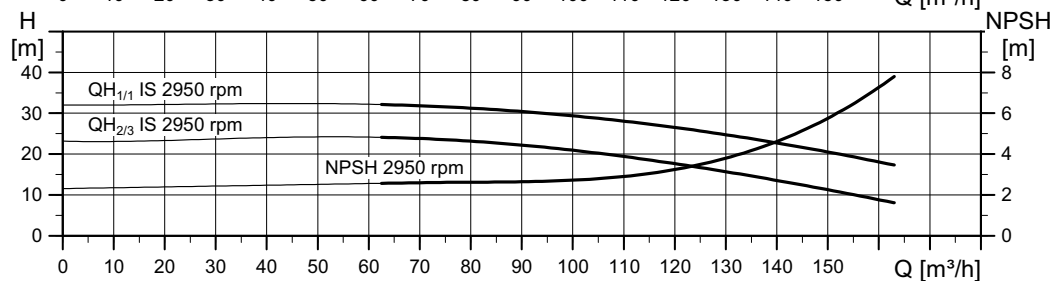
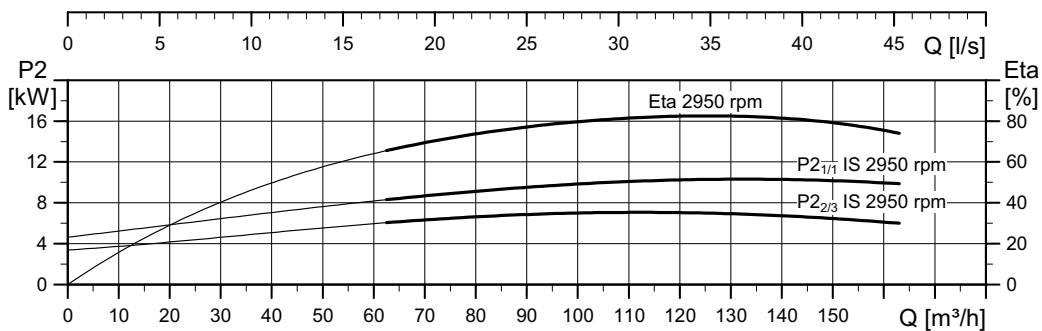
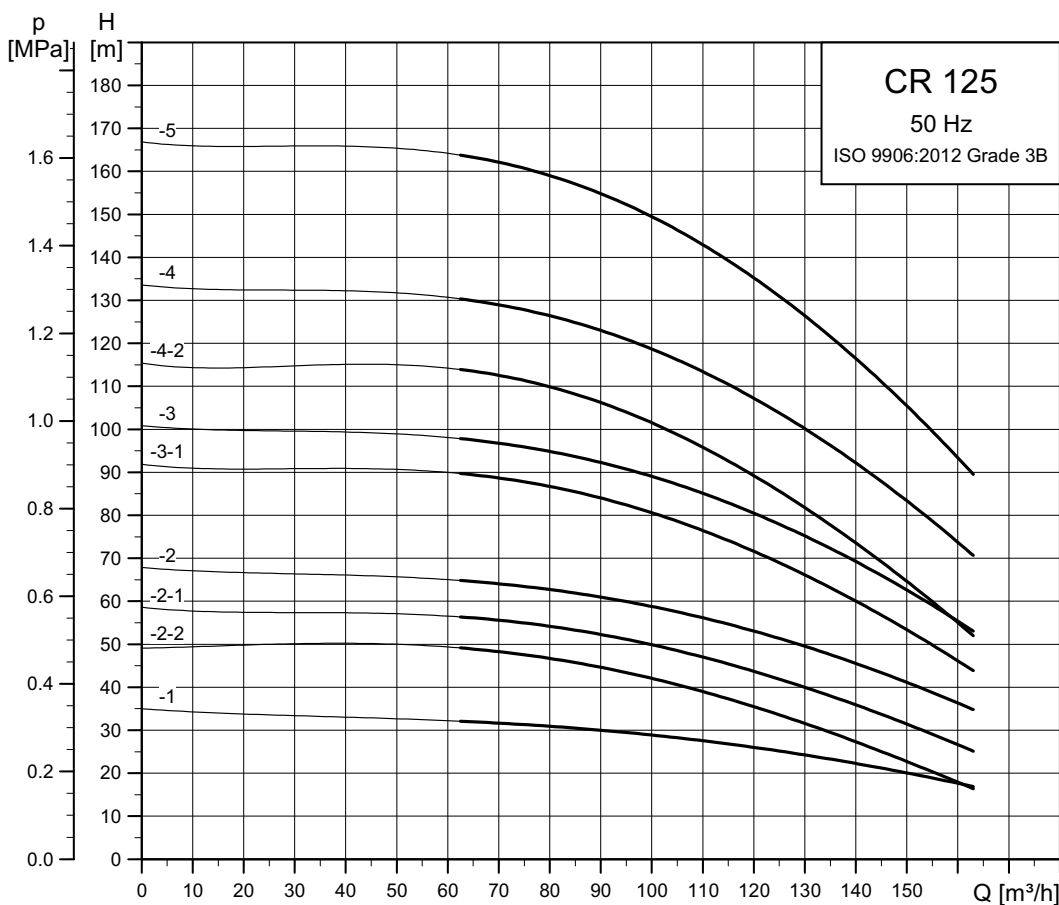

The pump efficiency (ETA) is based on a three-stage pump.

TM06 5114 0721

Dimensional sketch

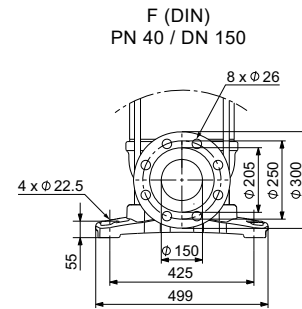
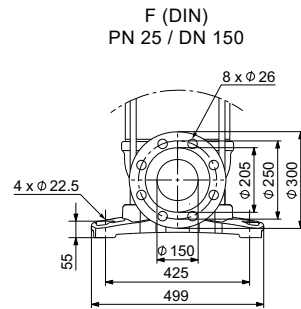
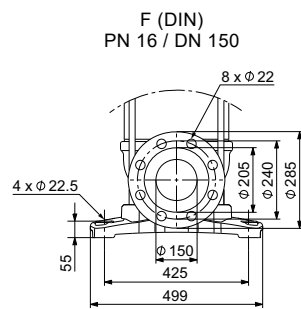
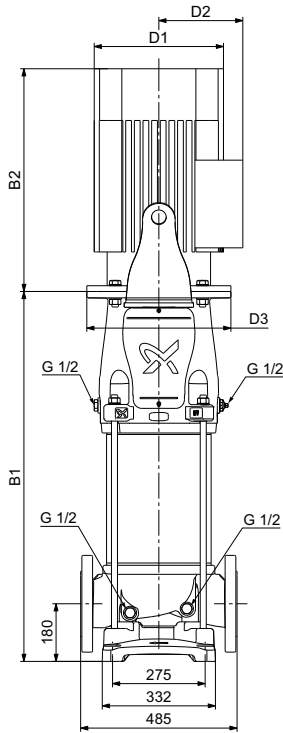

TM06 5175 0621

Dimensions and weights

Pump type	Motor P <sub>2</sub> [kW]	CR					Net weight [kg]
		Dimension [mm]					
		B1	B1+B2	D1	D2	D3	
CR 125-1	11	783	1265	318	204	350	233
CR 125-2-2	15	905	1387	318	204	350	255
CR 125-2-1	18.5	905	1431	318	204	350	268
CR 125-2	22	905	1457	318	204	350	283
CR 125-3-1	30	1029	1640	396	315	400	396
CR 125-3	37	1029	1665	396	315	400	421
CR 125-4-2	37	1151	1787	396	315	400	432
CR 125-4	45	1174	1882	449	338	450	526
CR 125-5	55	1295	2042	497	410	550	647

**CRN 125**

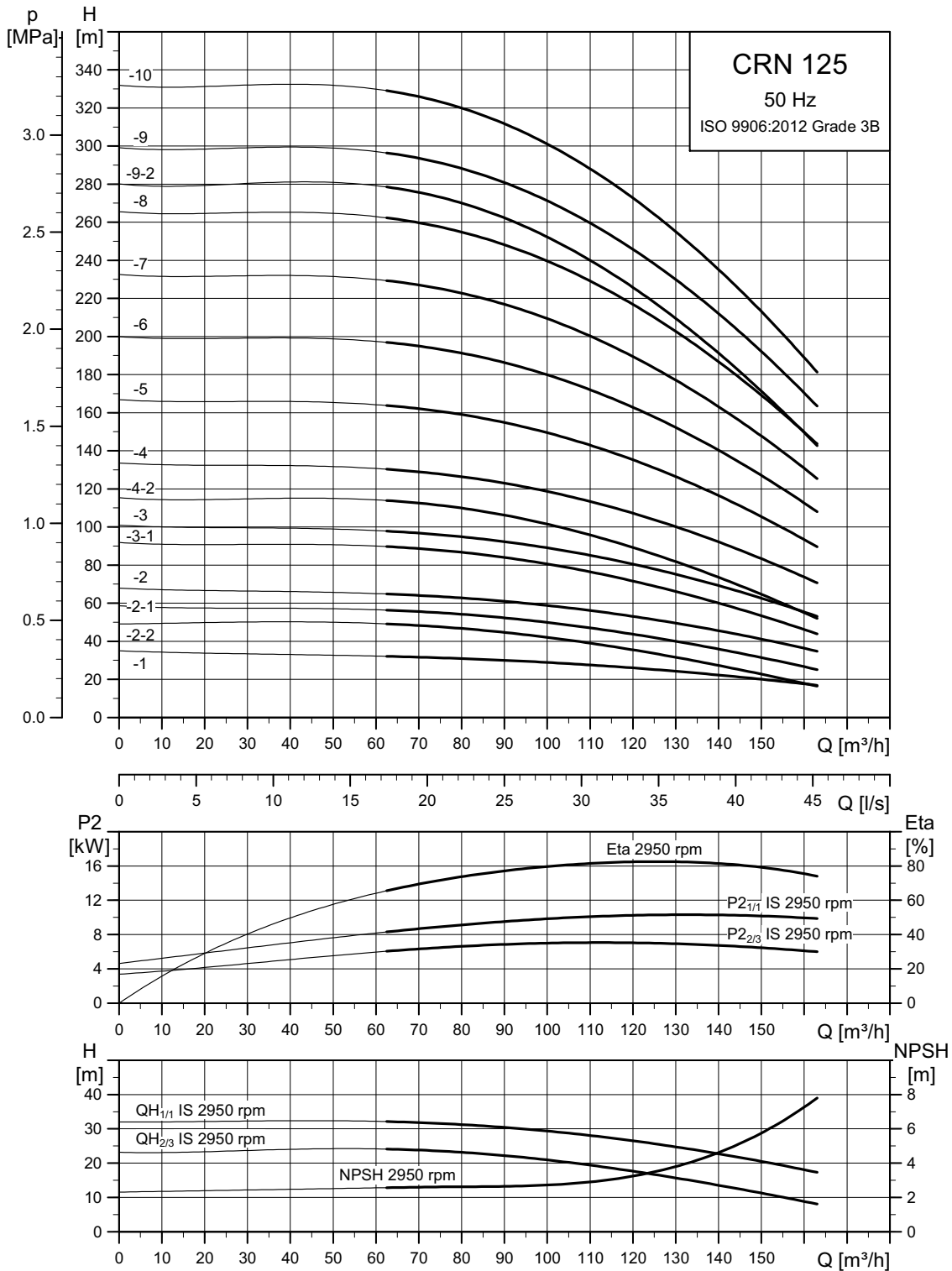

The pump efficiency (ETA) is based on a three-stage pump.

TM06 5126 0721

Dimensional sketch

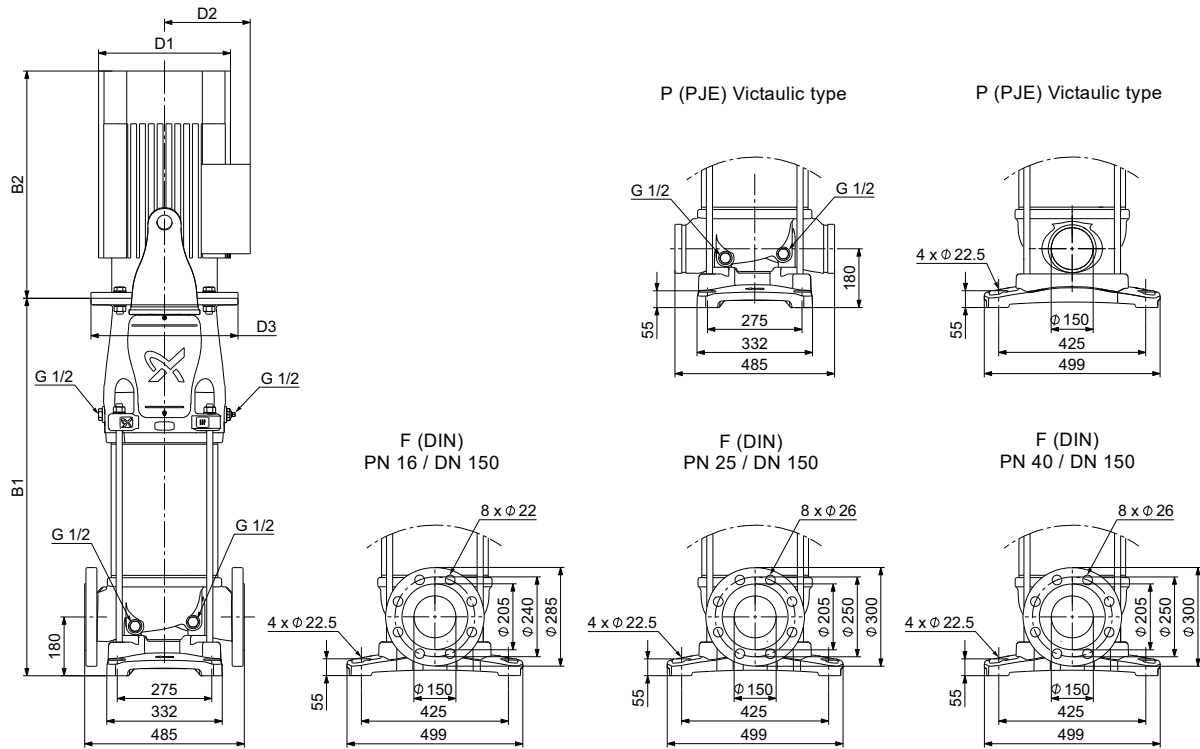

TM06 5095 0621

Dimensions and weights

Pump type	Motor P <sub>2</sub> [kW]	CRN					Net weight [kg]
		Dimension [mm]					
		B1	B1+B2	D1	D2	D3	
CRN 125-1	11	783	1265	318	204	350	233
CRN 125-2-2	15	905	1387	318	204	350	255
CRN 125-2-1	18.5	905	1431	318	204	350	268
CRN 125-2	22	905	1457	318	204	350	283
CRN 125-3-1	30	1029	1640	396	315	400	396
CRN 125-3	37	1029	1665	396	315	400	421
CRN 125-4-2	37	1151	1787	396	315	400	432
CRN 125-4	45	1174	1882	449	338	450	526
CRN 125-5	55	1295	2042	497	410	550	647
CRN 125-6	75	1417	2237	551	433	550	771
CRN 125-7	75	1539	2359	551	433	550	782
CRN 125-8	90	1661	2591	551	433	550	872
CRN 125-9-2	90	1783	2713	551	433	550	882
CRN 125-9	110	1813	2725	616	515	660	1075
CRN 125-10	110	1935	2847	616	515	660	1085

**CR 155**

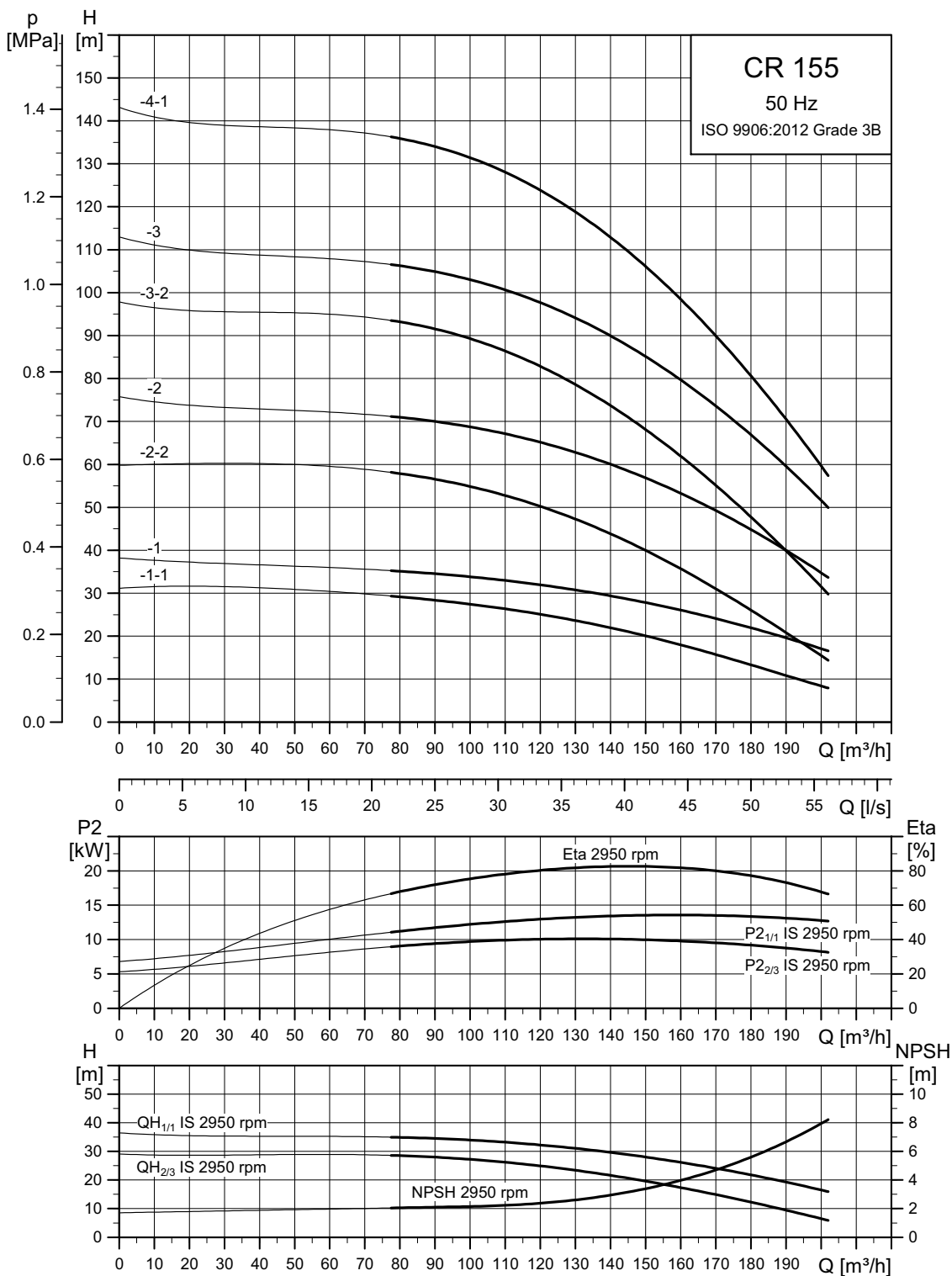

The pump efficiency (ETA) is based on a three-stage pump.

TM06 5115 0721

Dimensional sketch

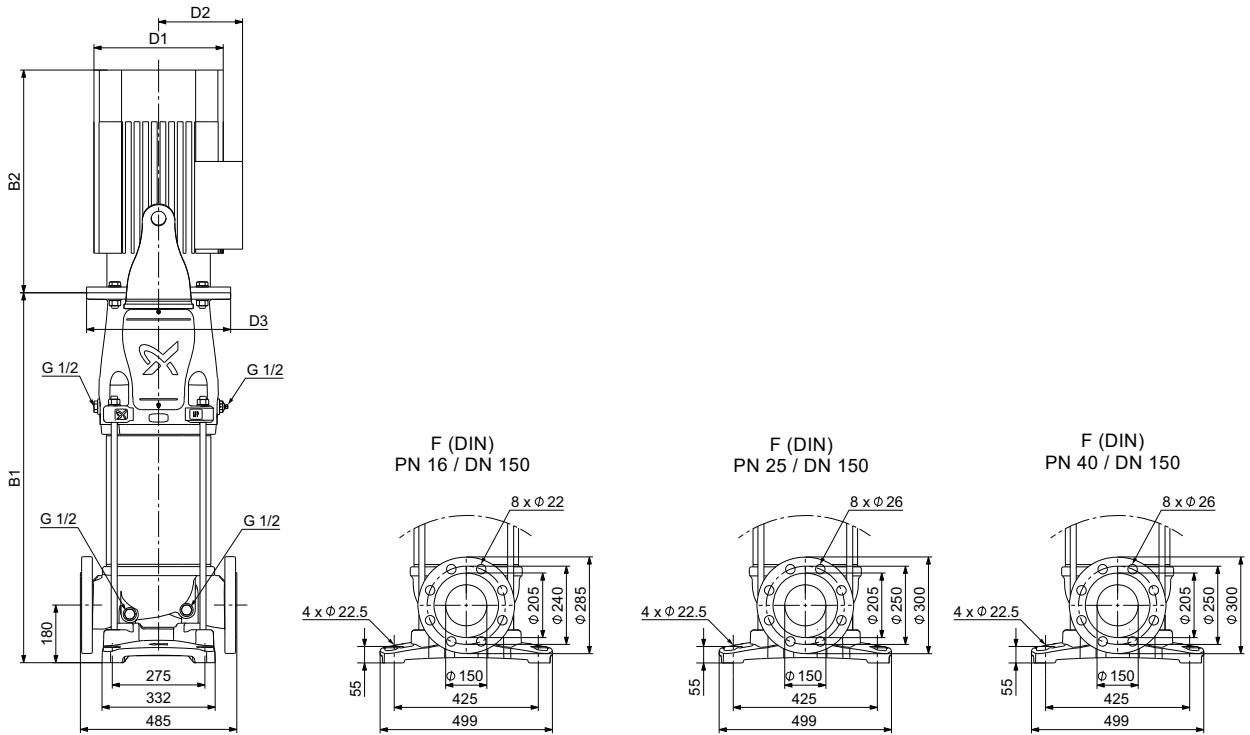

TM06 5175 0621

Dimensions and weights

Pump type	Motor P <sub>2</sub> [kW]	CR					Net weight [kg]
		Dimension [mm]					
		B1	B1+B2	D1	D2	D3	
CR 155-1-1	11	783	1265	318	204	350	234
CR 155-1	15	783	1265	318	204	350	245
CR 155-2-2	22	905	1457	318	204	350	284
CR 155-2	30	907	1518	396	315	400	387
CR 155-3-2	37	1029	1665	396	315	400	423
CR 155-3	45	1052	1760	449	338	450	517
CR 155-4-1	55	1173	1920	497	410	550	637

**CRN 155**

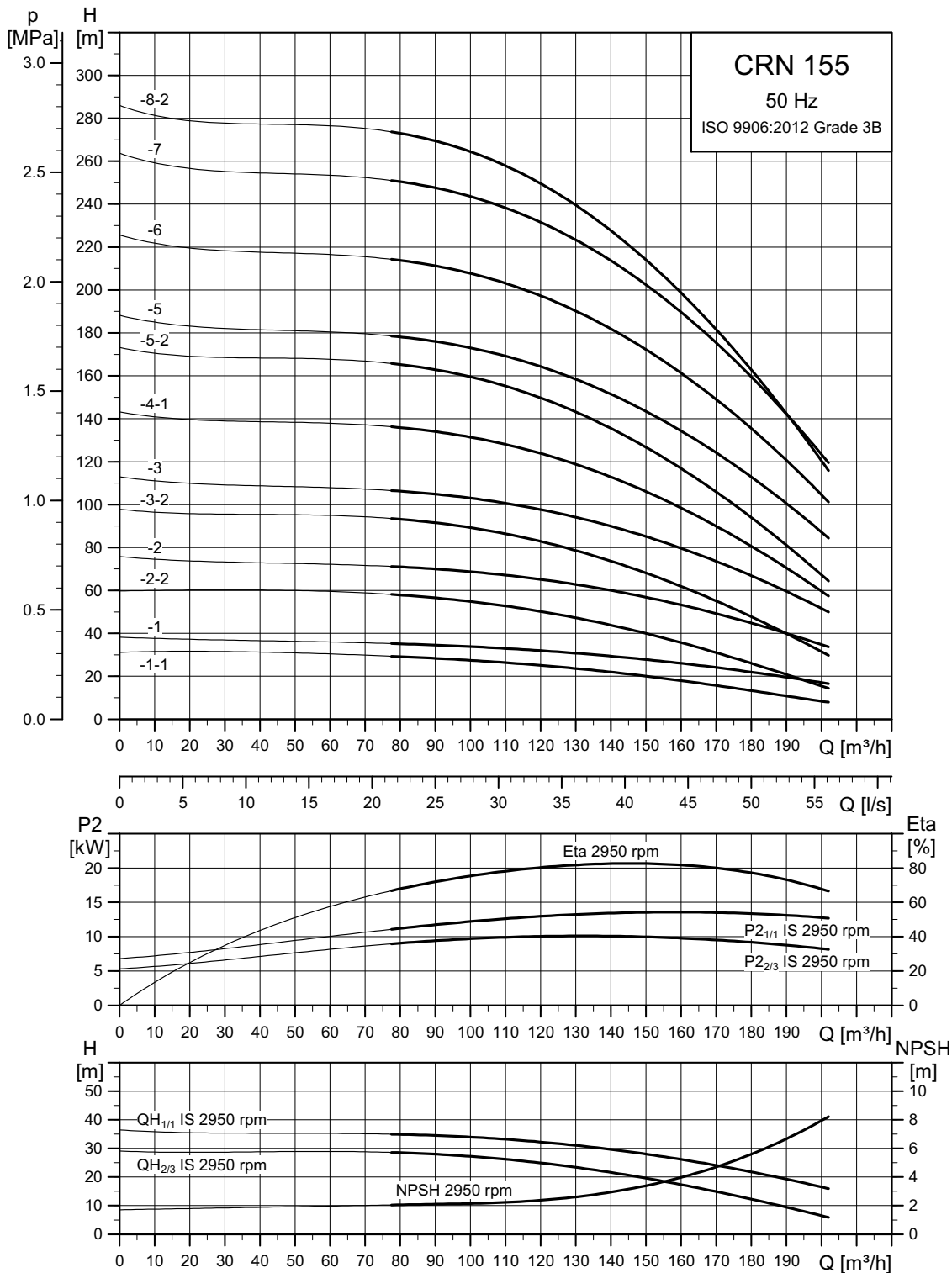

The pump efficiency (ETA) is based on a three-stage pump.

TM06 5127 0721

Dimensional sketch

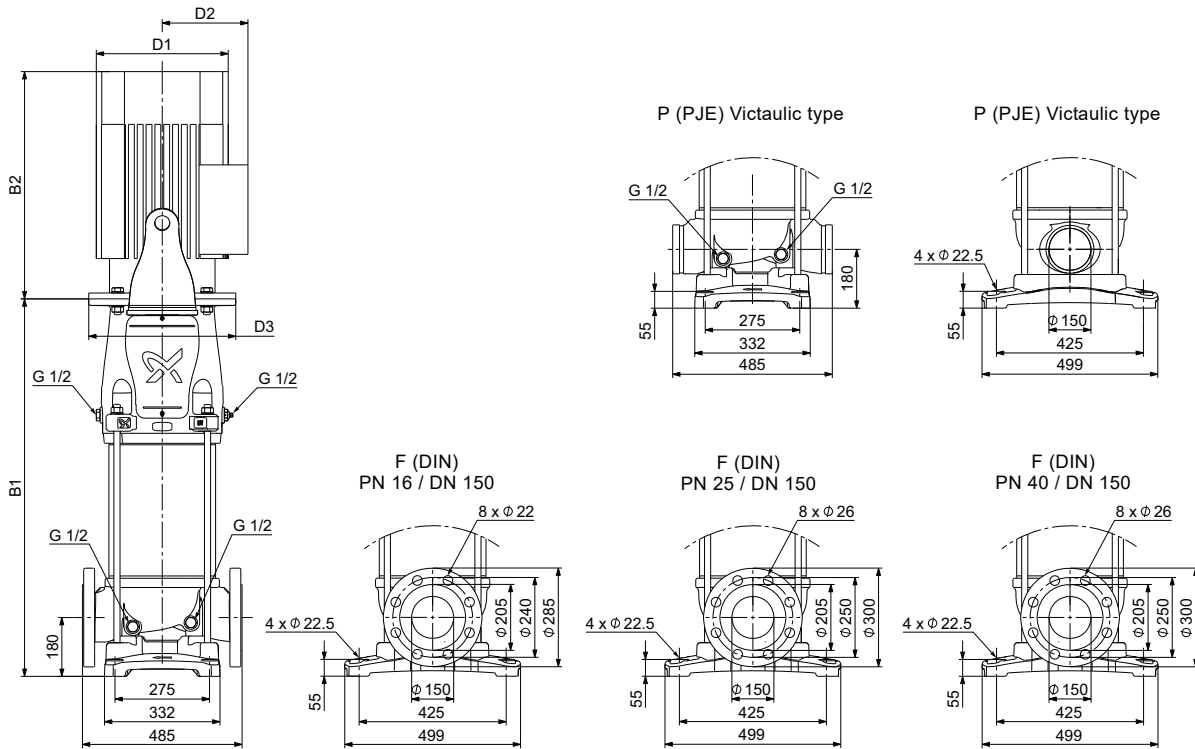

TM06 5095 0621

Dimensions and weights

Pump type	Motor P <sub>2</sub> [kW]	CRN					Net weight [kg]
		Dimension [mm]					
		B1	B1+B2	D1	D2	D3	
CRN 155-1-1	11	783	1265	318	204	350	234
CRN 155-1	15	783	1265	318	204	350	245
CRN 155-2-2	22	905	1457	318	204	350	284
CRN 155-2	30	907	1518	396	315	400	387
CRN 155-3-2	37	1029	1665	396	315	400	423
CRN 155-3	45	1052	1760	449	338	450	517
CRN 155-4-1	55	1173	1920	497	410	550	637
CRN 155-5-2	75	1295	2115	551	433	550	764
CRN 155-5	75	1295	2115	551	433	550	764
CRN 155-6	90	1417	2347	551	433	550	854
CRN 155-7	110	1569	2481	616	515	660	1058
CRN 155-8-2	110	1691	2603	616	515	660	1068

CR 185

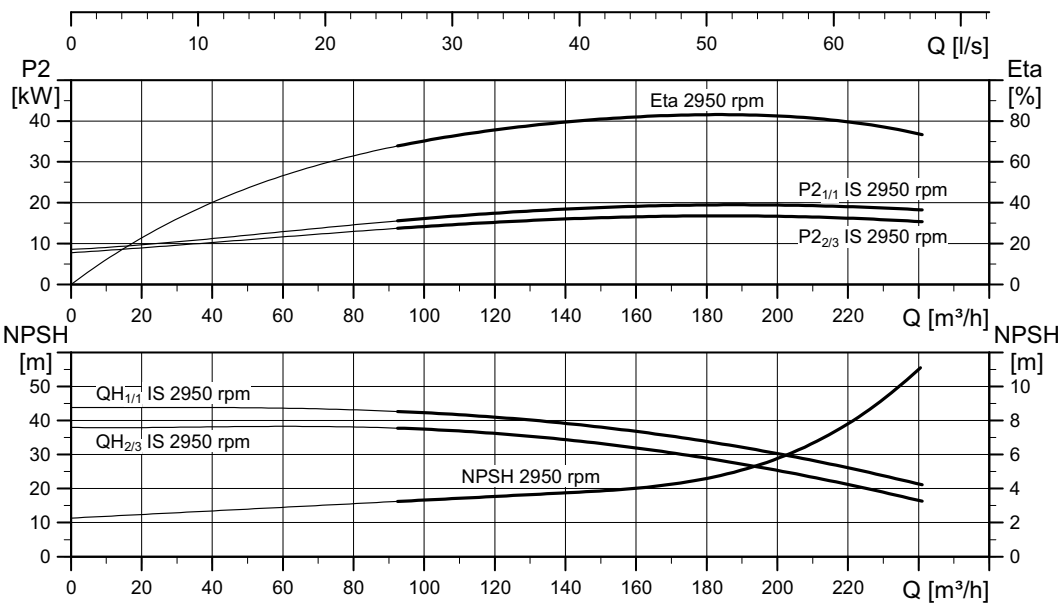
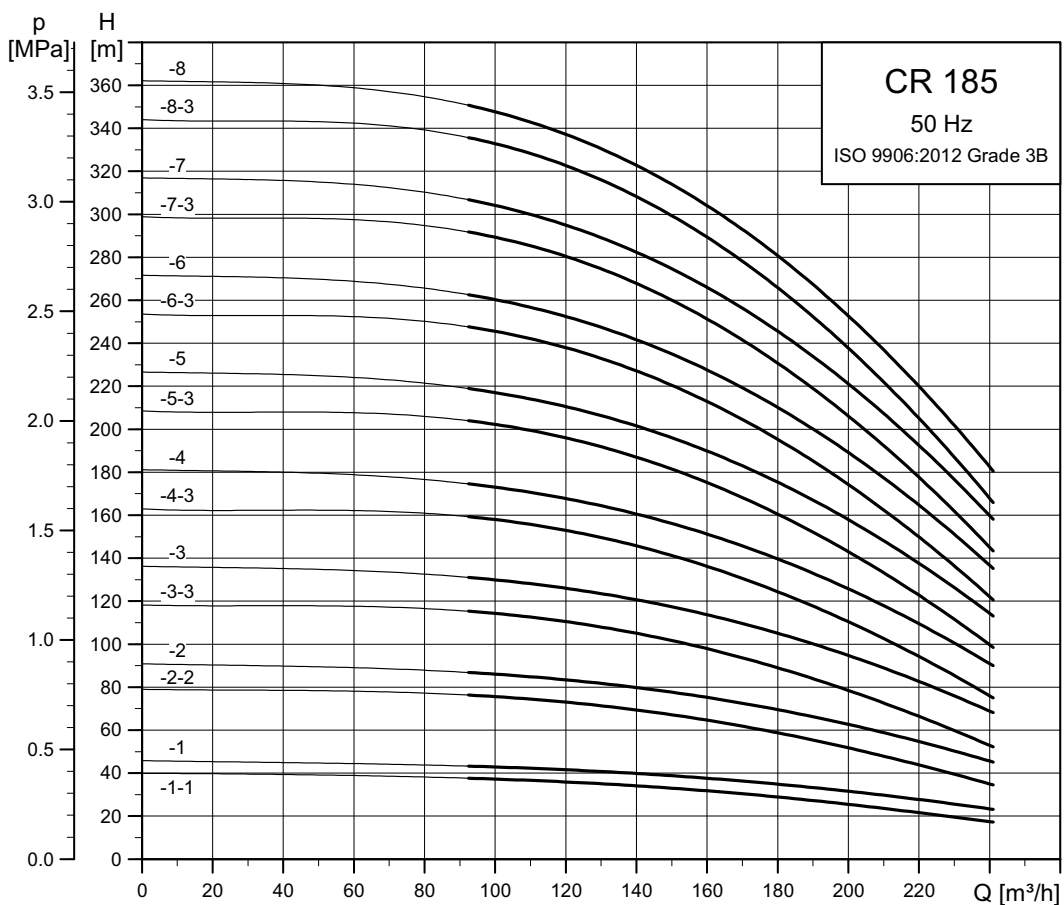

The pump efficiency (ETA) is calculated and based on a three-stage pump.

TM06 5116 0721

Dimensional sketch

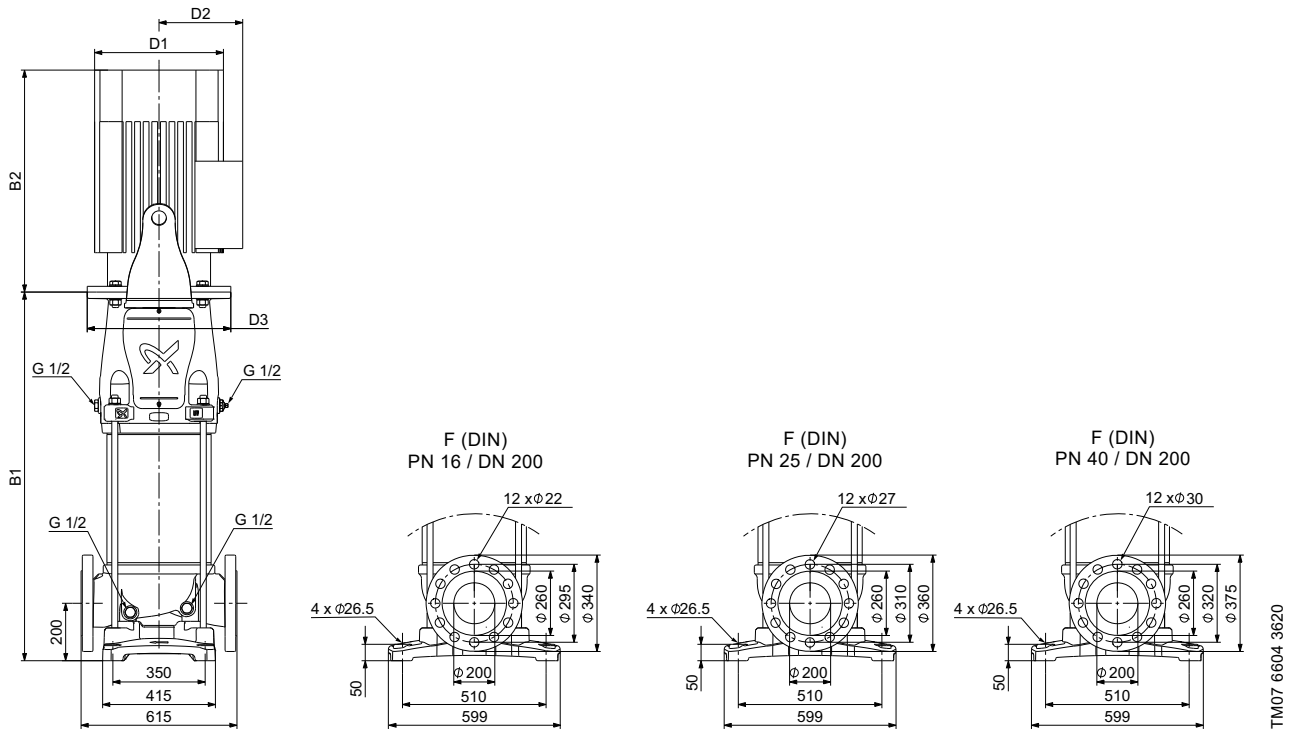

Dimensions and weights

Pump type	Motor P <sub>2</sub> [kW]	CR					Net weight [kg]
		Dimension [mm]					
		B1	B1+B2	D1	D2	D3	
CR 185-1-1	18.5	854	1380	318	204	350	345
CR 185-1	22	854	1406	318	204	350	360
CR 185-2-2	37	986	1622	396	315	400	502
CR 185-2	45	1006	1714	449	338	450	596
CR 185-3-3	55	1140	1887	497	410	550	722
CR 185-3	75	1140	1960	551	433	550	836
CR 185-4-3	75	1268	2088	551	433	550	855
CR 185-4	90	1268	2198	551	433	550	935
CR 185-5-3	110	1420	2332	616	515	660	1135
CR 185-5	110	1420	2332	616	515	660	1135
CR 185-6-3	132	1548	2625	616	515	660	1283
CR 185-6	132	1548	2625	616	515	660	1283
CR 185-7-3	160	1676	2753	616	515	660	1398
CR 185-7	160	1676	2753	616	515	660	1398
CR 185-8-3	200	1804	3036	616	515	660	1583
CR 185-8	200	1804	3036	616	515	660	1583

**CRN 185**

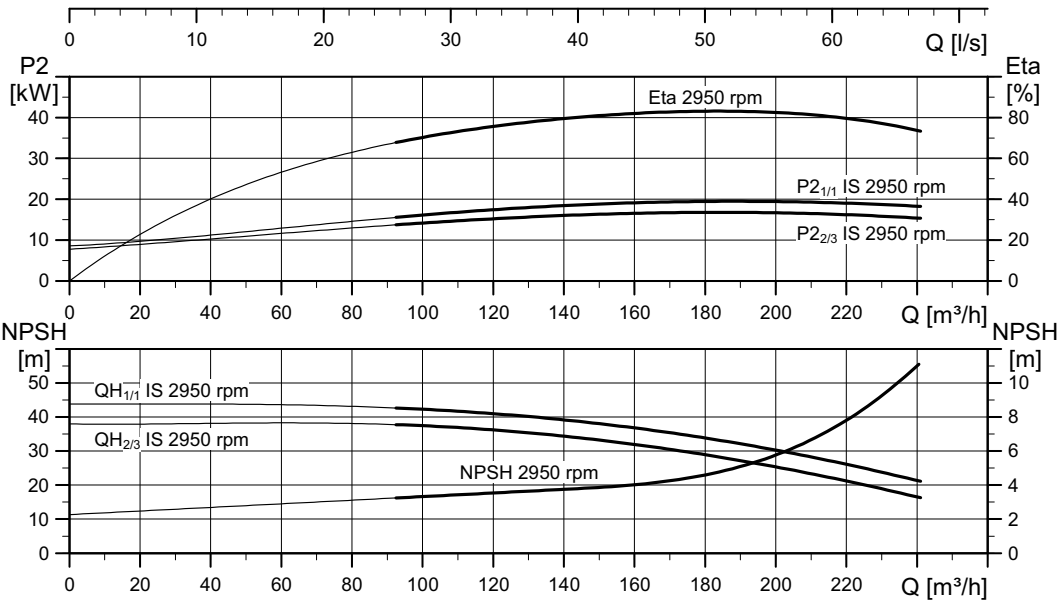
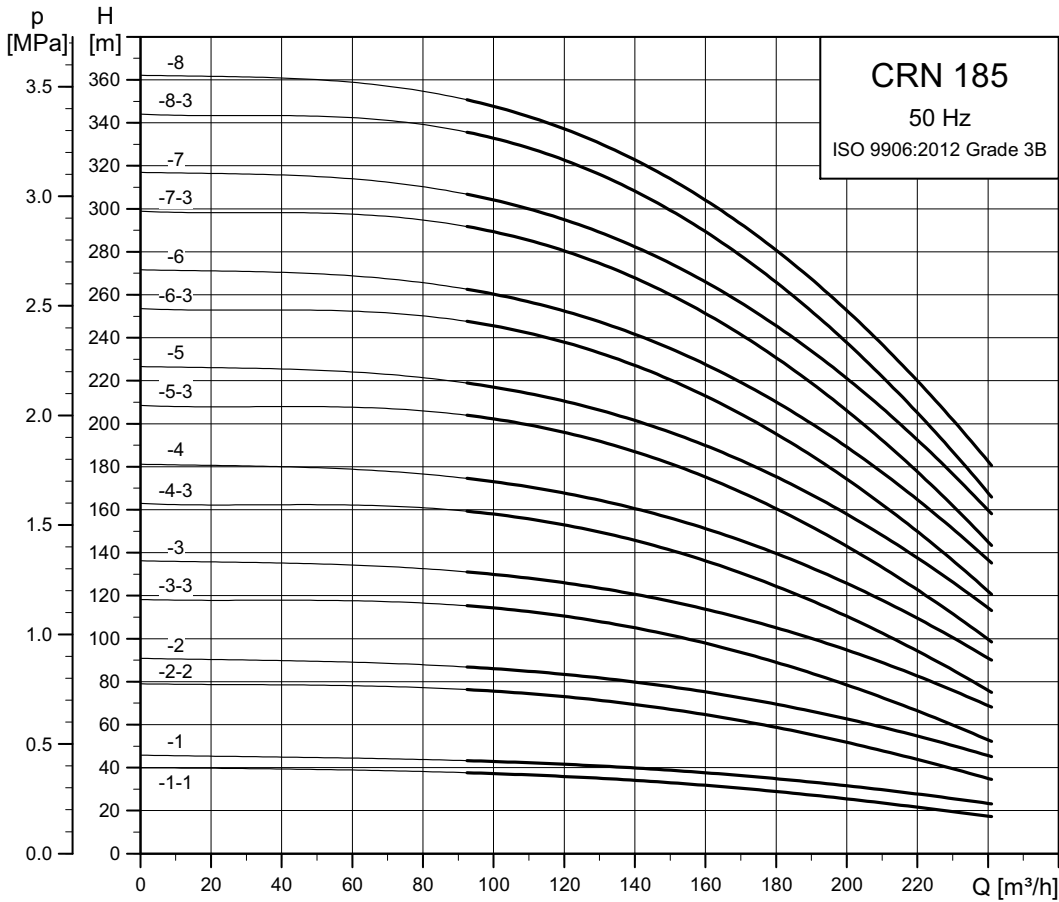

The pump efficiency (ETA) is calculated and based on a three-stage pump.

TM06 5128 0721

Dimensional sketch

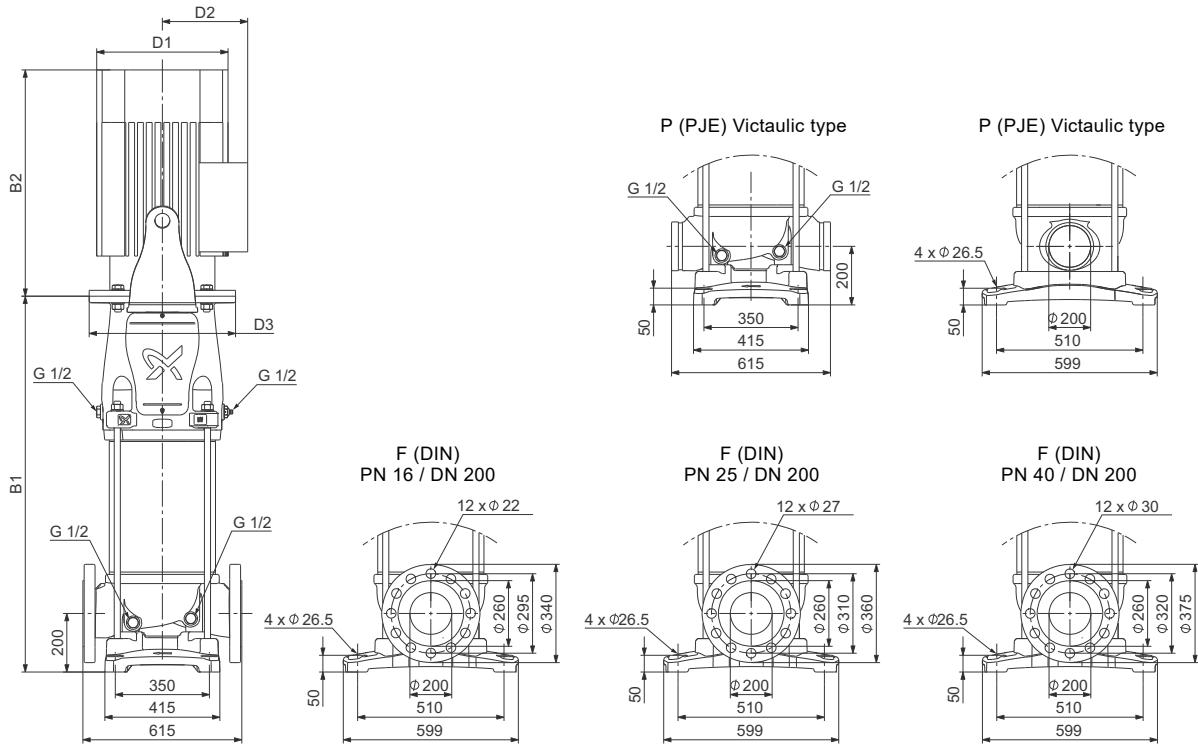

TM07 6605 3620

Dimensions and weights

Pump type	Motor P <sub>2</sub> [kW]	CRN					Net weight [kg]
		Dimension [mm]					
		B1	B1+B2	D1	D2	D3	
CRN 185-1-1	18.5	854	1380	318	204	350	345
CRN 185-1	22	854	1406	318	204	350	360
CRN 185-2-2	37	986	1622	396	315	400	502
CRN 185-2	45	1006	1714	449	338	450	596
CRN 185-3-3	55	1140	1887	497	410	550	722
CRN 185-3	75	1140	1960	551	433	550	836
CRN 185-4-3	75	1268	2088	551	433	550	855
CRN 185-4	90	1268	2198	551	433	550	935
CRN 185-5-3	110	1420	2332	616	515	660	1135
CRN 185-5	110	1420	2332	616	515	660	1135
CRN 185-6-3	132	1548	2625	616	515	660	1283
CRN 185-6	132	1548	2625	616	515	660	1283
CRN 185-7-3	160	1676	2753	616	515	660	1398
CRN 185-7	160	1676	2753	616	515	660	1398
CRN 185-8-3	200	1804	3036	616	515	660	1583
CRN 185-8	200	1804	3036	616	515	660	1583

CR 215

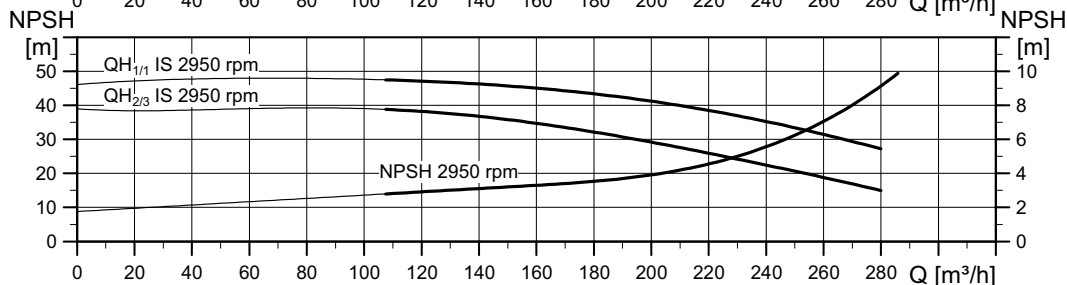
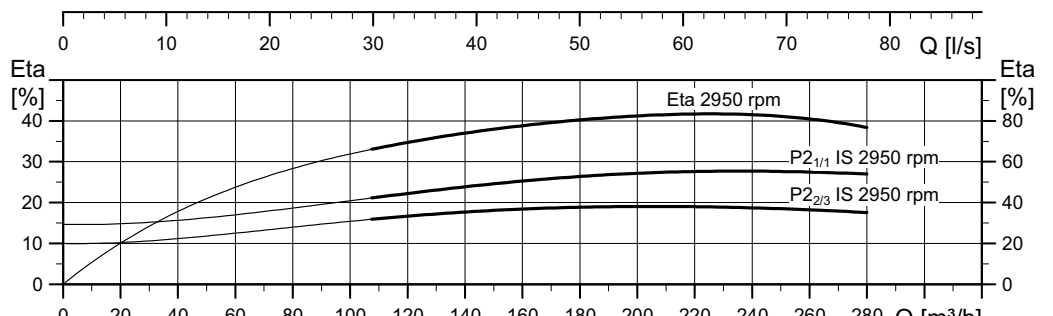
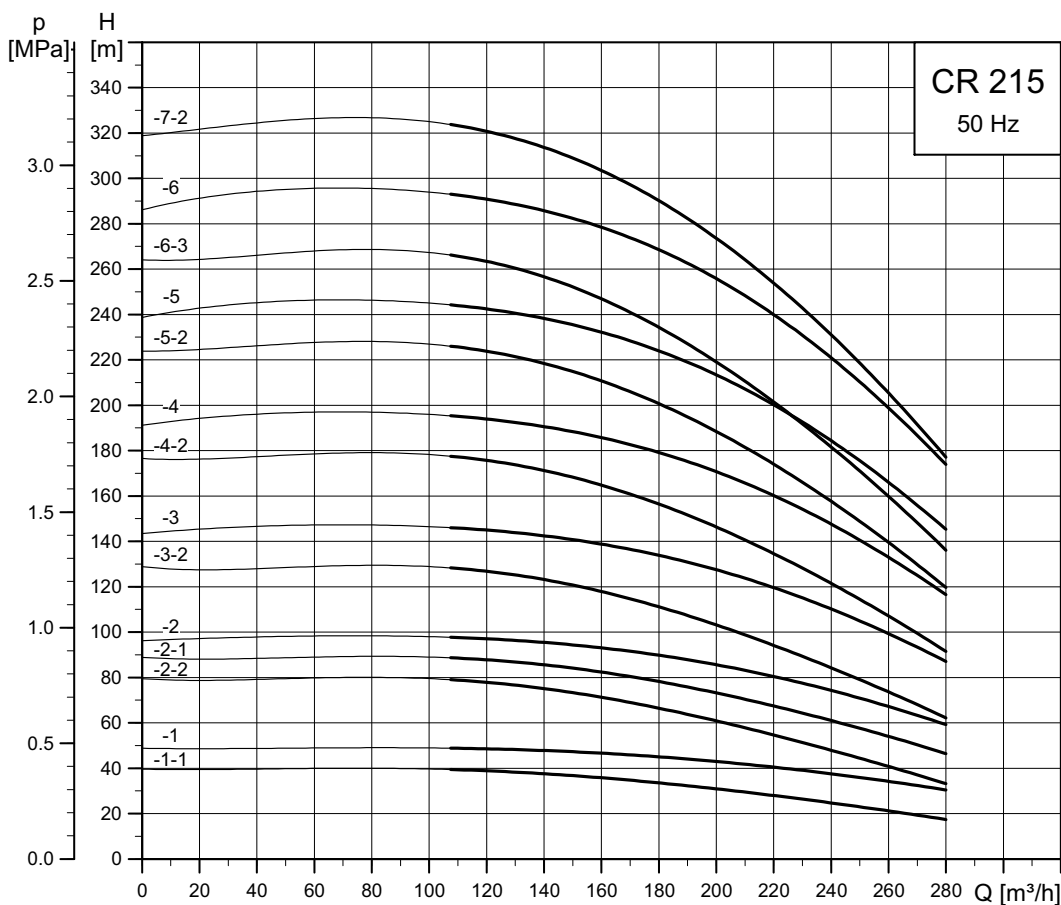

Preliminary performance curves.  
The pump efficiency (ETA) is calculated and based on a three-stage pump.

TM06 5 117 0721

Dimensional sketch

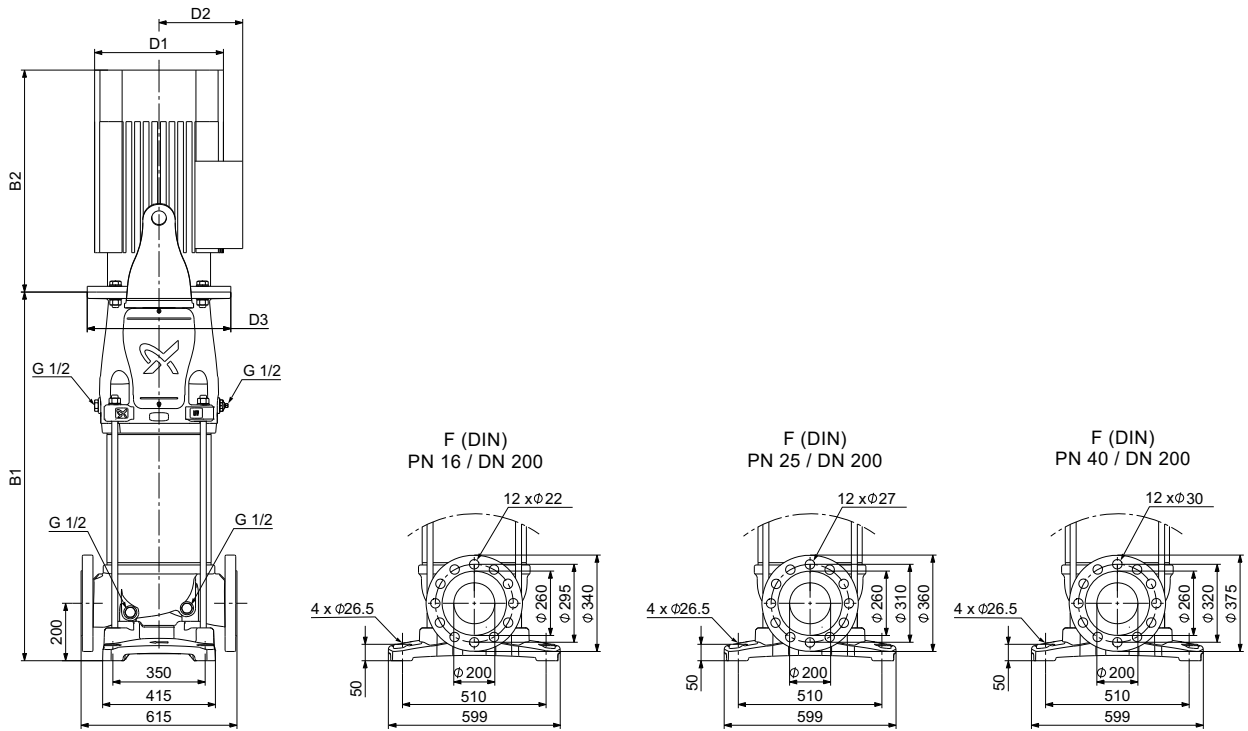

Dimensions and weights

Pump type	Motor P <sub>2</sub> [kW]	CR					Net weight [kg]
		Dimension [mm]					
		B1	B1+B2	D1	D2	D3	
CR 215-1-1	22	854	1406	318	204	350	361
CR 215-1	37	858	1494	396	315	400	488
CR 215-2-2	45	1006	1714	449	338	450	597
CR 215-2-1	55	1012	1759	497	410	550	709
CR 215-2	75	1012	1832	551	433	550	823
CR 215-3-2	75	1140	1960	551	433	550	838
CR 215-3	90	1140	2070	551	433	550	918
CR 215-4-2	110	1292	2204	616	515	660	1124
CR 215-4	132	1292	2369	616	515	660	1254
CR 215-5-2	132	1420	2497	616	515	660	1269
CR 215-5	160	1420	2497	616	515	660	1369
CR 215-6-3	160	1548	2625	616	515	660	1388
CR 215-6	200	1548	2780	616	515	660	1558
CR 215-7-2	200	1676	2908	616	515	660	1573

CRN 215

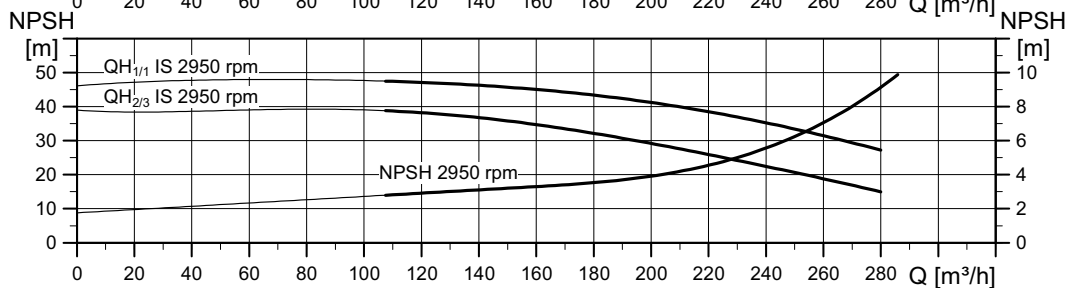
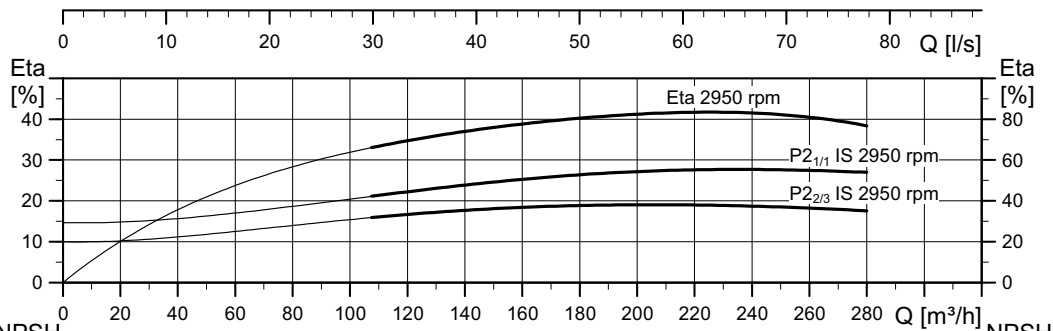
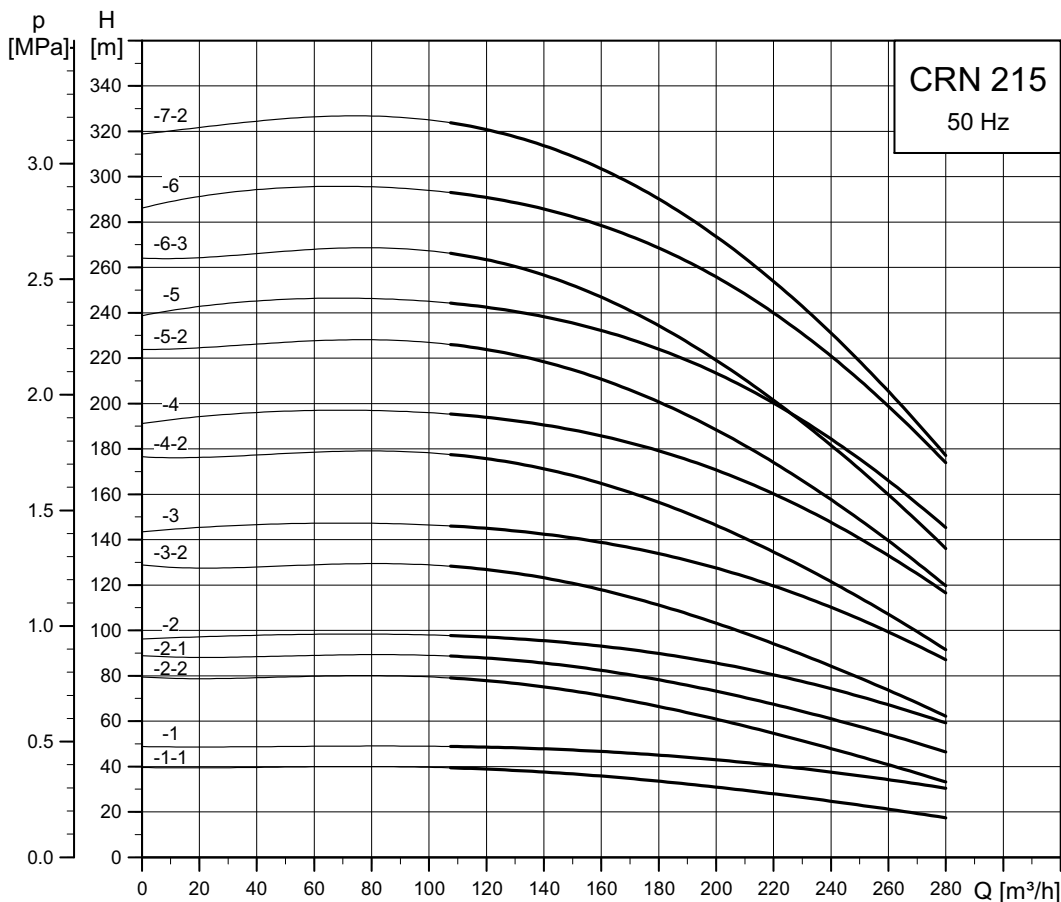

Preliminary performance curves.  
The pump efficiency (ETA) is calculated and based on a three-stage pump.

TM06 5129 0721

Dimensional sketch

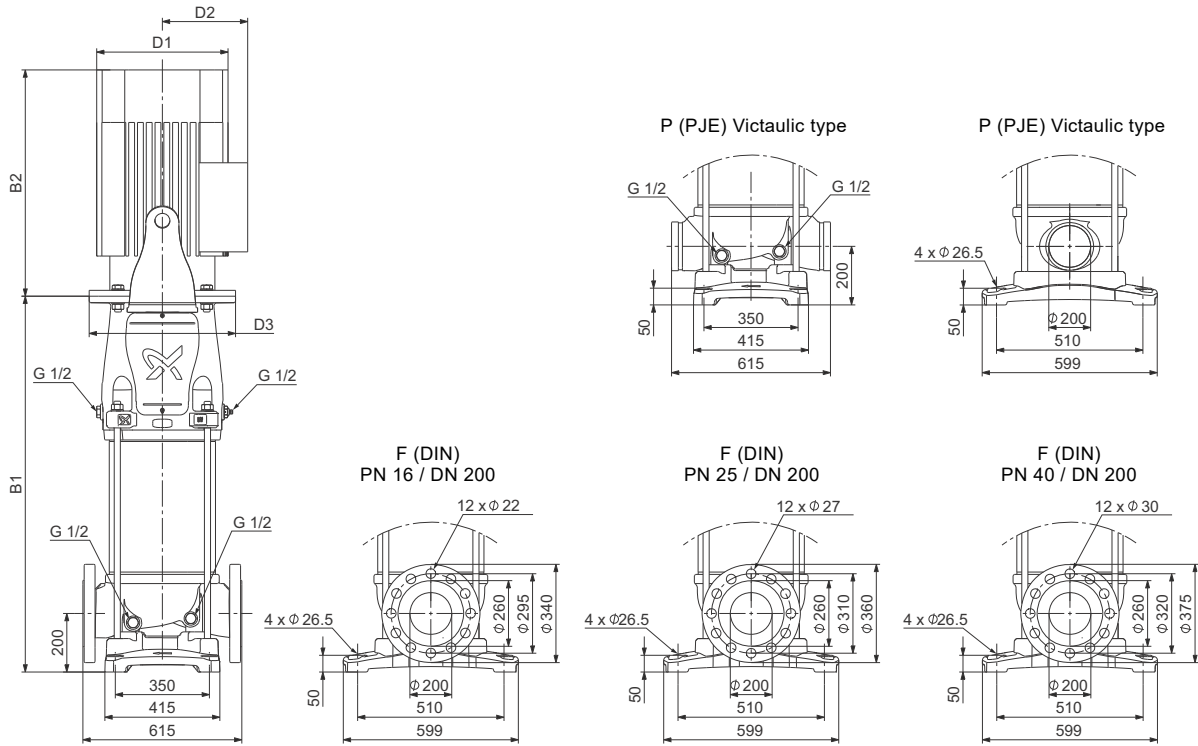

TM07 6605 3620

Dimensions and weights

Pump type	Motor P <sub>2</sub> [kW]	CRN					Net weight [kg]
		Dimension [mm]					
		B1	B1+B2	D1	D2	D3	
CRN 215-1-1	22	854	1406	318	204	350	361
CRN 215-1	37	858	1494	396	315	400	488
CRN 215-2-2	45	1006	1714	449	338	450	597
CRN 215-2-1	55	1012	1759	497	410	550	709
CRN 215-2	75	1012	1832	551	433	550	823
CRN 215-3-2	75	1140	1960	551	433	550	838
CRN 215-3	90	1140	2070	551	433	550	918
CRN 215-4-2	110	1292	2204	616	515	660	1124
CRN 215-4	132	1292	2369	616	515	660	1254
CRN 215-5-2	132	1420	2497	616	515	660	1269
CRN 215-5	160	1420	2497	616	515	660	1369
CRN 215-6-3	160	1548	2625	616	515	660	1388
CRN 215-6	200	1548	2780	616	515	660	1558
CRN 215-7-2	200	1676	2908	616	515	660	1573

## 6. Motor data

### Standard motors for CR, CRI, CRN, 50 Hz

MG



TM03 1711 2805

Motor P2 [kW]	Frame size	Standard voltage [V]	I <sub>1/1</sub> [A]	Cos φ <sub>1/1</sub>	Efficiency class	η [%]	I <sub>start</sub> [%]	Speed [min <sup>-1</sup> ]	Mounting designation
0.37 <sup>1)</sup>	71	220-240Δ / 380-415Y	1.74 / 1.00	0.80 - 0.70	-	78.5	490-530	2850-2880	B14/V18 Tapped-hole flange
0.55 <sup>1)</sup>	71	220-240Δ / 380-415Y	2.50 / 1.44	0.80 - 0.70	-	80.0	580-620	2830-2850	
0.75 <sup>1)</sup>	80	220-240Δ / 380-415Y	3.30 / 1.90	0.81 - 0.71	IE3	80.7	580-620	2840-2870	
1.1 <sup>1)</sup>	80	220-240Δ / 380-415Y	4.35 / 2.50	0.83 - 0.76	IE3	82.7	450-500	2840-2870	
1.5 <sup>1)</sup>	90	220-240Δ / 380-415Y	5.70 / 3.30	0.84 - 0.78	IE3	84.2	750-820	2890-2910	
2.2 <sup>1)</sup>	90	380-415Δ	4.65	0.86 - 0.80	IE3	85.9	840-920	2890-2910	
3 <sup>1)</sup>	100	380-415Δ	6.30	0.87 - 0.82	IE3	87.1	840-920	2900-2920	
4 <sup>2)</sup>	112	380-415Δ	7.90	0.87	IE3	88.1	1000-1110	2920-2940	
5.5 <sup>2)</sup>	132	380-415Δ	11	0.87 - 0.82	IE3	89.2	1080-1180	2920-2940	
7.5 <sup>2)</sup>	132	380-415Δ/660-690Y	14.4 - 14 / 8.30 - 8.10	0.88 - 0.82	IE3	90.4	780-910	2910-2920	
11 <sup>2)</sup>	160	380-415Δ/660-690Y	20.8 - 19.8 / 12 - 11.8	0.88 - 0.84	IE3	91.2	660-780	2940-2950	
15 <sup>2)</sup>	160	380-415Δ/660-690Y	28-26 / 16.2 - 15.6	0.89 - 0.87	IE3	91.9	660-780	2930-2950	
18.5 <sup>2)</sup>	160	380-415Δ/660-690Y	34.5 - 32.5 / 20 - 18.8	0.89 - 0.85	IE3	92.4	830-980	2940-2950	
22 <sup>2)</sup>	180	380-415Δ/660-690Y	39.5 / 22.8	0.90	IE3	92.7	830-830	2950	

Siemens



TM03 1710 2805

30 <sup>2)</sup>	200	380-420Δ/660-725Y	56-52 / 32.5 - 30	0.86	IE3	93.3	780-780	2955	B5/V1 Free-hole flange
37 <sup>2)</sup>	200	380-420Δ/660-725Y	68-63 / 39 - 36.5	0.86	IE3	93.7	760-760	2950	
45 <sup>2)</sup>	225	380-420Δ/660-725Y	81-75 / 47 - 43.5	0.89	IE3	94	730-730	2960	
55 <sup>2)</sup>	250	380-420Δ/660-725Y	99-91/57-53	0.89	IE3	94.3	700-700	2975	
75 <sup>1)</sup>	280	380-420Δ/660-725Y	134-126/77-72	0.89	IE3	94.7	680-680	2975	
90 <sup>1)</sup>	280	380-420Δ/660-725Y	160-148/92-85	0.90	IE3	95	720-720	2975	
110 <sup>1)</sup>	315	380-420Δ/660-725Y	192-176/110-102	0.91	IE3	95.2	710-710	2980	
132 <sup>1)</sup>	315	380-420Δ/660-725Y	230-210/133-121	0.91	IE3	95.4	720-720	2980	
160 <sup>1)</sup>	315	380-420Δ/660-725Y	280-255/161-147	0.92	IE3	95.6	780-780	2982	
200 <sup>1)</sup>	315	380-420Δ/660-725Y	345-310/199-179	0.92	IE3	95.8	720-720	2982	

1) Deep-groove ball bearings

2) Angular contact bearing mounted in drive end

## 7. List of pumped liquids

A number of typical liquids are listed below.

Other pump versions may be applicable, but those stated in the list are considered to be the best choices.

The table is intended as a general guide only and cannot replace actual testing of the pumped liquids and pump materials under specific working conditions.

Therefore, use the list with some caution. Factors such as those mentioned below may affect the chemical resistance of a specific pump version:

- concentration of the pumped liquid
- liquid temperature
- pressure.

Take safety precautions when pumping dangerous liquids.

### Notes

<b>D</b>	Often with additives.
	The density and/or viscosity differ from that/those of water.
<b>E</b>	Take this factor into account when calculating motor output and pump performance.
<b>F</b>	Pump selection depends on many factors. Contact Grundfos.
<b>H</b>	Risk of crystallisation/precipitation in shaft seal.
<b>1</b>	Highly flammable liquid.
<b>2</b>	Combustible liquid.
<b>3</b>	Insoluble in water.
<b>4</b>	Low self-ignition point.

Pumped liquid	Chemical formula	Note	Liquid concentration, liquid temperature	CR	CRN
Acetic acid	CH <sub>3</sub> COOH	-	5 %, 20 °C	-	HQQE
Acetone	CH <sub>3</sub> COCH <sub>3</sub>	1, F	100 %, 20 °C	-	HQQE
Alkaline degreasing agent		D, F	-	HQQE	-
Ammonium bicarbonate	NH <sub>4</sub> HCO <sub>3</sub>	E	20 %, 30 °C	-	HQQE
Ammonium hydroxide	NH <sub>4</sub> OH	-	20 %, 40 °C	HQQE	-
Aviation fuel		1, 3, 4, F	100 %, 20 °C	HQBv	-
Benzoic acid	C <sub>6</sub> H <sub>5</sub> COOH	H	0.5 %, 20 °C	-	HQQV
Boiler water		-	< 120 °C	HQQE	-
		F	120-180 °C	-	-
Calcareous water		-	< 90 °C	HQQE	-
Calcium acetate (as coolant with inhibitor)	Ca(CH <sub>3</sub> COO) <sub>2</sub>	D, E	30 %, 50 °C	HQQE	-
Calcium hydroxide	Ca (OH) <sub>2</sub>	E	Saturated solution, 50 °C	HQQE	-
Chloride-containing water		F	< 30 °C, maximum 500 ppm	-	HQQE
Chromic acid	H <sub>2</sub> CrO <sub>4</sub>	H	1 %, 20 °C	-	HQQV
Citric acid	HOC(CH <sub>2</sub> CO <sub>2</sub> H) <sub>2</sub> COOH	H	5 %, 40 °C	-	HQQE
Completely desalinated water (demineralised water)		-	120 °C	-	HQQE
Condensate		-	120 °C	HQQE	-
Copper sulphate	CuSO <sub>4</sub>	E	10 %, 50 °C	-	HQQE
Corn oil		D, E, 3	100 %, 80 °C	HQQV	-
Diesel oil		2, 3, 4, F	100 %, 20 °C	HQBv	-
Domestic hot water (potable water)		-	< 120 °C	HQQE	-
Ethanol (ethyl alcohol)	C <sub>2</sub> H <sub>5</sub> OH	1, F	100 %, 20 °C	HQQE	-
Ethylene glycol	HOCH <sub>2</sub> CH <sub>2</sub> OH	D, E	50 %, 50 °C	HQQE	-
Formic acid	HCOOH	-	5 %, 20 °C	-	HQQE
Glycerine (glycerol)	OHCH <sub>2</sub> CH(OH)CH <sub>2</sub> OH	D, E	50 %, 50 °C	HQQE	-
Hydraulic oil (mineral)		E, 2, 3	100 %, 100 °C	HQQV	-
Hydraulic oil (synthetic)		E, 2, 3	100 %, 100 °C	HQQV	-
Isopropyl alcohol	CH <sub>3</sub> CHOHCH <sub>3</sub>	1, F	100 %, 20 °C	HQQE	-
Lactic acid	CH <sub>3</sub> CH(OH)COOH	E, H	10 %, 20 °C	-	HQQV
Linoleic acid	C <sub>17</sub> H <sub>31</sub> COOH	E, 3	100 %, 20 °C	HQQV	-
Methanol (methyl alcohol)	CH <sub>3</sub> OH	1, F	100 %, 20 °C	HQQE	-
Motor oil		E, 2, 3	100 %, 80 °C	HQQV	-
Naphthalene	C <sub>10</sub> H <sub>8</sub>	E, H	100 %, 80 °C	HQQV	-
Nitric acid	HNO <sub>3</sub>	F	1 %, 20 °C	-	HQQE
Oil-containing water		-	< 100 °C	HQQV	-
Olive oil		D, E, 3	100 %, 80 °C	HQQV	-
Oxalic acid	(COOH) <sub>2</sub>	H	1 %, 20 °C	-	HQQE
Ozone-containing water	(O <sub>3</sub> )	-	< 100 °C	-	HQQE
Peanut oil		D, E, 3	100 %, 80 °C	HQQV	-
Petrol		1, 3, 4, F	100 %, 20 °C	HQBv	-
Phosphoric acid	H <sub>3</sub> PO <sub>4</sub>	E	20 %, 20 °C	-	HQQE
Propanol	C <sub>3</sub> H <sub>7</sub> OH	1, F	100 %, 20 °C	HQQE	-
Propylene glycol	CH <sub>3</sub> CH(OH)CH <sub>2</sub> OH	D, E	50 %, 90 °C	HQQE	-
Potassium carbonate	K <sub>2</sub> CO <sub>3</sub>	E	20 %, 50 °C	HQQE	-
Potassium formate (as coolant with inhibitor)	KOOCH	D, E	30 %, 50 °C	HQQE	-
Potassium hydroxide	KOH	E	20 %, 50 °C	-	HQQE
Potassium permanganate	KMnO <sub>4</sub>	-	5 %, 20 °C	-	HQQE
Rape seed oil		D, E, 3	100 %, 80 °C	HQQV	-
Salicylic acid	C <sub>6</sub> H <sub>4</sub> (OH)COOH	H	0.1 %, 20 °C	-	HQQE
Silicone oil		E, 3	100 %	HQQV	-
Sodium bicarbonate	NaHCO <sub>3</sub>	E	10 %, 60 °C	-	HQQE
Sodium chloride (as coolant)	NaCl	D, E	30 %, < 5 °C, pH > 8	HQQE	-
Sodium hydroxide	NaOH	E	20 %, 50 °C	-	HQQE
Sodium hypochlorite	NaOCl	F	0.1 %, 20 °C	-	HQQV
Sodium nitrate	NaNO <sub>3</sub>	E	10 %, 60 °C	-	HQQE
Sodium phosphate	Na <sub>3</sub> PO <sub>4</sub>	E, H	10 %, 60 °C	-	HQQE
Sodium sulphate	Na <sub>2</sub> SO <sub>4</sub>	E, H	10 %, 60 °C	-	HQQE
Softened water		-	< 120 °C	-	HQQE
Soya oil		D, E, 3	100 %, 80 °C	HQQV	-
Sulphuric acid	H <sub>2</sub> SO <sub>4</sub>	F	1 %, 20 °C	-	HQQV
Sulphurous acid	H <sub>2</sub> SO <sub>3</sub>	-	1 %, 20 °C	-	HQQE
Unsalted swimming-pool water		-	Approx. 2 ppm free chlorine (Cl <sub>2</sub> )	HQQE	-

## 8. Accessories

### Pipe connection

Various sets of counterflanges and couplings are available for pipe connection.

#### Counterflanges for CR

A set consists of one counterflange, one gasket, bolts and nuts.

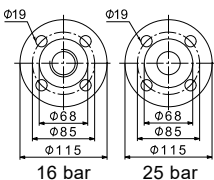
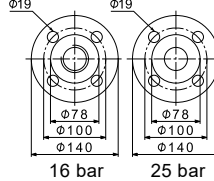
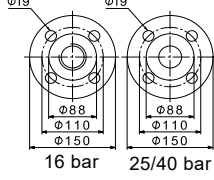
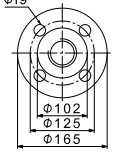
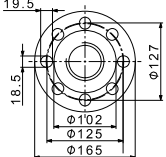
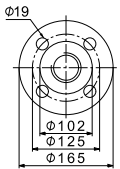
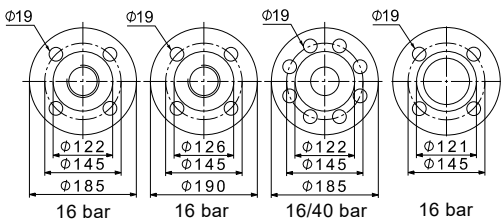
Counterflange	Pump type	Description	Rated pressure	Pipe connection	Product number
 16 bar      25 bar	TM05 0998 2011 <b>CR 1s</b> <b>CR 1</b> <b>CR 3</b> <b>CR 5</b>	Threaded	16 bar, EN 1092-2	Rp 1	409901
		For welding	25 bar, EN 1092-2	25 mm, nominal	409902
 16 bar      25 bar	TM05 1003 2011 <b>CR 1s</b> <b>CR 1</b> <b>CR 3</b> <b>CR 5</b>	Threaded	16 bar, EN 1092-2	Rp 1 1/4	419901
		For welding	25 bar, EN 1092-2	32 mm, nominal	419902
 16 bar      25/40 bar	TM05 1002 2011 <b>CR 10</b>	Threaded	16 bar, EN 1092-2	Rp 1 1/2	429902
		Threaded	16 bar, EN 1092-2	Rp 2	429904
		For welding	25 bar, EN 1092-2	40 mm, nominal	429901
		For welding	40 bar, special flange	50 mm, nominal	429903
	TM05 0999 2011	Threaded	16 bar, EN 1092-2	Rp 2	339903
		Threaded	16 bar, special flange	Rp 2 1/2	339904
	TM05 1005 2011 <b>CR 15</b> <b>CR 20</b>	Threaded	16 bar, special flange	Rp 2 1/2*	96509578
		For welding	25 bar, EN 1092-2	50 mm, nominal	339901
	TM05 0999 2011	For welding	40 bar, special flange	65 mm, nominal	339902
		For welding	16 bar, EN 1092-2	Rp 2 1/2	349902
 16 bar      16 bar      16/40 bar      16 bar	TM05 0997 2011 <b>CR 32</b>	Threaded	16 bar, EN 1092-2	Rp 3	349901
		Threaded	16 bar, special flange	Rp 3	349901
		For welding	16 bar, EN 1092-2	65 mm, nominal	349904
		For welding	40 bar, DIN 2635	65 mm, nominal	349905
		For welding	16 bar, special flange	80 mm, nominal	349903

Counterflange	Pump type	Description	Rated pressure	Pipe connection	Product number
	TM05 0996 2011 <b>CR 45</b>	Threaded	16 bar	Rp 3	350540
		For welding	16 bar	80 mm, nominal	350541
		For welding	40 bar	80 mm, nominal	350542
	TM05 0995 2011 <b>CR 64</b>	Threaded	16 bar, EN 1092-2	Rp 4	369901
		For welding	16 bar, EN 1092-2	100 mm, nominal	369902
		For welding	25 bar, EN 1092-2	100 mm, nominal	369905
	TM06 5157 2520 <b>CR 95</b>	For welding	16 bar, EN 1092-2	100 mm, nominal	99432754
		For welding	25/40 bar, EN 1092-2	100 mm, nominal	99432755
	TM03 8891 2520 - TM06 5171 25202520 <b>CR 125</b> <b>CR 155</b>	For welding	16 bar, EN 1563	150 mm, nominal	99432761
		For welding	25/40 bar, EN 1563	150 mm, nominal	99432760
	TM06 5172 2520 - TM06 5173 2520 - TM06 5156 2520 <b>CR 185</b> <b>CR 215</b>	For welding	16 bar, EN 1563	200 mm, nominal	97521270
		For welding	25 bar, EN 1563	200 mm, nominal	97739724
		For welding	40 bar, EN 1563	200 mm, nominal	97521269

\* Flange with 20 mm higher collar. With this collar, the installation dimensions of a CR 20 will be identical to those of a CR 32. If a CR 32 is replaced by a CR 20, the base must be raised by 15 mm.

### Counterflanges for CRN

Counterflanges for CRN pumps are made of stainless steel EN 1.4401 (≈ AISI 316).

A set consists of one counterflange, one gasket, bolts and nuts.

Counterflange	Pump type	Description	Rated pressure	Pipe connection	Product number
	TM05 0998 2011 <b>CRN 1s</b> <b>CRN 1</b> <b>CRN 3</b> <b>CRN 5</b>	Threaded	16 bar, EN 1092-1	Rp 1	405284
		For welding	25 bar, EN 1092-1	25 mm, nominal	405285
	TM05 1003 2011 <b>CRN 1s</b> <b>CRN 1</b> <b>CRN 3</b> <b>CRN 5</b>	Threaded	16 bar, EN 1092-1	Rp 1 1/4	415304
		For welding	25 bar, EN 1092-1	32 mm, nominal	415305
	TM05 1001 2011	Threaded	16 bar, EN 1092-1	Rp 1 1/2	425245
	TM05 1006 2011	Threaded	16 bar, EN 1092-1	Rp 2	96509570
	TM05 1001 2011	For welding	25 bar, EN 1092-1	40 mm, nominal	425246
	TM05 1006 2011	For welding	25 bar, special flange	50 mm, nominal	96509571

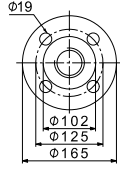
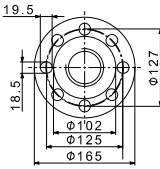
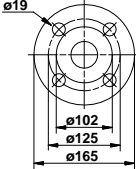
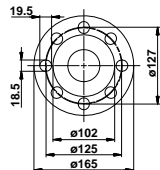
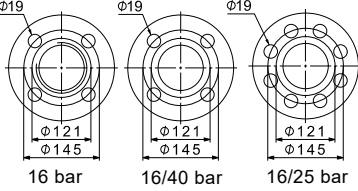
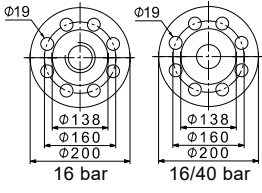
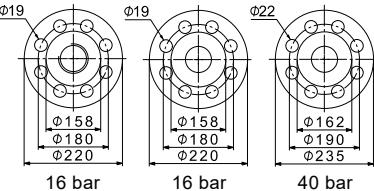
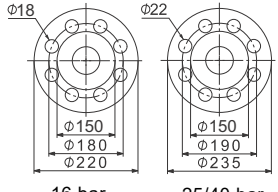
Counterflange	Pump type	Description	Rated pressure	Pipe connection	Product number
	TM05 0999 2011	Threaded	16 bar, EN 1092-1	Rp 2	335254
	TM05 1005 2011	Threaded	16 bar, special flange	Rp 2 1/2	96509575
	TM03 0402 2011	For welding	25 bar, EN 1092-1	50 mm, nominal	335255
	TM00 7203 2803	For welding	25 bar, special flange	65 mm, nominal	96509573
	TM05 0994 2011	Threaded	16 bar	Rp 2 1/2	349910
		Threaded	16 bar, special flange	Rp 3	349911
		For welding	16 bar	65 mm, nominal	349906
		For welding	40 bar	65 mm, nominal	349908
	TM05 0996 2011	Threaded	16 bar	Rp 3	350543
		For welding	16 bar	80 mm, nominal	350544
		For welding	40 bar	80 mm, nominal	350545
	TM05 0995 2011	Threaded	16 bar	Rp 4	369904
		For welding	16 bar	100 mm, nominal	369903
		For welding	40 bar	100 mm, nominal	369906
	TM06 5157 2520	For welding	16 bar, EN 1.4408	100 mm, nominal	99432731
		For welding	25/40 bar, EN 1.4408	100 mm, nominal	99432732

Counterflange	Pump type	Description	Rated pressure	Pipe connection	Product number
<p>16 bar      25/40 bar</p>	TM03 8891 2520 - TM06 5171 2520 <b>CRN 125</b> <b>CRN 155</b>	For welding	16 bar, EN 1.4408	150 mm, nominal	99432733
		For welding	25/40 bar, EN 1.4408	150 mm, nominal	99432734
<p>16 bar      25 bar      40 bar</p>	TM06 5172 2520 - TM06 5173 2520 - TM06 5156 2520 <b>CRN 185</b> <b>CRN 215</b>	For welding	16 bar, EN 1.4408	200 mm, nominal	99432735
		For welding	25 bar, EN 1.4408	200 mm, nominal	99432736
		For welding	40 bar, EN 1.4408	200 mm, nominal	99432737

## PJE couplings for CRN

Materials in contact with the pumped liquid are made of stainless steel EN 1.4401 ( $\approx$  AISI 316) and rubber.

A set consists of two coupling halves (Victaulic type 77), one gasket, one pipe stub (for welding or threaded), bolts and nuts.

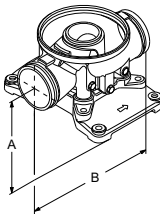
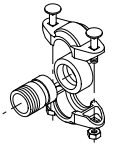
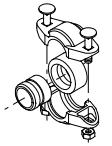
Coupling	Pump type	Pipe stub	Maximum pressure [bar]	A	B	Pipe connection	Rubber parts	Number of coupling sets required	Product number	
  	<b>CRN 1s</b> <b>CRN 1</b> <b>CRN 3</b> <b>CRN 5</b>	Threaded	69	50	320	R 1 1/4	EPDM	2	419911	
								FKM	2	419905
			For welding	69	50	280	DN 32	EPDM	2	419912
								FKM	2	419904
		<b>CRN 10</b> <b>CRN 15</b> <b>CRN 20</b>	Threaded	69	80	377	R 2	EPDM	2	339911
									FKM	2
			For welding	69	80	371	DN 50	EPDM	2	339910
								FKM	2	339917
		<b>CRN 32</b>	For welding	69	105	420	DN 80	EPDM	2	98144746
								FKM	2	98144749
	<b>CRN 45</b> <b>CRN 64</b>	For welding	69	140	465	DN 100	EPDM	2	98144752	
							FKM	2	98144755	
	<b>CRN 95</b>	For welding	69	140	465	DN 100	EPDM	2	98144752	
							FKM		98144755	

TM06 9172 1817 - TM00 3808 1094

### FlexiClamp base connections

All sets comprise the necessary number of bolts and nuts as well as a gasket or O-ring.

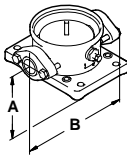
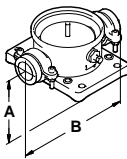
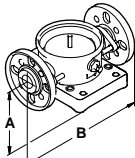
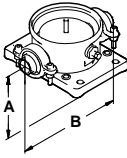
Base connection	Pump type	Connection	Pipe connection	PN	A	B	Rubber parts	Number of coupling sets required	Product number
	TM02 7368 3303 <b>CRI CRN</b> 1s, 1, 3, 5	Oval (cast iron)	Rp 1	16	50	210	Klingersil	1	96449748
			Rp 1 1/4					1	96449749
		Oval (stainless steel)	Rp 1					2	96449746
			Rp 1 1/4					2	96449747
	TM02 7369 3303 <b>CRI CRN</b> 1s, 1, 3, 5	Union	G 2	25	50	228	EPDM	2	96449743
							FKM	2	96449744
	TM02 7370 3303 <b>CRI CRN</b> 1s, 1, 3, 5	DIN (stainless steel)	DN 25	16	75	250	EPDM	2	96449745
			DN 32				FKM	2	96449900
	TM02 7371 3303 <b>CRI CRN</b> 1s, 1, 3, 5	Clamp, threaded pipe stub	Rp 1	25	50	208	EPDM	2	405280
			FKM				2	405281	
			Rp 1 1/4				EPDM	2	415296
			1" NPT				FKM	2	415297
			1 1/4" NPT				EPDM	2	405291
							FKM	2	405292
							EPDM	2	415311
							FKM	2	415312
			Clamp, pipe stub for welding				EPDM	2	405282
							FKM	2	405283
	EPDM	2	415300						
	FKM	2	415301						

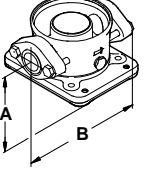
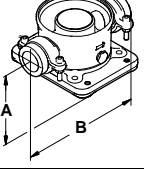
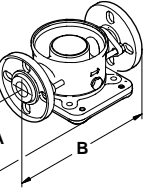
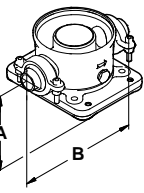
Base connection	Pump type	Connection	Pipe connection	PN	A	B	Rubber parts	Number of coupling sets required	Product number	
	<b>CRI 10</b> <b>CRN 10</b>	Oval (cast iron)	Rp 1 1/4	16	80	260	Klingersil	2	96498775	
			Rp 1 1/2					2	96498727	
			Rp 2					2	96498836	
			Rp 1 1/4					2	96498776	
			Oval (stainless steel)					Rp 1 1/2	2	96498728
			Rp 2					2	96498835	
	<b>CRI 10</b> <b>CRN 10</b>	Union	G 2 3/4	25	80	288	EPDM	2	96500275	
							FKM	2	96500276	
	<b>CRI 10</b> <b>CRN 10</b>	FGJ (cast iron)	DN 40	16	80	316	EPDM	2	96498840	
							FKM	2	96500119	
		FGJ (stainless steel)	DN 50				EPDM	2	96500263	
		FKM					2	96500264		
		FGJ (cast iron)					EPDM	2	96500265	
		FKM					2	96500266		
FGJ (stainless steel)	EPDM	2	96500267							
FKM	2	96500269								
	<b>CRI 10</b> <b>CRN 10</b>	Clamp, threaded pipe stub	Rp 1 1/2	25	80	346	EPDM	2	425238	
			FKM				2	425239		
			Rp 2				259	EPDM	2	335241
			FKM				2	335242		
			Rp 2 1/2				EPDM	2	96508600	
			FKM				2	96508601		
			48.3 (DN 40)				EPDM	2	425242	
			FKM				2	425243		
			60.3 (DN 50)				EPDM	2	335251	
			FKM				2	335252		

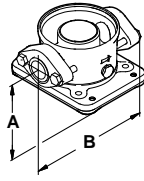
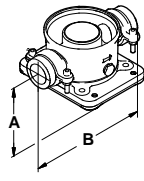
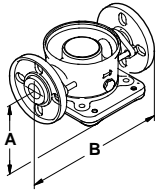
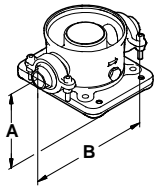
Base connection	Pump type	Connection	Pipe connection	PN	A	B	Rubber parts	Number of coupling sets required	Product number	
	<b>CRI 15, 20</b> <b>CRN 15, 20</b> TM02 7372 3303	Oval (cast iron)	Rp 1 1/4	10	90	260	Klingersil	2	96498775	
			Rp 1 1/2					2	96498727	
			Rp 2					2	96498836	
			Rp 1 1/4					2	96498776	
			Rp 1 1/2					2	96498728	
			Rp 2					2	96498835	
	<b>CRI 15, 20</b> <b>CRN 15, 20</b> TM02 7374 3303	Union	G 2 3/4	25	90	288	EPDM	2	96500275	
							FKM	2	96500276	
	<b>CRI 15, 20</b> <b>CRN 15, 20</b> TM02 7373 3303	FGJ (cast iron)	DN 40	10	90	334	EPDM	2	96498840	
							FKM	2	96500119	
							FGJ (stainless steel)	EPDM	2	96500263
								FKM	2	96500264
							FGJ (cast iron)	EPDM	2	96500265
								FKM	2	96500266
FGJ (stainless steel)	EPDM	2	96500267							
	FKM	2	96500269							
	<b>CRI 15, 20</b> <b>CRN 15, 20</b> TM02 7375 3303	Clamp, threaded pipe stub	Rp 1 1/2	25	90	346	EPDM	2	425238	
			FKM				2	425239		
			Rp 2				EPDM	2	335241	
							FKM	2	335242	
			Rp 2 1/2				EPDM	2	96508600	
							FKM	2	96508601	
			48.3 (DN 40)				EPDM	2	425242	
							FKM	2	425243	
Clamp, pipe stub for welding	EPDM	2	335251							
	FKM	2	335252							

## LiqTec

The LiqTec dry-running protection unit protects the pump and process against dry running and temperatures exceeding  $130 \pm 5$  °C. Connected to the motor PTC sensor, LiqTec also monitors the motor temperature.

LiqTec is prepared for DIN rail mounting in control cabinets.

Enclosure class: IPX0.

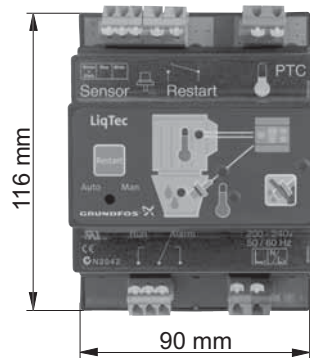

TM03 2108 3705

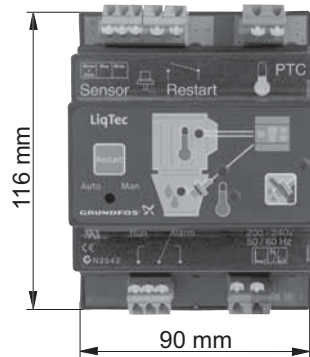
LiqTec unit	Pump type	Voltage [V]	LiqTec	Sensor 1/2"	Cable 5 m	Extension cable 15 m	Product number
	<b>CR</b> <b>CRI</b> <b>CRN</b>	200-240	•	•	•	-	96556429
		80-130	•	•	•	-	96556430
		-	-	-	-	•	96443676

## Sensors

Sensor	Type	Supplier	Measuring range	Product number
Flowmeter	SITRANS FM MAGFLO MAG 5100 W	Siemens	1-5 m <sup>3</sup> (DN 25)	ID8285
	SITRANS FM MAGFLO MAG 5100 W		3-10 m <sup>3</sup> (DN 40)	ID8286
	SITRANS FM MAGFLO MAG 5100 W		6-30 m <sup>3</sup> (DN 65)	ID8287
	SITRANS FM MAGFLO MAG 5100 W		20-75 m <sup>3</sup> (DN 100)	ID8288
Temperature sensor	TTA (0) 25	Carlo Gavazzi	0-25 °C	96432591
	TTA (-25) 25		-25 to +25 °C	96430194
	TTA (50) 100		50-100 °C	96432592
	TTA (0) 150		0-150 °C	96430195
Accessory for temperature sensor. All with 1/2 RG connection	Protecting tube Ø9 x 50 mm			96430201
	Protecting tube Ø9 x 100 mm			96430202
	Cutting ring bush			96430203
Temperature sensor, ambient temperature	WR 52	tmg (DK: Plesner)	-50 to +50 °C	ID8295
Differential-temperature sensor	ETSD	Honsberg	0-20 °C	96409362
	ETSD		0-50 °C	96409363

**Note:** All sensors have 4-20 mA signal output.

## Danfoss pressure sensor kits

Content	Liquid temperature	Pressure [bar]	Product number
<ul style="list-style-type: none"> <li>Danfoss pressure transmitter, type MBS 3000, with 2 m screened cable. Connection: G 1/2 A (DIN 16288 - B6kt)</li> <li>5 cable clips (black)</li> <li>Instructions PT (400212)</li> </ul>	-40 to +85 °C	0-4	96428014
		0-6	96428015
		0-10	96428016
		0-16	96428017
		0-25	96428018

## DPI differential-pressure sensor kit

Content	Pressure [bar]	Product number
<ul style="list-style-type: none"> <li>1 sensor incl. 0.9 m screened cable (7/16" connections)</li> <li>1 original DPI bracket for wall mounting</li> <li>1 Grundfos bracket for mounting on motor</li> <li>2 M4 screws for mounting of sensor on bracket</li> <li>1 M6 screw (self-cutting) for mounting on MGE 90/100</li> <li>1 M8 screw (self-cutting) for mounting on MGE 112/132</li> <li>3 capillary tubes (short/long)</li> <li>2 fittings (1/4" - 7/16")</li> <li>5 cable clips (black)</li> <li>Installation and operating instructions (00480675)</li> <li>Service kit instructions.</li> </ul>	0 - 0.6	96611522
	0 - 1.0	96611523
	0 - 1.6	96611524
	0 - 2.5	96611525
	0 - 4.0	96611526
	0 - 6.0	96611527
	0-10	96611550

Adapter kit for sensor<sup>1)</sup>

Content	Type	Product number
Adapter for sensor	G 1/2 EPDM	99352712
	G 1/2 FKM	99352737

<sup>1)</sup> Applies to CRN 95.

## 9. Variants

The variants are available on request.

Although the Grundfos CR, CRI, CRN product range offers a number of pumps for different applications, customers require specific pump solutions to satisfy their needs. See the following documents:

- Grundfos "CR Custom-built pumps" data booklet
- Grundfos "CR, CRN high pressure" data booklet.

Below please find the range of options available for customising the CR pumps to meet the customers' demands.

Contact Grundfos for further information or for requests other than the ones mentioned below.

### Motors

Variant	Description
<b>ATEX-approved motor</b>	For operation in hazardous atmospheres, explosion-proof or dust-ignition-proof motors may be required.
<b>Motor with anti-condensation heating unit</b>	For operation in humid environments motors with built-in anti-condensation heating unit may be required.
<b>Motor with thermal protection</b>	We offer motors with built-in bimetallic thermal switches or temperature-controlled PTC sensors (thermistors) incorporated in the motor windings.
<b>Oversize motor</b>	Ambient temperatures above 40 °C or installation at altitudes of more than 1000 metres above sea level require the use of an oversize motor (that is derating).
<b>4-pole motor</b>	We offer 4-pole standard motors.

### Shaft seals

Variant	Description
<b>Shaft seal with FFKM O-ring</b>	We recommend shaft seals with FFKM or FXM O-ring for applications where the pumped liquid may damage the standard O-ring material.
<b>Seal with flush, quench seal</b>	We recommend this for applications involving crystallising, hardening or sticky liquids.
<b>Air-cooled shaft seal system</b>	We recommend this for applications involving extremely high temperatures. No conventional mechanical shaft seal can withstand liquid temperatures of up to 180 °C for any length of time. For such applications, we recommend Grundfos' unique air-cooled shaft seal system. In order to ensure a low liquid temperature around the standard shaft seal, the pump is fitted with a special air-cooled shaft seal chamber. No separate cooling is required.
<b>Double seal with pressure chamber</b>	We recommend this for applications involving poisonous or explosive liquids. It protects the surrounding environment and the people working in the vicinity of the pump. It consists of two seals mounted in a "back-to-back" arrangement inside a separate pressure seal chamber. As the pressure in the chamber is higher than the pump pressure, leakage is prevented. A dosing pump or a special pressure intensifier generates the seal chamber pressure.
<b>CR MAGdrive</b>	Magnetically driven pumps for industrial applications. Key applications are industrial processes involving the handling of aggressive, environmental, dangerous or volatile liquids, such as organic compounds and solvents.

### Pumps

Variant	Description
<b>Horizontally mounted pump</b>	For safety or height reasons, certain applications, for instance on ships, require the pump to be mounted in horizontal position. For easy installation, the pump is fitted with brackets that support motor and pump.
<b>Low-temperature pump</b>	Exposed to temperatures down to -40 °C, coolant pumps may require neck rings with a different diameter in order to prevent impeller drag.
<b>High-pressure pump up to 47 bar</b>	For high-pressure applications, we offer a unique double pump system capable of generating a pressure of up to 47 bar.
<b>Low-NPSH pump (improved suction)</b>	We recommend this for boiler-feed applications where cavitation may occur due to poor inlet conditions.
<b>Pump with bearing flange</b>	The bearing flange is suitable for applications where the inlet pressure is higher than the maximum pressure recommended. The bearing flange increases the life of motor bearings. We recommend this for standard motors.
<b>Belt-driven pump</b>	Belt-driven pumps are designed to operate in places with limited space or where no electrical power is available.
<b>Pump for pharmaceutical and biotechnological applications</b>	CRN pumps are designed for applications requiring the sterilisation and CIP capability of pipes, valves and pumps. (CIP = clean-in-place.)

### Connections and other variants

Variant	Description
<b>Pipe connections</b>	In addition to the wide range of standard flange connections, a 16-bar DIN standard clamping flange is available. Customised flanges are available according to specifications.
<b>TriClamp connection</b>	TriClamp connections are of a hygienic design with a sanitary coupling for use in the pharmaceutical and food industry.
<b>Electropolished pump</b>	To substantially reduce the risk of corrosion of the materials, we offer electropolished pumps. We recommend this for applications in the pharmaceutical and food industry.

## 10. Grundfos Product Center

Online search and sizing tool to help you make the right choice.

<http://product-selection.grundfos.com>

### All the information you need in one place

Performance curves, technical specifications, pictures, dimensional drawings, motor curves, wiring diagrams, spare parts, service kits, 3D drawings, documents, system parts. The Product Center displays any recent and saved items - including complete projects - right on the main page.

### Downloads

On the product pages, you can download installation and operating instructions, data booklets, service instructions, etc. in PDF format.



TM07 2384

TM07 2383

### Pos. Description

- |   |   |
|---|---|
| 1 | This drop-down menu enables you to set the search function to "Products" or "Literature".   |
| 2 | <b>SIZING</b> enables you to size a pump based on entered data and selection choices.   |
| 3 | <b>CATALOGUE</b> gives you access to the Grundfos product catalogue.<br><b>REPLACEMENT</b> enables you to find a replacement product.<br>Search results will include information on |
| 4 | the lowest purchase price<br>the lowest energy consumption<br>the lowest total life cycle cost.   |
| 5 | <b>LIQUIDS</b> enables you to find pumps designed for aggressive, flammable or other special liquids.   |

99301179 02.2021

ECM: 1307864

**GRUNDFOS A/S**  
DK-8850 Bjerringbro . Denmark  
Telephone: +45 87 50 14 00  
[www.grundfos.com](http://www.grundfos.com)

**GRUNDFOS** 