

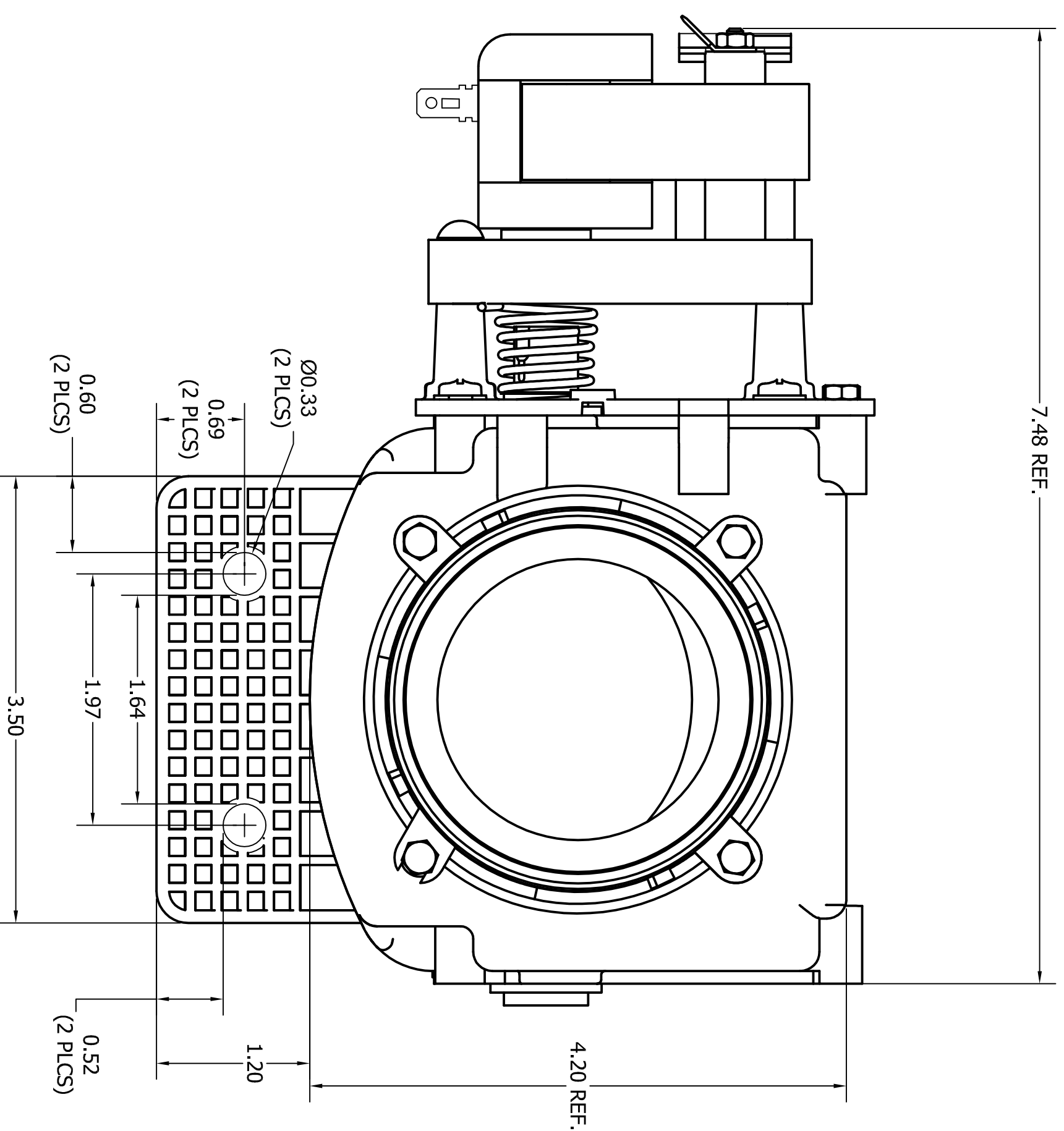

REVISION HISTORY			
REV	DESCRIPTION	DATE	APPROVED
	RELEASED	3/18/14	CD
A	ECN-D1041 CHG MOTOR DESCRIP FROM SLASHES TO DASHES	12/04/15	WH
B	ECN-D1060: REMOVED CSA FROM NOTE #3. (DT)	2/23/16	WH

- NOTES:
 1) HOUSING MATERIAL = POLYPROPYLENE
 2) COLOR = BLACK
 3) VALVES ARE A UL RECOGNIZED COMPONENT, FOR BOTH U.S. AND CANADA.

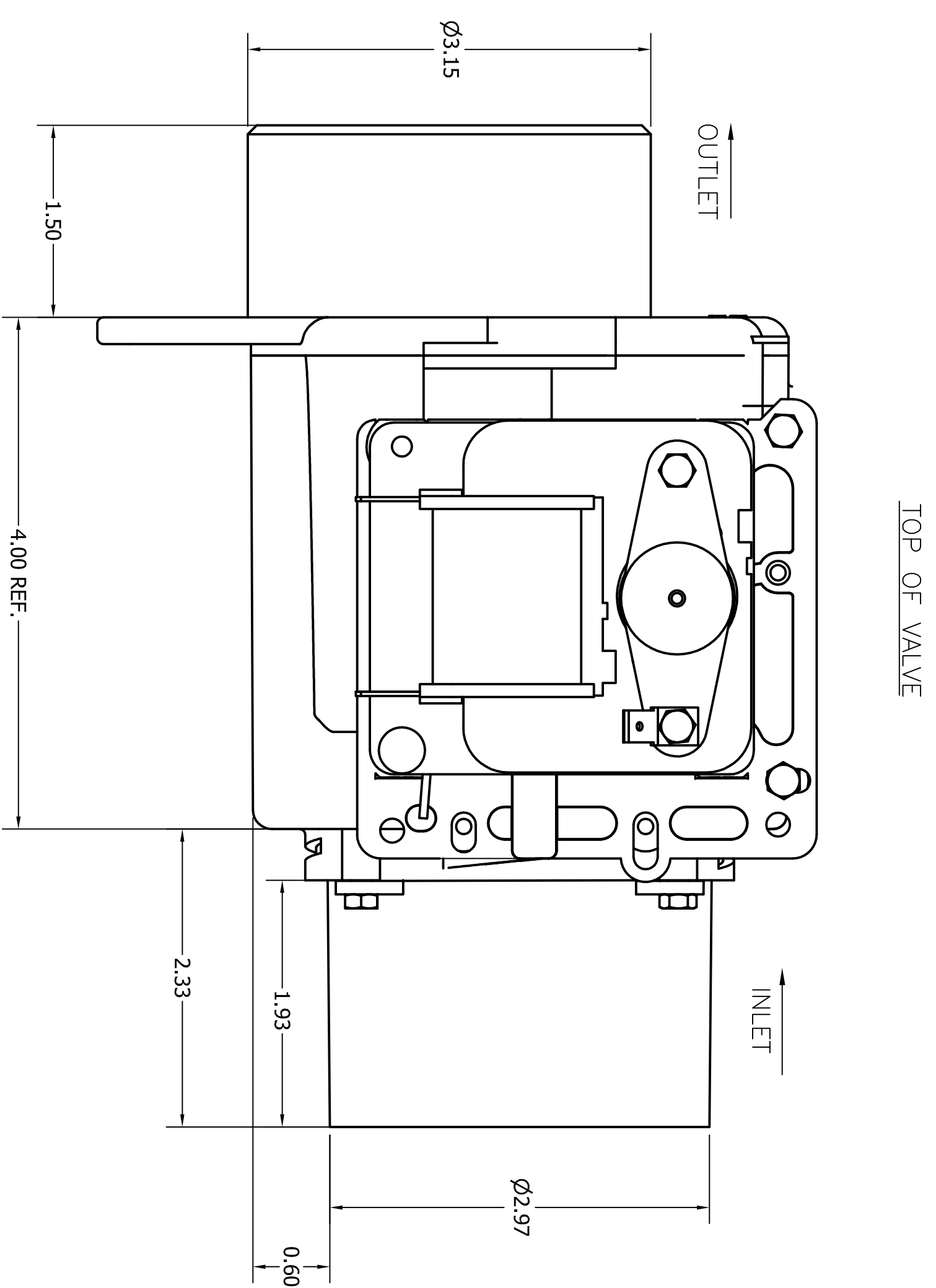

DOD PART NUMBER MOTOR RATING N.O./N.C.

33011621 230 V, 50-60 HZ, 0.20-.17 AMP, 2 TERMINAL N.O.

DRAWN	DZ	3/10/14	 Depend-O-Drain, Inc. Bradenton, FL 34202 Tel.: (941) 756-1710 Fax: (941) 758-9178 E-mail: info@dependodrain.com	MDB-O-3 NORMALLY OPEN BALL VALVE	SIZE	DWG NO	REV
CHECKED					C	330121	B
QA							
MFG							
APPROVED							
SCALE 1:1			SHEET 1 OF 1				