

Einlegen der Rolle / Roll feeding / Chargement de bobine / Poner el rollo

**Rollen mit geringerer Breite dürfen nicht eingesetzt werden.**

Rolls with smaller width cannot be used.

Ne pas monter des rouleaux avec moins de largeur.

No se deben montar rollos con una anchura más pequeña.

**C = Länge Abreißschiene**

C = length of cutter bar

C = longueur de la barre

C = longitud de la barra

**Rollengewicht max. 20 kg**

Roll weight max. 20 kg

Poids max. du rouleau 20 kg

Peso máx. de rollo 20 kg

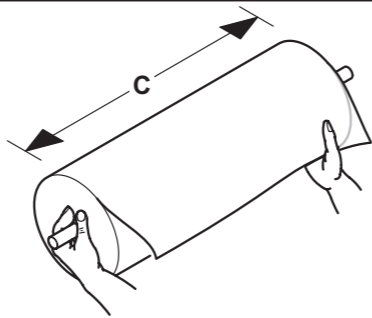

**Abrollrichtung des Materials beachten!**

Pay attention to the direction the materials rolls off!

Tenir compte du sens de déroulement!

Observar la dirección del desarrollo del material!

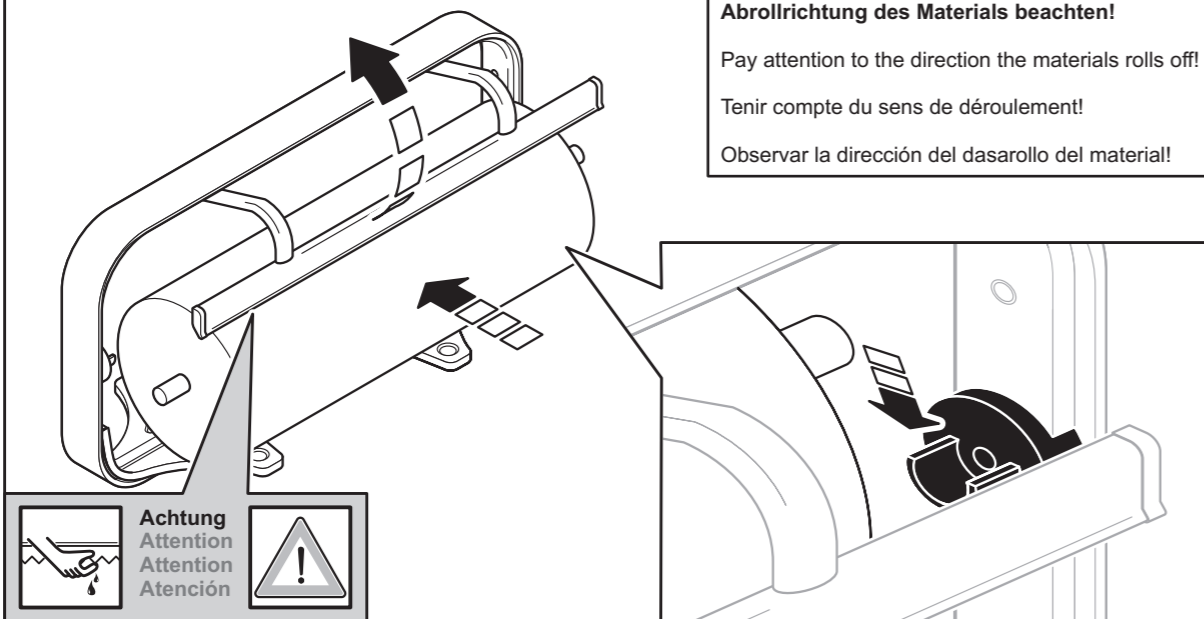

Ersatzteile: / Spare parts / Pièces de rechange / Piezas de recambio

- a** Abreißmesser, glatt oder gezahnt, mit Bügel: Länge angeben
- b** Rollenachse: Rollenbreite angeben
- c** Abreißmesser: Rollenbreite angeben

- a** Tear bar smooth or serrated with holder: indicate length
- b** rod: indicate width of roll
- c** smooth blade: indicate width of roll

- a** Barre de coupe lisse ou dentelée avec support: indiquer longueur
- b** axe: indiquer largeur de bobine
- c** barre lisse: indiquer largeur de bobine

- a** Barra de cortar liso o dentada con soporte: indique longitud
- b** Eje: Indique la anchura del rollo
- c** Barra de corta: Indique la anchura del rollo

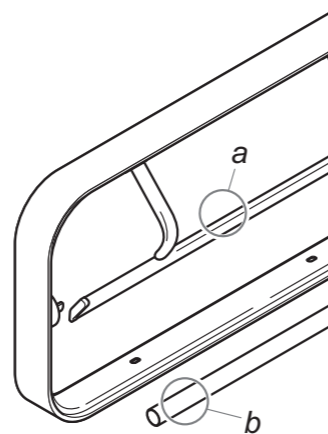

**Gebrauchsanleitung**  
**Instructions for use**  
**Mode d'emploi**  
**Modo de empleo**

**STANDARD**

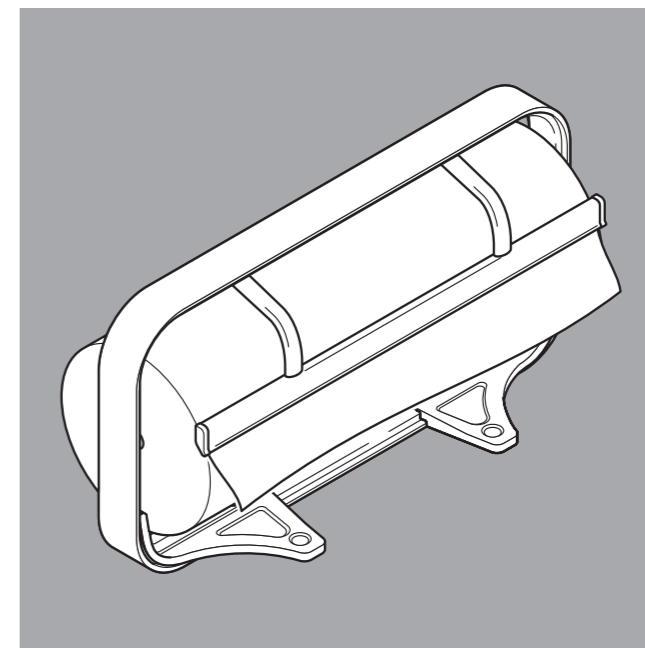

**Abroller**  
**Dispensers**  
**Dérouleurs**  
**Portarollos**

06/11 93090031





Achtung  
Attention  
Attention  
Atención



Verletzungsgefahr  
Danger of injury  
Danger de blessure  
Peligro de lesión

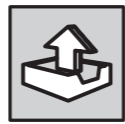

Lieferumfang  
Contents  
Contenu  
Contenido



Montageanleitung  
Mounting instructions  
Instructions de montage  
Instrucciones de montaje

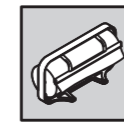

Gebrauchsanleitung  
Instructions for use  
Mode d'emploi  
Modo de empleo

**STANDARD 151...** Tischabroller / Table dispenser / Dérouleur de table / Portarollo de mesa

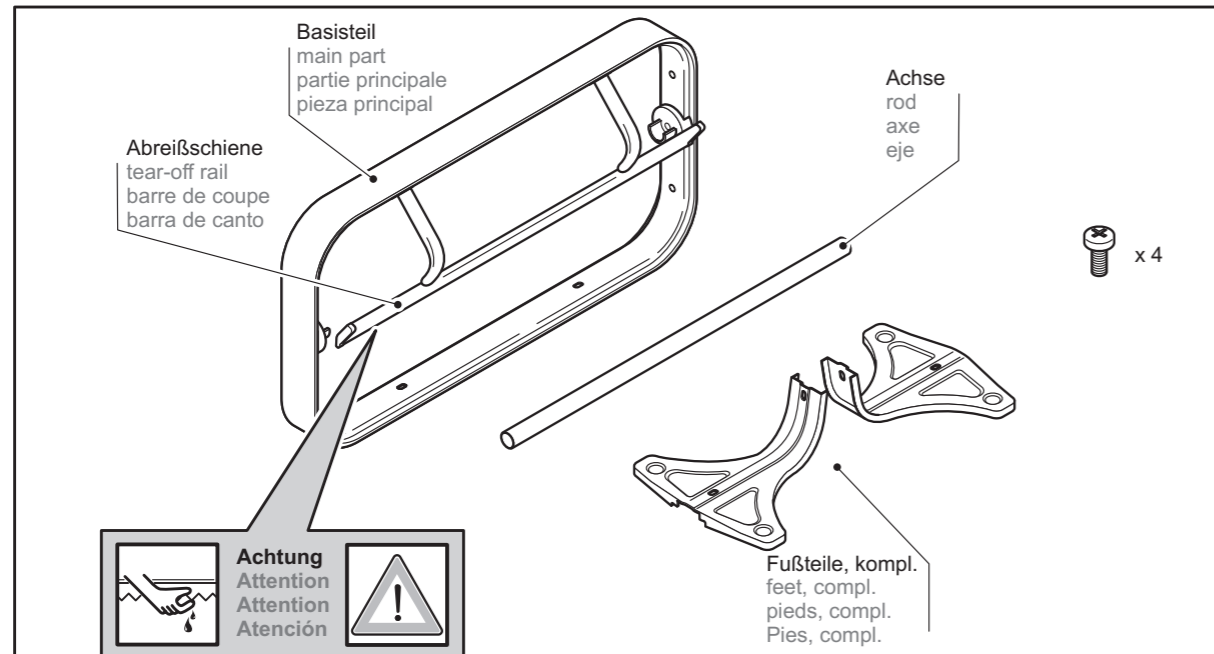
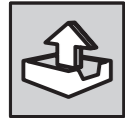

**STANDARD 152...** Wandabroller / Wall dispenser / Dérouleur mural / Portarollo mural

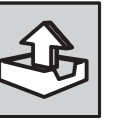
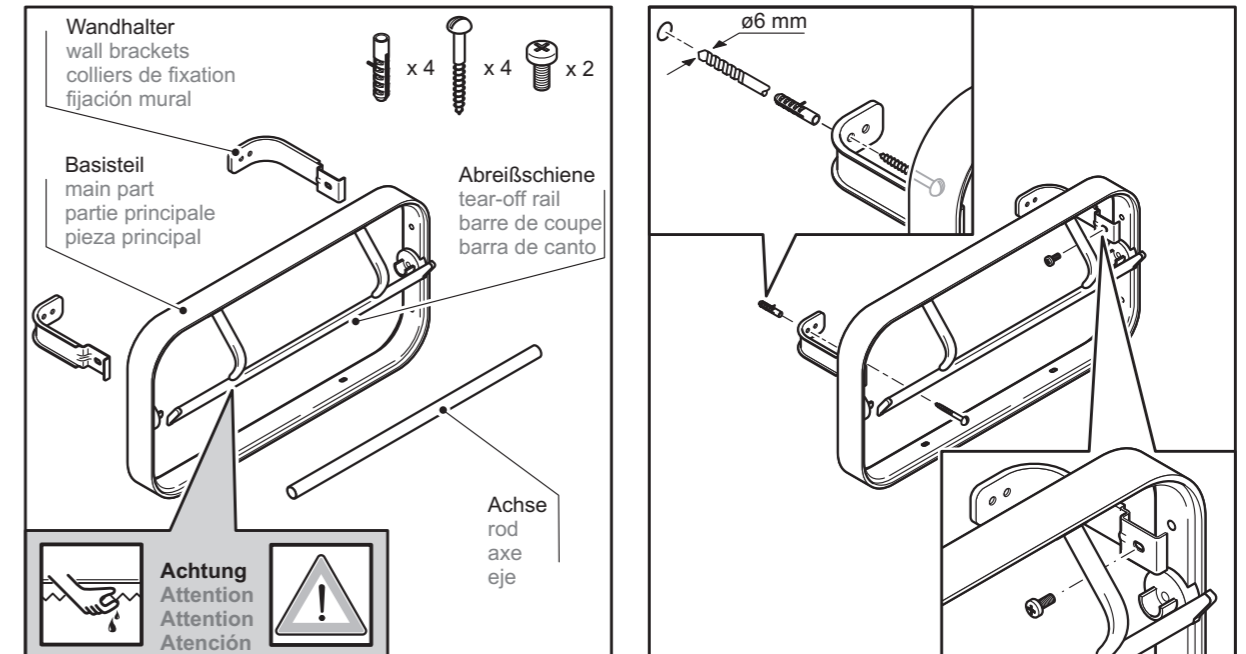

Tischabroller / Table dispenser / Dérouleur de table / Portarollo de mesa

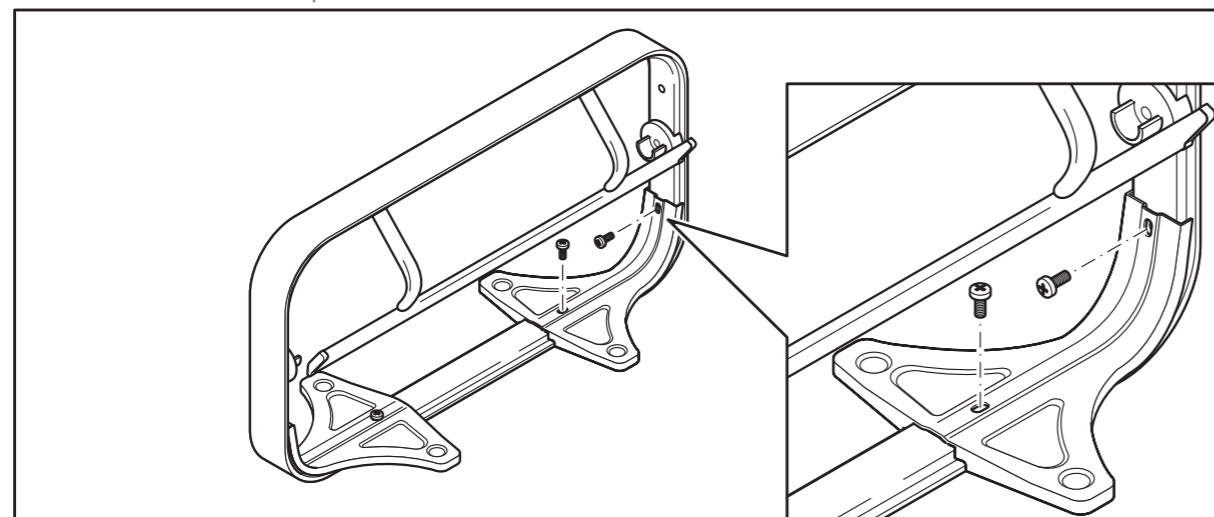

**STANDARD 154...** Aufsatz-Abroller / Dispenser attachment / Dérouleur superposable / Portarollo acople

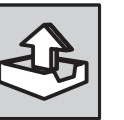
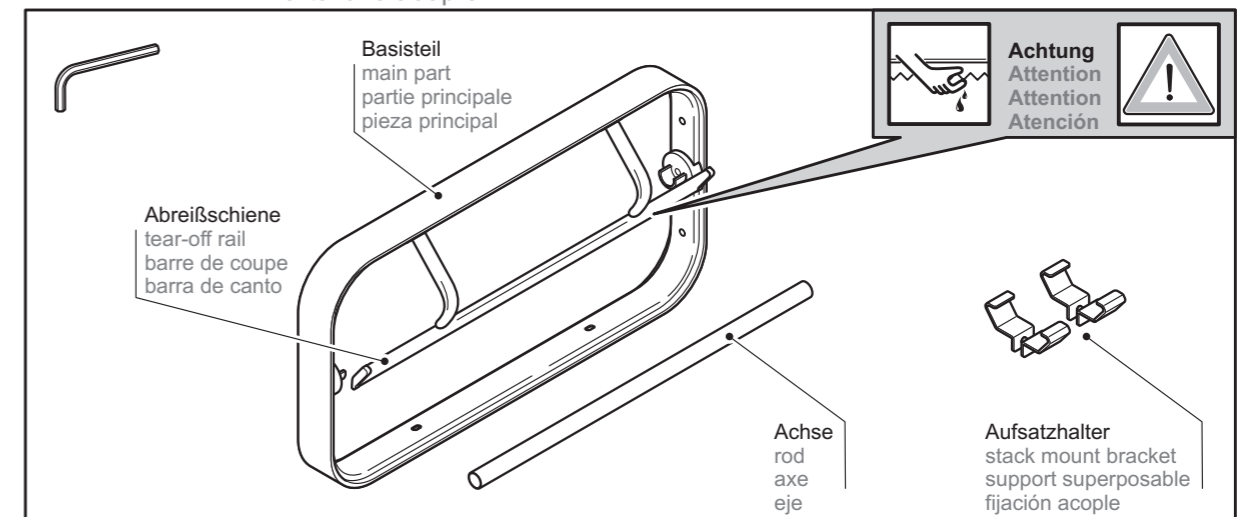

**STANDARD 180...** Untertisch-Abroller / Under-table dispenser / Dérouleur sous table / Portarollo debajo de mesa

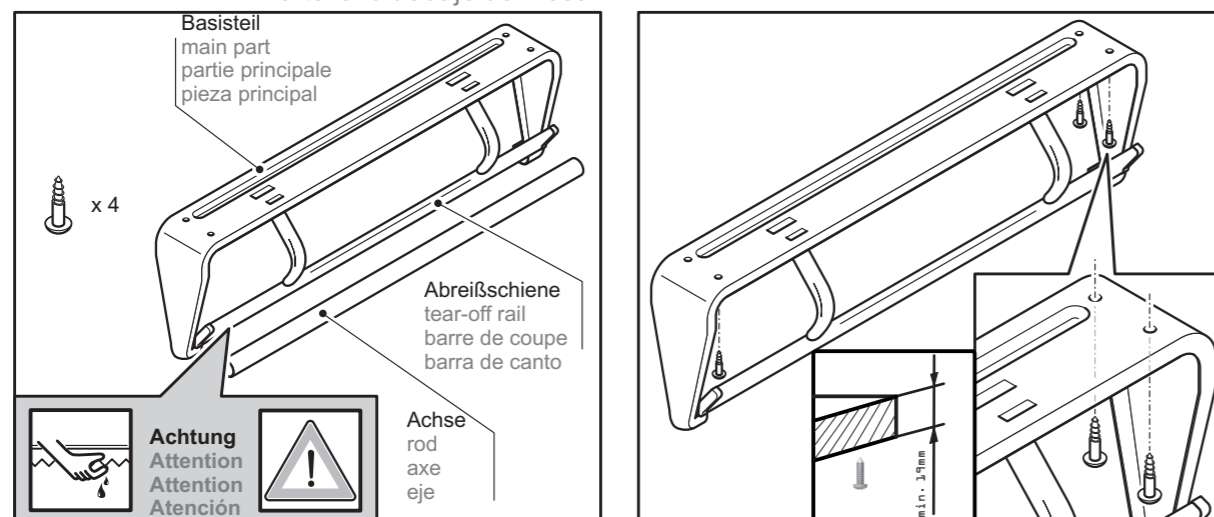
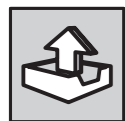

Aufsatz-Abroller / Dispenser attachment / Dérouleur superposable / Portarollo acople

